

Service Manual

COMPACT
disc
DIGITAL AUDIO

DIGITAL

Portable CD Player

SL-XP505

Color

(K)... Black Type



Area

Country Code	Area	Color
(EB)	Great Britain.	(K)
(EG)	F.R. Germany & Italy.	
(GC)	Asia, Latin America, Middle Near East and Africa.	
(GN)	Oceania.	

SL-XP6 MECHANISM SERIES (S0DD100Z)

■ SPECIFICATIONS

- **Audio**
- No. of channels:** 2 channels (stereo)
Frequency response: 20–20000Hz
 (+0.5dB, –1.5dB)
Output voltage: 1.0V (50kΩ) mini jack φ3.5
Dynamic range: more than 94dB
S/N ratio: more than 96dB
Wow and flutter: Below measurable limit
Digital filter: 18 bit, 8 times oversampling
DA converter: 16 bit, 2 DAC
Headphone output level: max. 15mW/16Ω (adjustable)
 mini jack φ3.5
- **Signal Format**
- Correction system:** Technics New Super Decoding Algorithm
- **Pickup**
- Light source:** Semiconductor laser
Wavelength: 780nm
Lens: Glass pressed lens
- **General**
- Power requirement:** AC; with an included AC adaptor (RFEA401B-W (EB), RFEA401E-1S (EG), RFEA402Z-W (GC), RFEA401A-W (GN))
 Battery; with optional two "AA" size (LR6/R6) batteries (DC 1.5V × 2)
 Rechargeable Battery; with an included rechargeable batteries (SH-CDB8-3: DC 1.2V × 2)
- DC IN:** 4.5V
- Power consumption:**
AC adaptor; 3W
Battery; 0.8W (DC 3V)
Dimensions (W × H × D): 128 × 29.7 × 148mm
 (5" × 1-1/8" × 5-11/16")
Weight: 345g with batteries
- **Remote control transmitter**
- Dimensions (W × H × D):** 65 × 19 × 77.5mm
Weight: 60g (including battery)
Battery: UM-4, "AAA" (R03) 1.5V × 2
- **Remote sensor**
- Dimensions (W × H × D):** 31.3 × 15 × 29.3mm (including plug)
 16.3 × 15 × 29.3mm (without plug)
Weight: 6.2g
- Note:**
 Specifications are subject to change without notice.
 Weight and dimensions are approximate.

Technics

CONTENTS

	Page		Page
PANEL CONTROLS.....	2	TEST POINTS AND ADJUSTMENT POINTS.....	16
PRECAUTION OF LASER DIODE.....	3	ADJUSTMENT PROCEDURE.....	17~19
BEFORE USE.....	4	BLOCK DIAGRAM.....	19~22
CONNECTIONS.....	4	PRINTED CIRCUIT BOARD AND WIRING	
POWER SOURCE.....	5	CONNECTION DIAGRAM.....	23~24
REMOTE CONTROL TRANSMITTER.....	6	SCHEMATIC DIAGRAM.....	25~30
HANDLING PRECAUTION FOR TRAVERSE DECK.....	7	TERMINAL GUIDE OF IC'S,	
DISASSEMBLY INSTRUCTIONS.....	8~10	TRANSISTORS AND DIODES.....	25
HOW TO CHECK THE MAIN P.C.B.....	11	TERMINAL FUNCTION OF IC'S.....	31~35
CHECKING THE OPERATION PROBLEMS ON THE		INTERNAL CONNECTIONS OF LCD.....	35
TRAVERSE DECK (OPTICAL PICKUP).....	12~13	EXPLODED VIEW.....	36
NOTE FOR SERVICE.....	13	REPLACEMENT PARTS LIST.....	37~40
MEASUREMENTS AND ADJUSTMENTS.....	14~15	PACKING.....	40

PANEL CONTROLS

Main unit

The functions indicated by the numbers (①-④) can also be activated using the remote control transmitter.

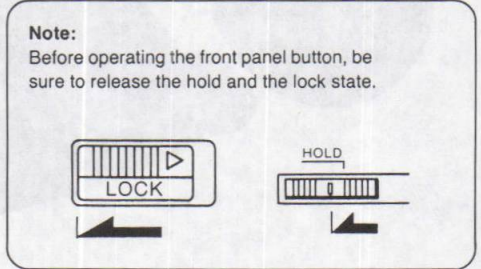
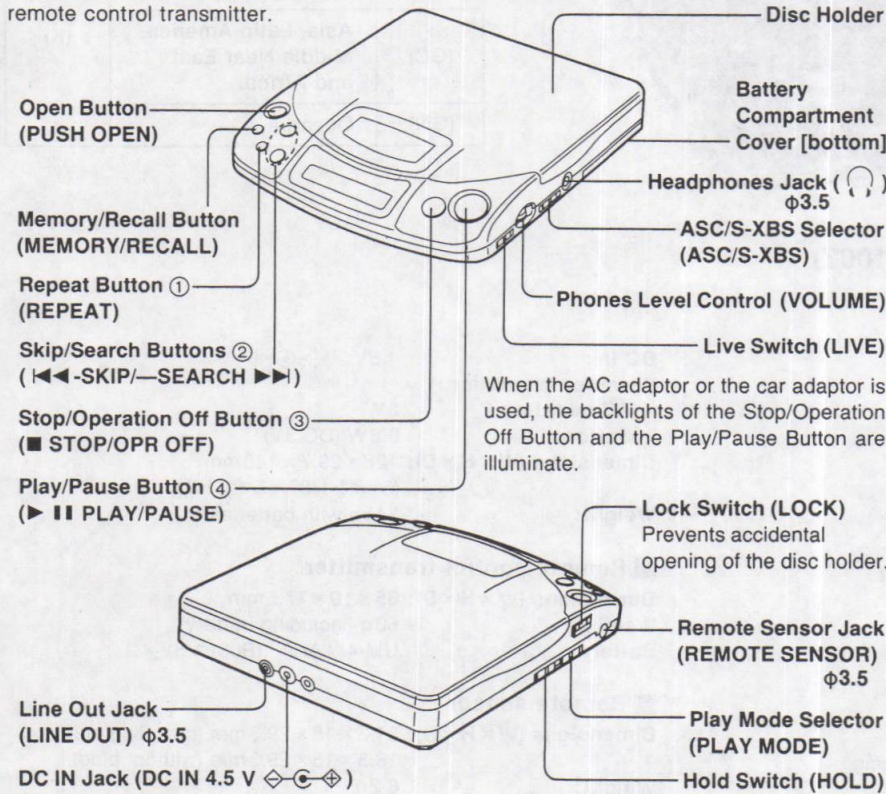

Connect the included Remote Control Receiver Unit to Remote Sensor Jack. The included Remote Control Transmitter is designed only for this unit. Use the included AC Adaptor or optional car adaptor.

Notes:

- The remote control signal is non-directional when using the unit in the car.
- When using the unit with the batteries (dry cell or rechargeable), be sure to set the main unit to the stop mode (number of tracks and the total playing time are displayed) before operating from the remote control.

Preparation

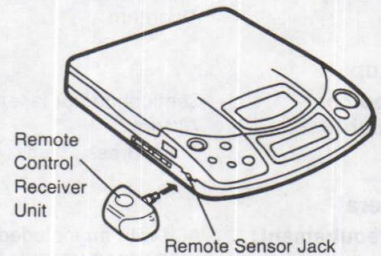

Display

If this unit is used by AC adaptor or Car adaptor, the backlight of the display will be turned on.

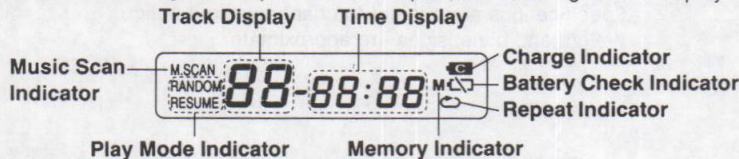

Remote Control Transmitter

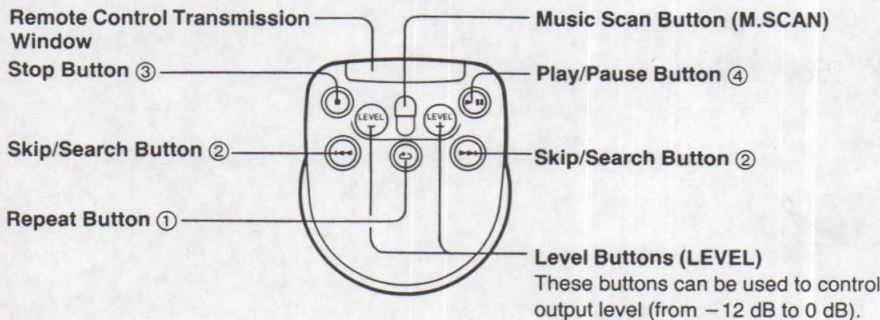

Service Manual

Portable CD Player

SL-XP505

Supplement



Colour

(K) ... Black Type

Area

Suffix for Model No.	Area	Colour
(EB)	Great Britain.	(K)
(EG)	Germany & Italy/ Europe.	
(GC)	Asia, Latin America, Middle Near East and Africa.	
(GN)	Oceania.	

Please file and use this supplement manual together with the service manual for Model No. SL-XP505, Order No. AD9111283C8.

Note: • This supplement is intended to provide additional information or corrections to the existing service manual for model No. SL-XP505. Be sure to update your service manual for future reference.

• This supplement is issued to inform you that the Cabinet and Chassis parts are changed in units having serial number suffixes "A" and "B".
(Refer to "How to read the serial number" shown at right.)

• How to read the serial number

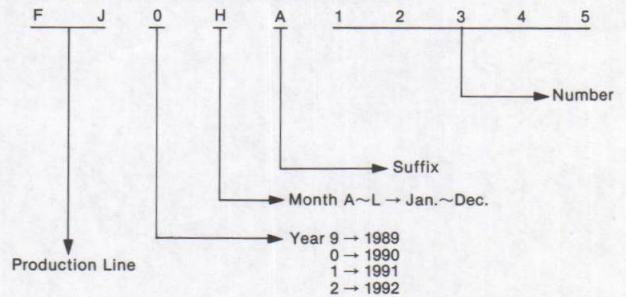

ADDITION

REPLACEMENT PARTS LIST (on page 37.)

Ref. No.	Change of Part No.		Part Name & Description	Remarks
	ORIGINAL	NEW		
CABINET AND CHASSIS				
39	—	RMX0067	SHEET	

EXPLODED VIEWS (on page 36.)

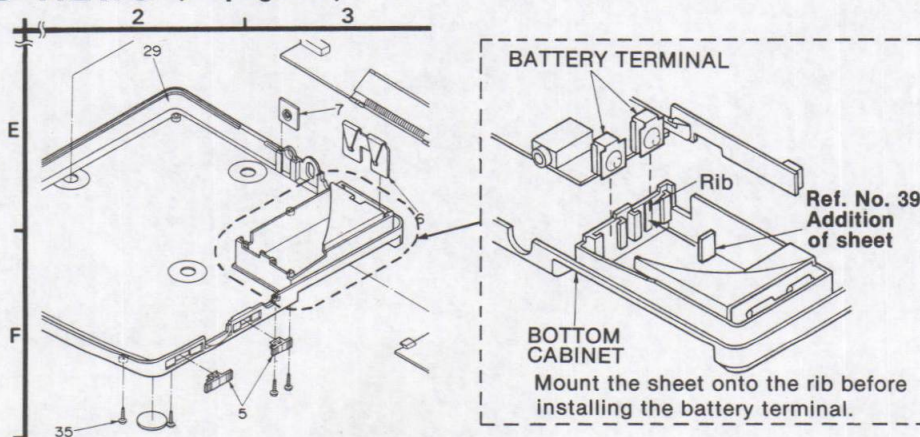

Technics

PRECAUTION OF LASER DIODE

CAUTION: This product utilizes a laser diode with the unit turned "on", invisible laser radiation is emitted from the pick up lens.
Wave length: 780nm
Maximum output radiation power from pick up: 100µW/VDE

Laser radiation from the pick up lens is safety level, but be sure the followings:

1. Do not disassemble the optical pick up unit, since radiation from exposed laser diode is dangerous.
2. Do not adjust the variable resistor on the pickup unit. It was already adjusted.
3. Do not look at the focus lens using optical instruments.
4. Recommend not to look at pick up lens for a long time.

ACHTUNG: Dieses produkt enthält eine laserdioden. Im eingeschalteten zustand wird unsichtbare laserstrahlung von der lasereinheit abgestrahlt.

Wellenlänge: 780nm
Maximale strahlungsleistung der lasereinheit: 100µW/VDE

Die strahlung an der lasereinheit ist ungefährlich, wenn folgende punkte beachtet werden:

1. Die lasereinheit nicht zerlegen, da die strahlung an der freigelegten laserdioden gefährlich ist.
2. Den werksseitig justierten einstellregler der lasereinheit nicht verstellen.
3. Nicht mit optischen instrumenten in die fokussierlinse blicken.
4. Nicht über längere zeit in die fokussierlinse blicken.

ADVARSEL: I dette a apparat anvendes laser.

• Use of caution labels

Note: ○ Mark is used, × Mark is not used.

Areas	SQWD7	RQLS0024	RQLS0051
(E G)	○	○	○
Others	○	○	×

SQWD7



RQLS0024



RQLS0051

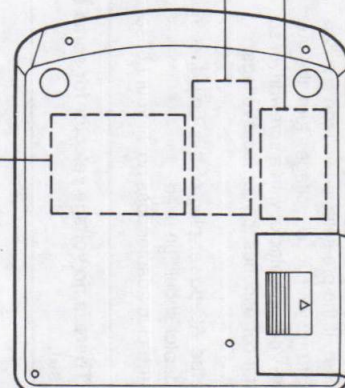

BEFORE USE

Make sure the AC Line-Voltage Selector of your AC adaptor is matched to your local voltage before plugging it into the AC socket. If the pre-selected voltage is different from your local voltage, turn the AC Line-Voltage Selector with a screwdriver so that it corresponds to your local voltage.

- If the AC power plug of this unit does not fit your ordinary household AC outlet, a plug adaptor should be used.
- If the plug adaptor does not fit your household AC outlet, consult with your dealer.

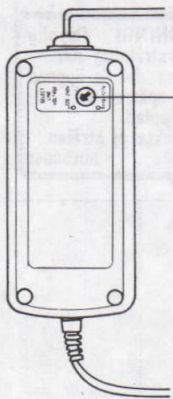

AC Line-Voltage Selector

There is no voltage selector for some countries; the correct voltage is already set.

ACCESSORIES

Remote Control Transmitter 1 pc. (EURSBFA06NT)



Remote Control Receiver Unit . . . 1 pc. (RCDNTR1008A)



AC Adaptor 1 pc.
 (RFEA401E-IS): (EG)
 (RFEA401B-W): (EB)
 (RFEA402Z-W): (GC)
 (RFEA401A-W): (GN)



Stereo Connection Cable 2 pcs. (SJPDS-2K)



Stereo Earphones (with remote controller) (RFEV102A-K2S)



Rechargeable Batteries 2 pcs. (SH-CDB8-3): (EG), (EB)
 (SH-CDB8-2): (GC), (GN)



Batteries UM-4, "AAA" (R03) . . . 2 pcs. (for Remote Control Transmitter)



CONNECTIONS

Listening through an audio system

Use the Stereo Connection Cable (included) to connect this unit to a receiver or a stereo cassette recorder.

- Switch OFF the power to the receiver or stereo radio cassette recorder before connecting this unit.
- Do not connect this unit to the PHONO terminals of the receiver or stereo radio cassette recorder.

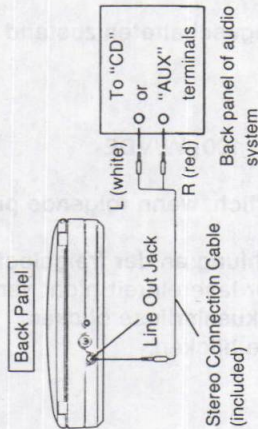

Listening through the stereo earphones or headphones

Connect the plug of the Stereo Earphones (included) or headphones (option) to the Headphones Jack.

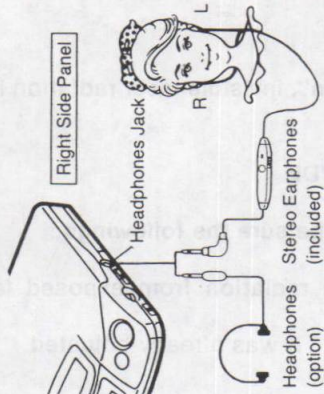

Note for stereo earphones:

The right earphone cord is longer than the left and is adjustable for your convenience.

Precautions for Listening with the Headphones

- Do not play your headset at a high volume. Hearing experts advise against continuous extended play.
- If you experience a ringing in your ears, reduce volume or discontinue use.
- Do not use while operating a motorized vehicle. It may create a traffic hazard and is illegal in many areas.
- You should use extreme caution or temporarily discontinue use in potentially hazardous situations.
- Even if your headset is an open-air type designed to let you hear outside sounds, don't turn up the volume so high that you can't hear what's around you.

Note: The configuration of the AC outlet and AC power supply cord differs according to the area.

POWER SOURCE

This unit may be used with the included rechargeable batteries, the optional two LR6 type alkaline batteries, the included AC Adaptor or the optional Car Adaptor (SH-CDC9, optional).

Rechargeable batteries operation

For its initial use after purchasing or after a long time interval (more than three months), make sure to recharge the rechargeable batteries. Normally 1 hour recharging will give approximately 1.5 hours and 3 hours recharging will give approximately 2.5 hours play.

1. Open the battery compartment cover and insert the rechargeable batteries into the battery compartment, making sure that the proper polarities are maintained.

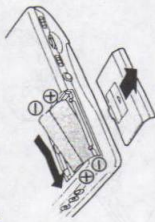

2. Close the cover and connect the AC Adaptor as shown in the figure.

• The Charge Indicator will begin flashing. When the indicator lights, playing for approximately 1.5 hours can be operated. The indicator will turn off, when the charging is finished.

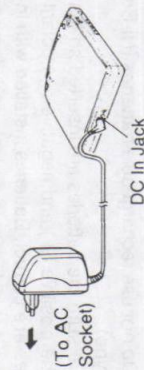

The shapes of the AC adaptor and plug may differ according to the area.

Optional LR6 type battery operation

Two LR6 type alkaline batteries can be inserted into the battery compartment in the same way as the rechargeable batteries.

- Battery condition can be also checked by the Battery Check Indicator. The indicator begins flashing on and off at a half consumption of the battery life. Use of alkaline batteries will give approximately 3.5 hours play.

Notes:

- Batteries installed with incorrect polarities may leak and damage this unit.
- Do not mix batteries (old and new) or types (Ni-Cd, alkaline and carbon).
- If the set is not used for a long period of time or is used only from an AC power source, remove all the batteries for battery life and to prevent potential damage due to possible battery leakage.

AC power operation

Use only the included AC Adaptor with this unit.

1. Insert the plug, at the end of the AC Adaptor cord, into the DC In Jack.
2. Plug the AC Adaptor into your household AC power outlet.

CAUTION:

Do not use the included AC Adaptor for other products.

Note:

To operate on battery power, unplug the AC Adaptor from the household AC Power Outlet and the DC In Jack on the unit.

Car battery operation

Follow the operating instructions of the optional Car Adaptor.

The rechargeable battery can be recharged with the Car Adaptor.

Please purchase the optional car mounting kit (SH-CDF7) and the car stereo cassette adaptor (SH-CDM7) before using this unit in a car.

CAUTION:

Use only car adaptor, Model: SH-CDC9, manufactured by Matsushita Electric Industrial Co., Ltd.

Notes:

- The batteries supplied with this unit are designed for Technics brand portable audio products only. Use in other products could cause damage or personal injury.
- Use only the included AC Adaptor or optional Car Adaptor when recharging.
- During recharging, the AC Adaptor and rechargeable batteries may get warm. This is normal.
- On its initial use after purchasing or its use after a long time interval, 3 hours recharging may not provide normal operation time. But the repeat of recharging will recover the normal operation time.
- Avoid recharging or placing the rechargeable battery near sources of heat or humidity. Recharging should be performed at 0°C~40°C (32°F~104°F).
- Do not attempt to recharge LR6/R6 type alkaline or carbon batteries.
- Do not use a rechargeable battery mixed with the other type (carbon or alkaline).
- Do not allow metal objects to touch the terminals. (A hazardous short circuit may result.)
- Do not incinerate the battery or bring it near a fire or open flame.
- If a battery leak should occur and the electrolyte comes into contact with skin or clothes, flush with water immediately. If the internal parts of the battery become visible because of damage to the battery, discard it immediately.

REMOTE CONTROL TRANSMITTER

Battery installation

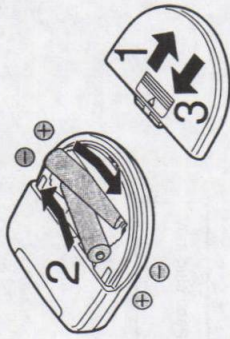

- Do not use rechargeable batteries (Ni-Cd type).
- Be sure the batteries are inserted so that the positive (+) and negative (-) polarities are correct. Batteries installed with incorrect polarities may leak and damage the remote control transmitter.
- Never subject the batteries to excessive heat or flame; do not attempt to disassemble them; and be sure they are not short-circuited.
- If the remote control transmitter is not to be used for a long time, remove the batteries and store them in a cool dark place.
- Remove old, weak or worn-out batteries promptly and dispose of them.
- Never mix old and new batteries, nor batteries of different types (carbon or alkaline).

Operation notes



Aim the remote control transmission window toward the unit's sensor. Avoid any obstacles.



Use the remote control within a 60 degree angle and within 6 meters (20 ft.) from the unit.

This unit

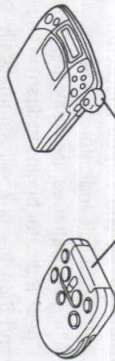

Avoid dust.

Be sure the transmission window and the unit's sensor are free from dust. Excessive dust might prevent reception.

The operation may not be correct if direct sunlight or other strong light sources strike the remote control signal sensor part of this unit. If there is a problem, place the unit away from the light source.

STEREO EARPHONES

The following operation can be performed with the included Stereo Earphones, without pressing the operation buttons on the unit.

- play
- stop
- operation off
- skip
- volume control (phones level)

Connection

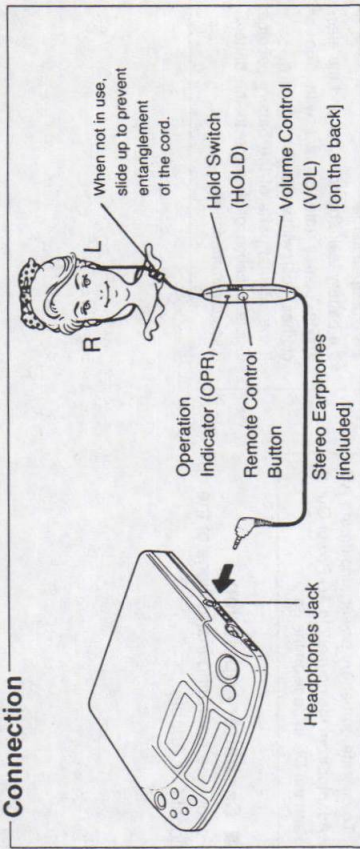

Operation

Before performing the remote control operation, be sure to release the hold state by sliding the Hold switch up.

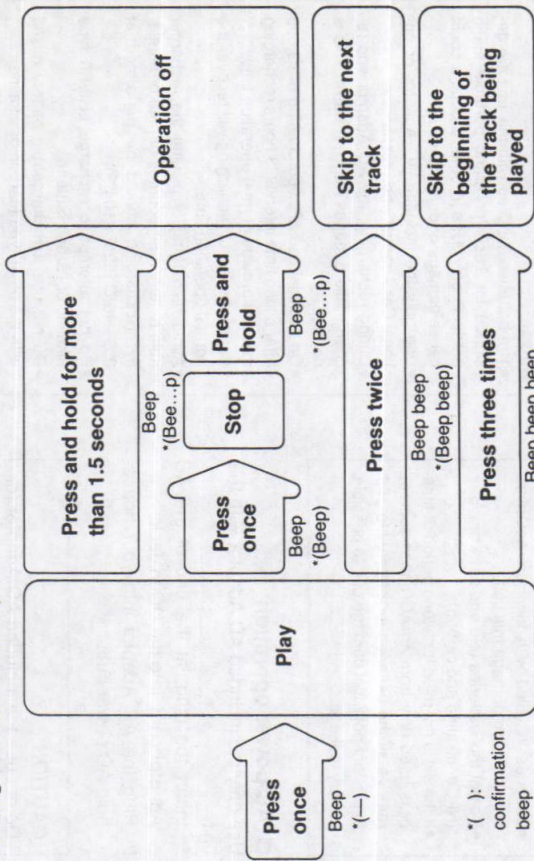

• The beep will be emitted each time the Remote Control Button is pressed.

Also, confirmation beeps will be emitted after pressed to confirm the proper operation.

• When pressing the button twice or three times in succession, press it within one second and at equal intervals.

• Volume can be controlled with the phones level control of the main unit. Make sure to adjust the phones level control of the unit to 5-7 position.

• The Operation Indicator lights during playing and flashes in the stop mode. (The indicator is turned off in a power off condition.)

Hold switch

If setting the hold state by sliding down the Hold switch, the Remote control button can not be pressed. This prevents the Remote control button is pressed by mistake.

HANDLING PRECAUTIONS FOR TRAVERSE DECK

The laser diode in the traverse deck (optical pickup) may break down due to potential difference caused by static electricity of clothes or human body.

So, be careful of electrostatic breakdown during repair of the traverse deck (optical pickup).

● Handling of traverse deck (optical pickup)

1. Do not subject the traverse deck (optical pickup) to static electricity as it is extremely sensitive to electrical shock.

2. To prevent the breakdown of the laser diode, an anti-static shorting pin is inserted into the flexible board (FPC board).

When removing or connecting the short pin, finish the job in as short time as possible.

3. Take care not to apply excessive stress to the flexible board (FPC board).

4. Do not turn the variable resistor (laser power adjustment). It has already been adjusted.

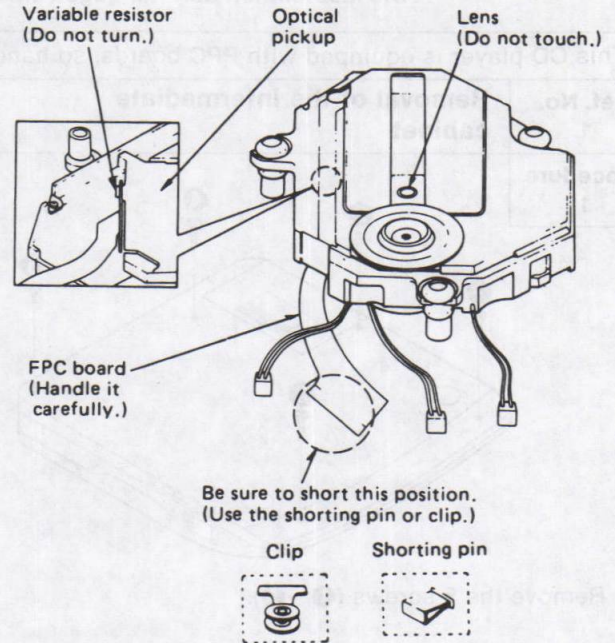

● Grounding for electrostatic breakdown prevention

1. Human body grounding.

Use the anti-static wrist strap to discharge the static electricity from your body.

2. Work table grounding

Put a conductive material (sheet) or steel sheet on the area where the traverse deck (optical pickup) is placed, and ground the sheet.

Caution:

The static electricity of your clothes will not be grounded through the wrist strap. So, take care not to let your clothes touch the traverse deck (optical pickup).

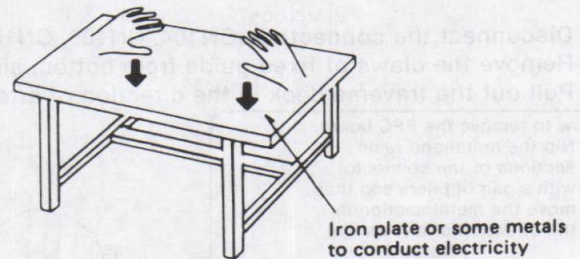
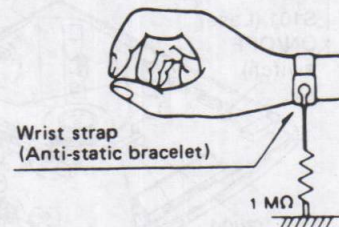

DISASSEMBLY INSTRUCTIONS

Warning: This product uses a laser diode. Refer to caution statements on page 3.

ACHTUNG: • Die lasereinheit nicht zerlegen.
• Die lasereinheit darf nur gegen eine vom hersteller spezifizierte einheit ausgetauscht werden.

※ This CD player is equipped with FPC boards, so handle them with care during disassembly and reassembly.

Ref. No. 1 **Removal of the intermediate cabinet**

Procedure 1

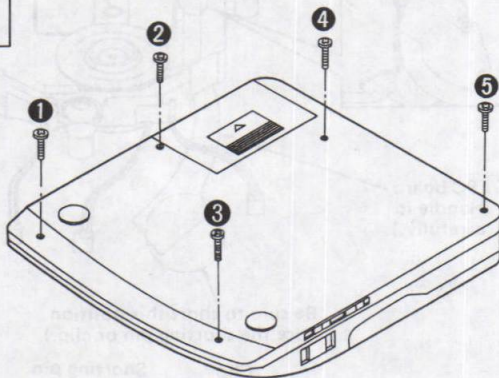

1. Remove the 5 screws (①~⑤).

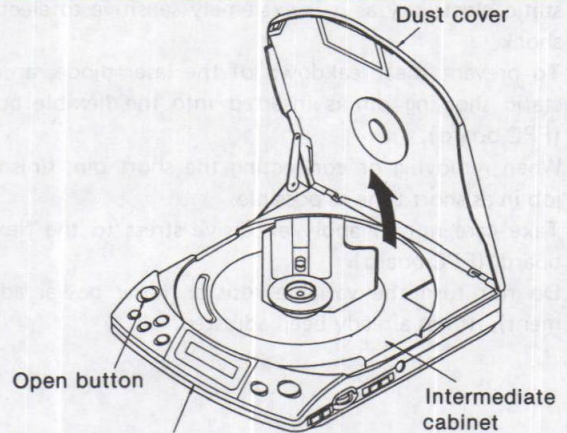

※ Take care not to break a claw.
2. Push the open button and open the dust cover.
3. Remove the intermediate cabinet in the direction of arrow.

Ref. No. 2 **Removal of the traverse deck**

Procedure 1→2

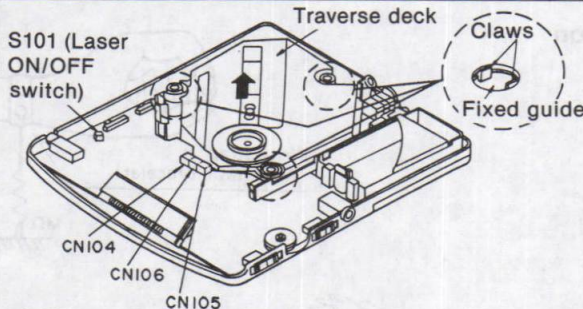

1. Disconnect the connectors (CN104, CN105, CN106).
2. Remove the claws of fixed guide from bottom side.
3. Pull out the traverse deck in the direction of arrow.

How to remove the FPC board.

1. Nip the metal and resin sections of the connector with a pair of pliers and then move the metal section in the direction of arrows ①.

Note:

- The flat edge of the metal section must be nipped.
2. Remove the FPC board in the direction of arrow ②

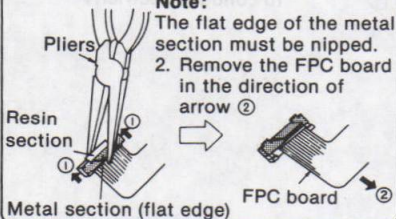

4. Remove the FPC board (CN103).

Caution:

Insert a short pin into the traverse deck's FPC board. (Refer to "handling precautions for traverse deck" on page 5.)

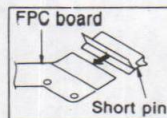

Ref. No. 3 **Removal of the interface P.C.B. and jack P.C.B.**

Procedure 1→2→3

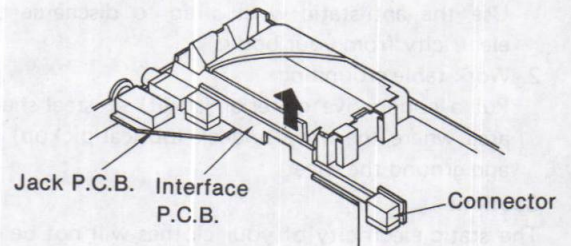

1. Remove the interface P.C.B. in the direction of arrow with carefully.

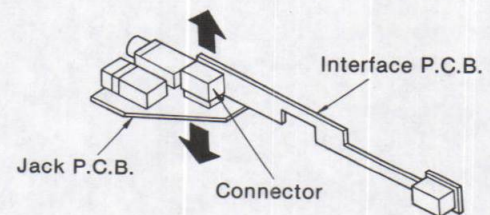

2. Separate the interface P.C.B. and jack P.C.B. in the direction of arrow.

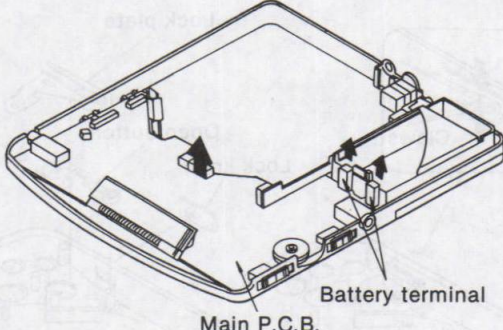
Ref. No. 4	Removal of the main P.C.B.
Procedure 1→2→3→4	
	
<p>• Remove the main P.C.B. and battery terminal.</p>	

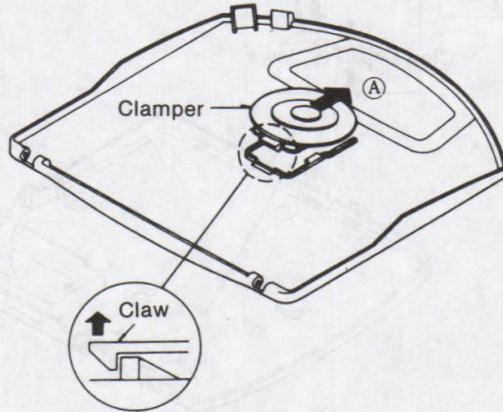
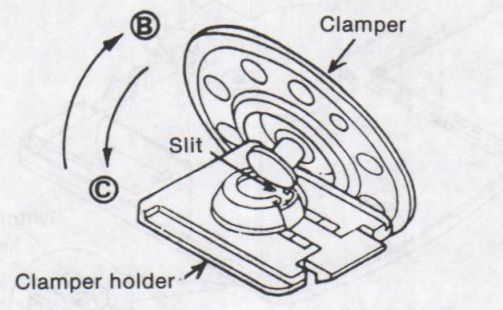
Ref. No. 6	Removal of the clammer
Procedure 1→5→6	<ol style="list-style-type: none"> 1. Remove the claw. 2. Remove the clammer in the direction of arrow A.
	
<ol style="list-style-type: none"> 3. Put together clammer and clammer holder in the direction of slit. 4. Remove the clammer from clammer holder in the direction of arrow B. <p>Note: When attach the clammer, insert it in the direction of arrow C.</p>	
	

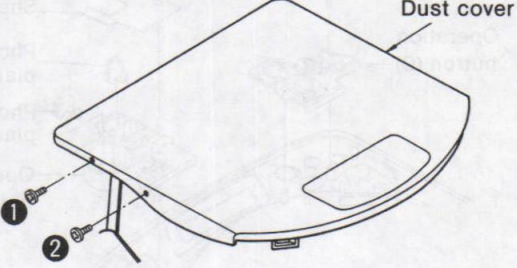
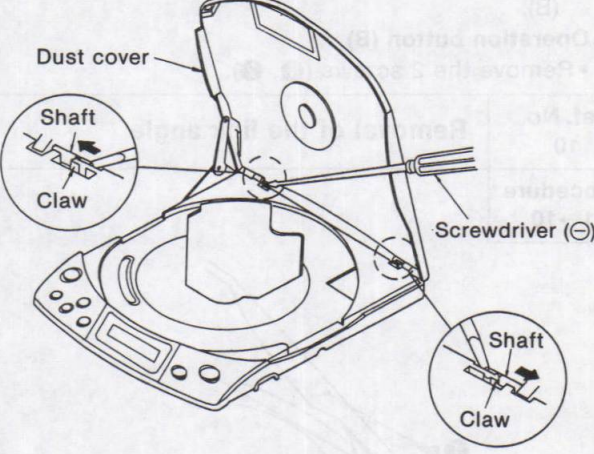
Ref. No. 5	Removal of the dust cover
Procedure 1→5	
	
<ol style="list-style-type: none"> 1. Remove the 2 screws (1, 2). 	
	
<ol style="list-style-type: none"> 2. Use a screwdriver (⊖) or similar tool to push the shafts in the direction of arrow and remove it. 	

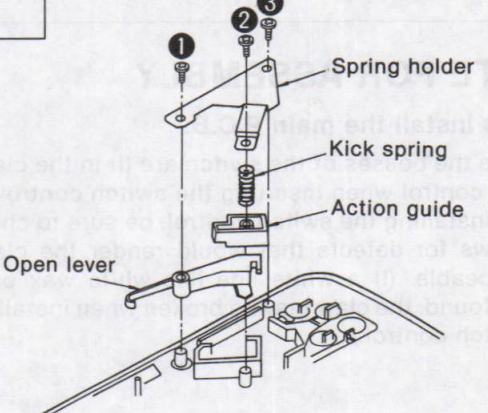
Ref. No. 7	Removal of the kick spring, action guide and open lever
Procedure 1→7	
	
<ol style="list-style-type: none"> 1. Remove the 3 screws (1~3). 2. Remove the spring holder. 3. Remove the kick spring, action guide and open lever. 	

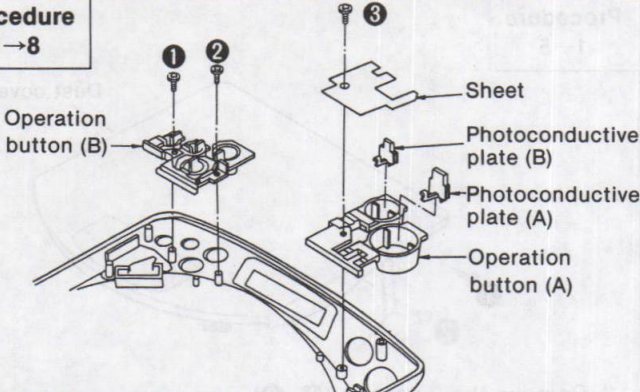
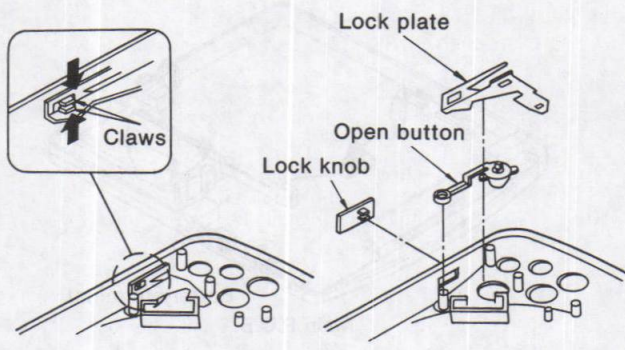
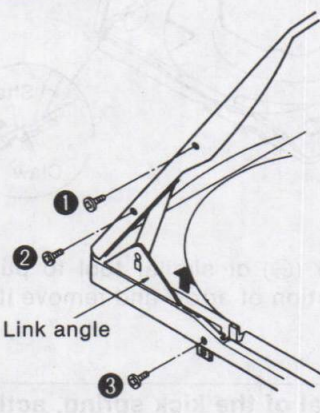
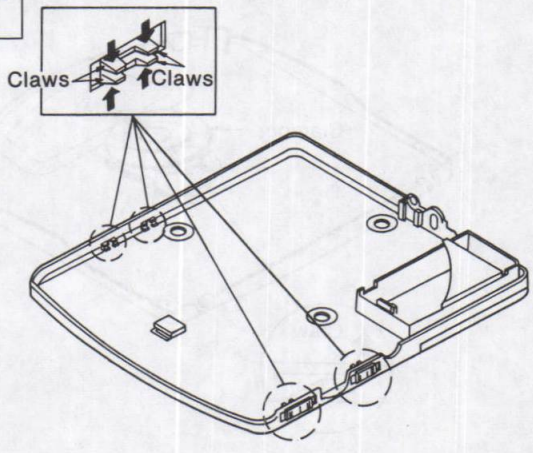
<p>Ref. No. 8</p>	<p>Removal of the operation button (A), (B)</p>	<p>Ref. No. 9</p>	<p>Remove the lock knob and open button</p>
<p>Procedure 1→8</p>	 <p>■ Operation button (A) 1. Remove the 1 screws (③). 2. Remove the sheet and photoconductive plate (A), (B).</p> <p>■ Operation button (B) • Remove the 2 screws (①, ②).</p>	<p>Procedure 1→8→9</p>  <p>1. Push the claw in the direction of arrows, and remove the lock knob. 2. Remove the lock plate and open button.</p>	
<p>Ref. No. 10</p>	<p>Removal of the link angle</p>	<p>Ref. No. 11</p>	<p>Removal of the slide switch knobs</p>
<p>Procedure 1→10</p>	 <p>1. Remove the 3 screws (①~③). 2. Remove the link angle in the direction of arrow.</p>	<p>Procedure 1→2→3→4 →11</p>  <p>• Push the claws in the direction of arrows, and remove the slide switch knobs.</p>	

NOTE FOR ASSEMBLY

• **How to install the main P.C.B.**

Make sure the bosses of the switch are fit in the claws of switch control when inserting the switch control.

* Before installing the switch control, be sure to check the claws for defects that would render the claws unserviceable. (If a white line like white wax on a claw is found, the claw may be broken when installing the switch control.)

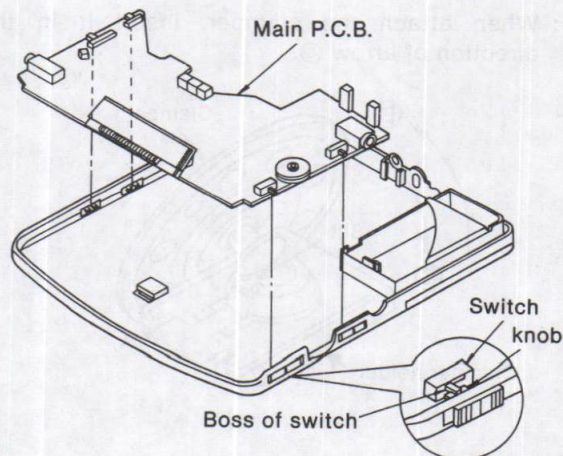

HOW TO CHECK THE MAIN P.C.B.

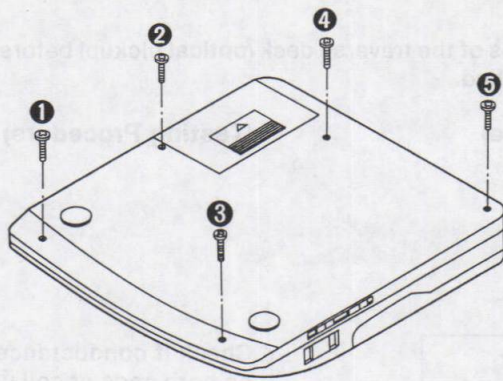

1. Remove the 5 screws (1~5).

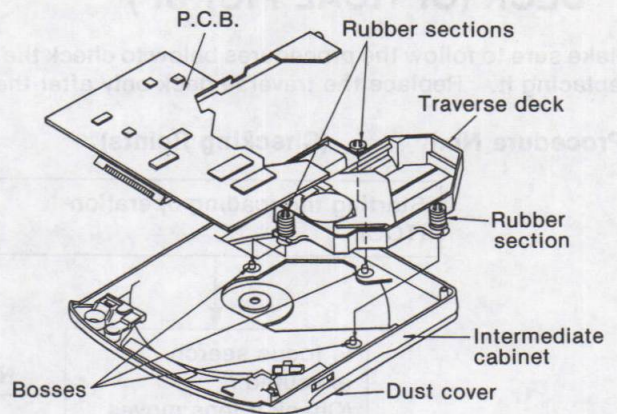

7. Install the traverse deck and P.C.B. in the intermediate cabinet.
8. Install the unit in place by holding the traverse deck and P.C.B. firmly, and then install the disc.

Note: Engage the rubber sections of the traverse deck in the bosses on the intermediate cabinet.

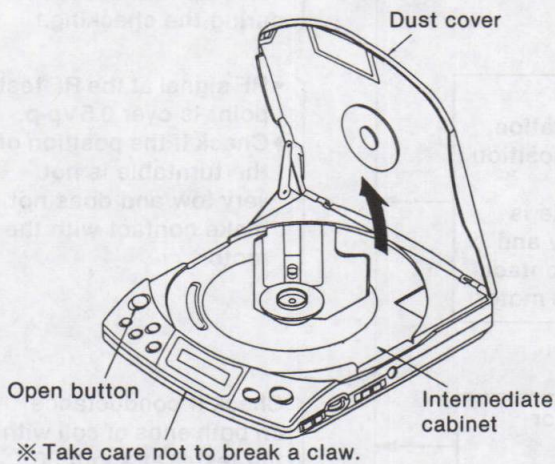

※ Take care not to break a claw.

2. Push the open button and open the dust cover.
3. Remove the intermediate cabinet in the direction of arrow.

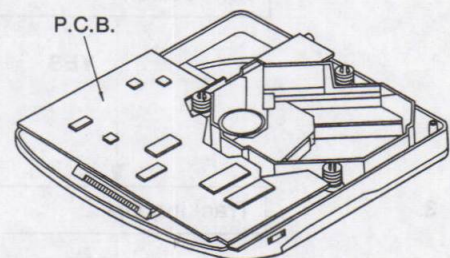

9. With the P.C.B. in place as shown in the figure above, connect the AC adapter to the DC IN jack, press the play button and then check the voltage and waveform.

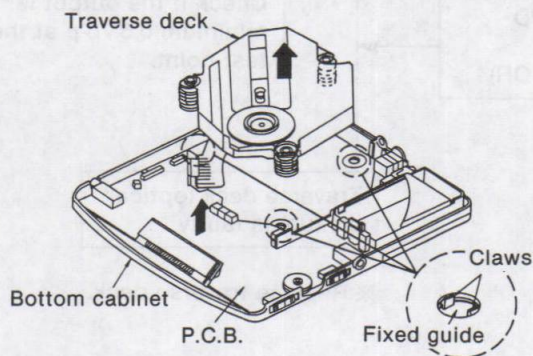

4. Remove the claw of fixed guide, and then remove the traverse deck.
5. Remove the P.C.B. from the bottom cabinet.
6. Short-circuit the lands of the laser ON/OFF SW (S101) by soldering them (See page 16)

Note: After checking the P.C.B., remove the solders from the lands.

■ CHECKING THE OPERATION PROBLEMS ON THE TRAVERSE DECK (OPTICAL PICKUP)

Make sure to follow the procedures below to check the operation problems of the traverse deck (optical pickup) before replacing it. Replace the traverse deck only after the problem is identified.

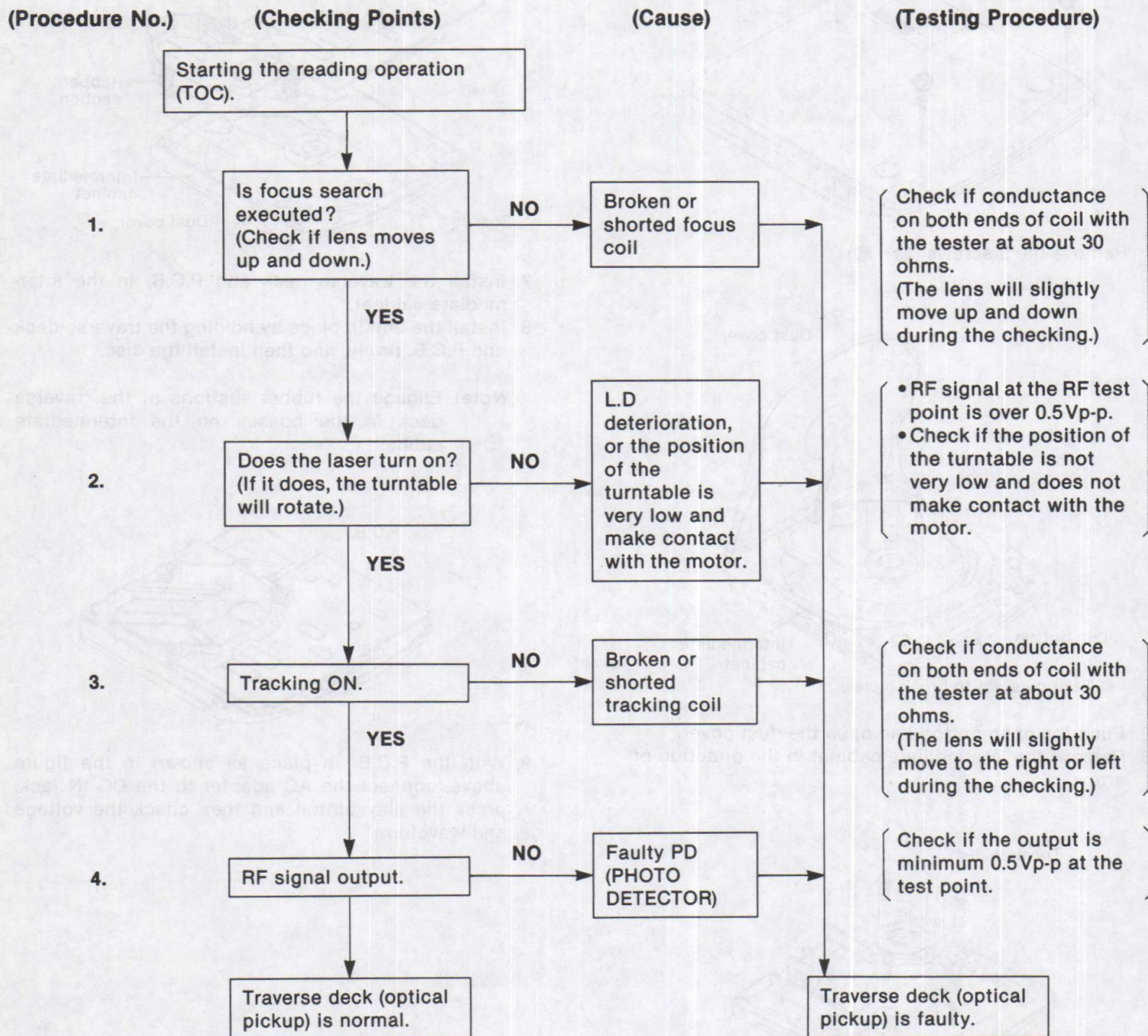

※ Replace traverse deck.

- Check electrical circuit.
- CD is not adjusted properly. Adjust CD again.
 - (1) Mechanical adjustment.
 - (2) Power supply voltage adjustment.
 - (3) Best eye adjustment (PD balance).
 - (4) Focus gain adjustment.
 - (5) Tracking gain adjustment.
 - (6) Focus offset adjustment.
 - (7) Tracking offset adjustment.
 - (8) Tracking balance adjustment.
- Check for flaws on disc or if it is warped or not centered.

Refer to pp. 17~19

※ Checking Operations of Replaced Traverse Deck (New Traverse Deck)

a) Check the operations described below on the traverse deck after replacing it.

* Checking Skip Search

1. Play an ordinary musical program disc.
2. Press the skip button to check for normal skip search operation (in both the forward and reverse directions).

* Checking Manual Search

1. Play an ordinary musical program disc.
2. Press the manual search button to check for smooth manual search operations at either low or high speed (in both the forward and reverse directions).

* Checking Using Defect Disc

1. Play the 0.7mm black dot and the 0.7mm wedge on the playability test disc (SZZP1054C) and verify that no sound skip or noise occurs.
2. Play the middle tracks of the uneven test disc (SZZP1056C) and verify that no sound skip or noise occurs.

b) If the operations are normal, CD adjustments are not required when the traverse deck is replaced.

Note: CD adjustments are required in the cases below. (Mechanical adjustments are not necessary.)
(See item 2-9 on pp. 17~19.)

- If audio is not played back continuously or noises occur after step (a) is executed.
- If the adjustment VRs (VR101~VR106) were rotated before the traverse deck was replaced.
- If the ICs in the servo circuit or adjustment VRs (VR101~VR106) were replaced.

■ NOTE FOR SERVICE

• About hold switch

Before checking the operation problems and adjustments, be sure to release the hold and the lock state.

Note:

Before operating the front panel button, be sure to release the hold and the lock state.

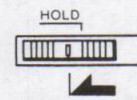

• Connection of the FPC board of the optical pickup

Before you put the power supply to work from the AC adaptor or batteries to check the set's operations and voltage, be sure to connect the FPC board of the optical pickup to the connector CN103 on the main P.C.B. If you disconnected the FPC board from the connector CN103, the transistor Q12 may be damaged when the PLAY/PAUSE button is pressed with the FPC board disconnected.

The note described above does not apply in the case that the FPC board is connected to the connector CN103 during service.

Before turning on the power, make sure that the FPC board is connected to the connector CN103.

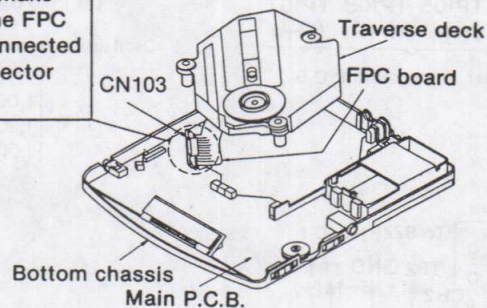

MEASUREMENTS AND ADJUSTMENTS

Warning: This product uses a laser diode. Refer to caution statements on page 3.

Caution: During adjustment, never connect CH-2 probe's GND to any place for it may short Vref line. (Connect CH-1 probe's GND to specified TP. described in each section.)

Measuring Instruments and Special Tools

- * Servo gain adjuster (SZZP1017F or SZZP1094C-1)
- * Test discs
 1. Playability test disc (SZZP1054C)
 2. Uneven test disc (SZZP1056C)
 3. Black band test disc (SZZP1057C)
- * Musical program disc (ordinary)
- * Dual-beam oscilloscope with bandwidth of 30MHz or better (with EXT. trigger and 1:1 probe).
- * Lead wire (for test points)
- * Allen wrench (M2.0) (SZZP1101C)
- * Connector with lead wire (SZZP1074C)
- * DC voltmeter
- * Disc clammer (RXQ0218)
- * New version of the servo gain adjuster
 - * Adaptor C (SZZP1105C)
 - * Adaptor B (SZZP1104)
- * Former version of the servo gain adjuster
 - * Conversion connector (SZZP1032F)
 - * Audio-frequency oscillator

PREPARATION FOR SERVO GAIN ADJUSTER

Using the new version of the servo gain adjuster (SZZP1094C-1)

(For tracking gain, focus gain and tracking balance adjustments.)

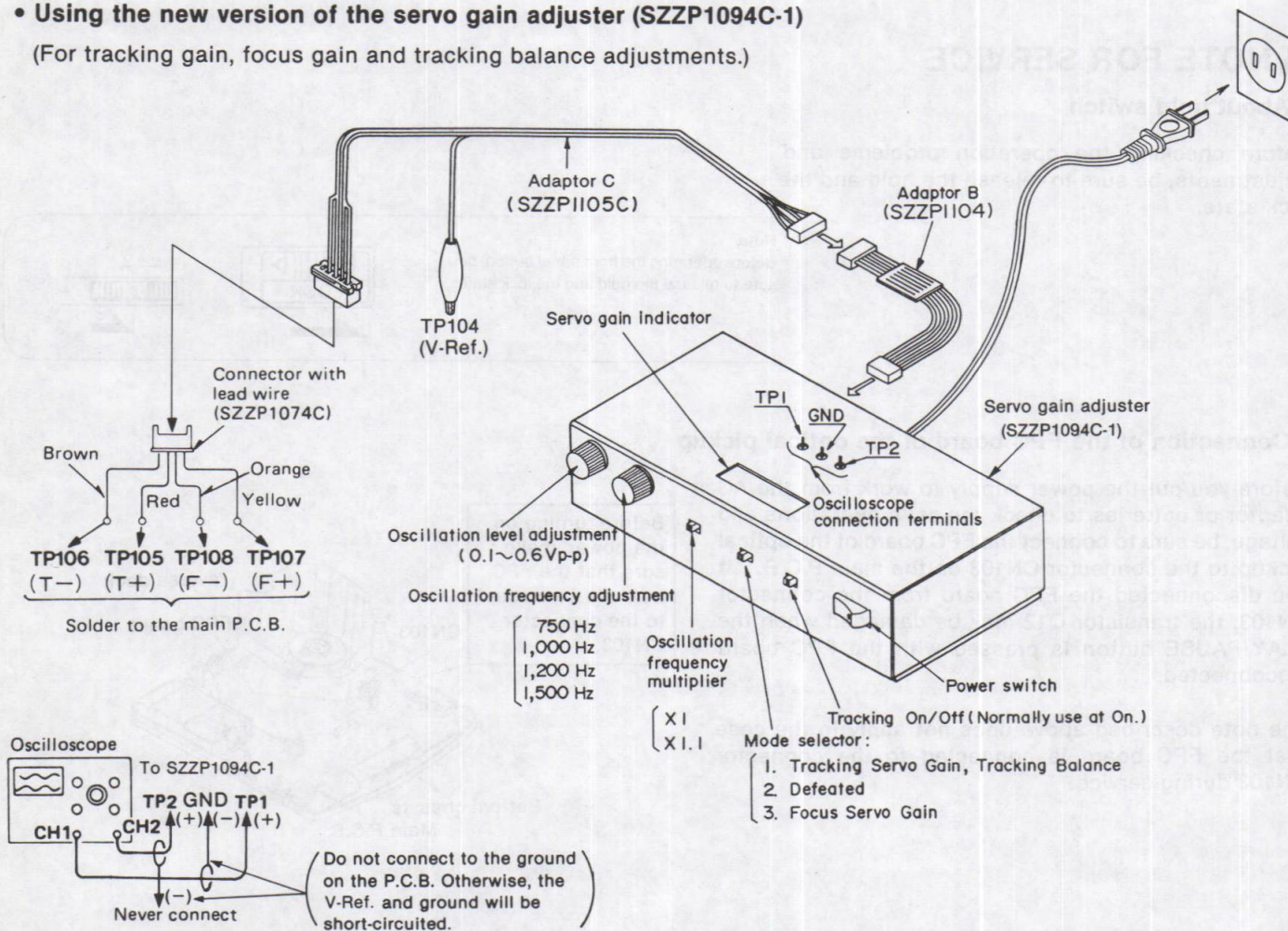

Note: Refer to Notes in focus and tracking gain adjustment on page 18.

• Using the former version of the servo gain adjuster (SZZP1017F)

(For tracking gain, focus gain and tracking balance adjustments.)

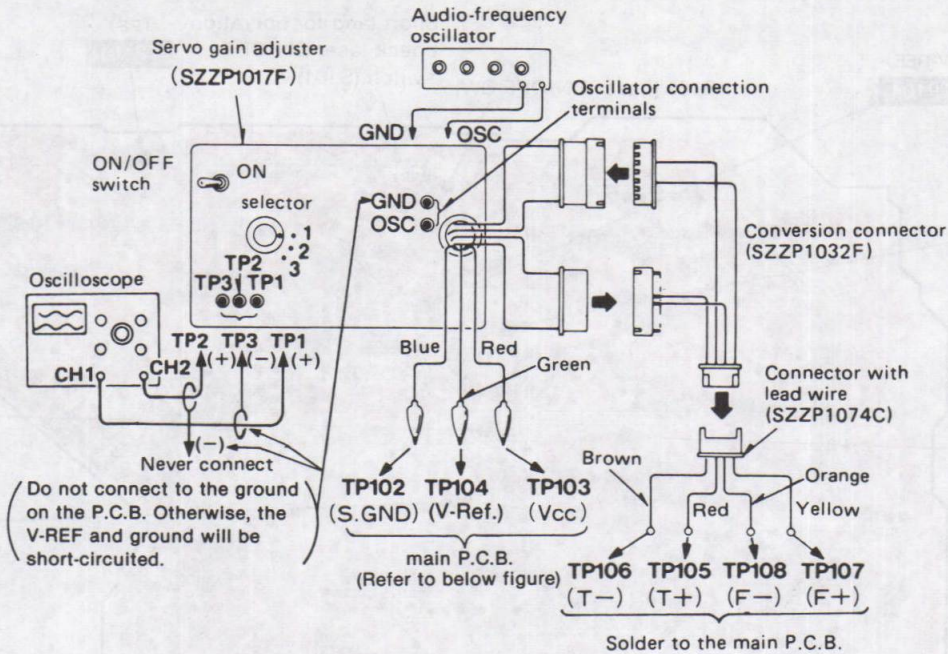

• Connection of oscilloscope

(For best eye, focus offset, tracking offset, tracking balance and mechanical adjustments.)

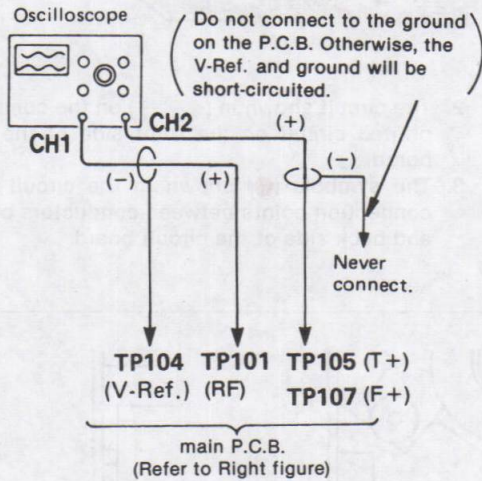

Solder the lead wires to the main P.C.B. (TP101, 102, 103, 104, 105, 106, 107, 108)

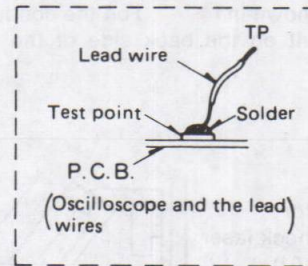

• Precaution for adjustments

1. Remove the intermediate cabinet. (Refer to page 8.)
2. Solder the lead wires and connector with lead wire (SZZP1074C) to the test points on the main P.C.B.
3. Confirm the mechanical center.

In the focus gain adjustment, if VR104 is turned too far, the rotation of the turntable will stop. Turn a little at a time to the right or left from the mechanical center, and then switch on the power. After finding the position at which rotation starts, repeat the adjustment.

• If any of the adjustments is substantially out of adjustment, reset the electrical adjustment VRs back to the mechanical center and readjust.

• Temporary setting of each VR

Temporary VR setting if any of the electrical adjustment VRs are replaced or require re-adjustment, temporarily set them to the following positions:

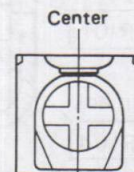

Electrical adjustment VRs

• Test short land

Short-circuit the lands of the laser ON/OFF switch (S101) by soldering them. It turns "ON" position. Refer to the upper figure on page 16.

Note: Remove the solders from the lands after adjustment.

• Test points and adjustment points

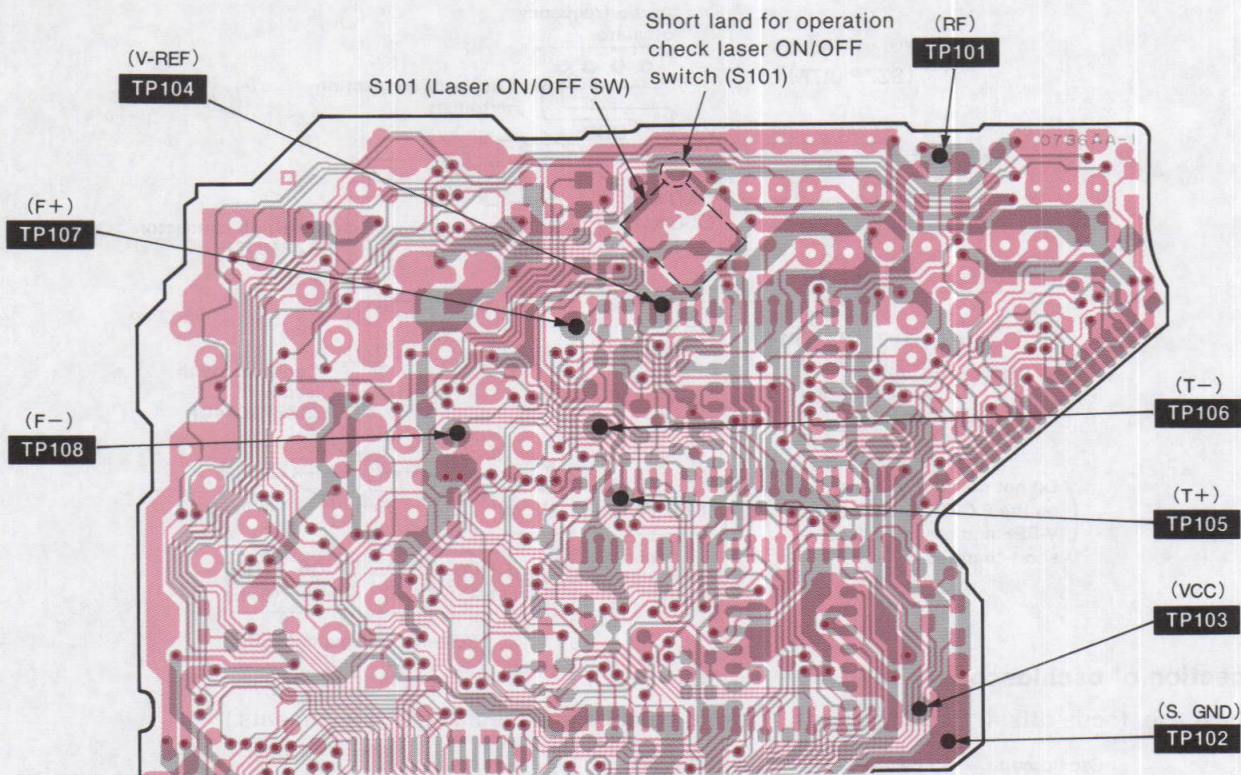

Notes:

This diagram shows a front view of the LCD mounting surface.

1. The circuit shown in (●—●) on the conductor indicates printed circuit on the back side of the printed circuit board.

2. The circuit shown in (○—○) on the conductor indicates printed circuit on the front side of the printed circuit board.

3. The symbols (●) shown in the circuit board indicate connection points between conductors on the front side and back side of the circuit board.

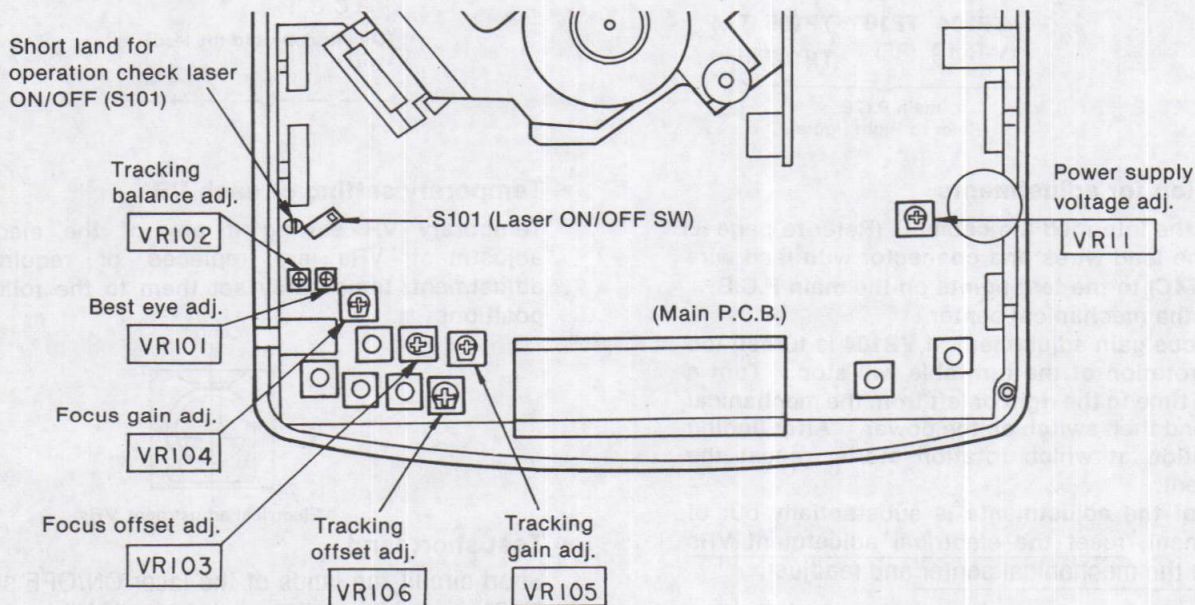

• Adjustment procedure

(1) MECHANICAL ADJUSTMENT

- When the traverse deck is replaced, making adjustments is not necessary. (The traverse deck ass'y is already adjusted.)
- Make adjustments to improve playability if the traverse deck has not been replaced.

1. Connect the oscilloscope's CH. 1 probe across **TP101** (RF) (+) and **TP104** (V-Ref.) (–) on the main P.C.B.
Oscilloscope setting: VOLT100 mV
SWEEP0.5 μ sec.
Input coupling . . AC
2. Switch the player power **ON**, and play track 9 on the test disc (SZZP1056C).
3. Leave the player in play mode, and place it as shown right.
4. Alternately adjust the two mechanical adjusting screws with the 2.0mm allen wrench (SZZP1101C) until the vertical fluctuation of RF signal is minimized and the eye pattern is most stretched.
5. After completing the adjustment, lock the **mechanical adjustments** with lock paint (RZZ0L01).

Note : When adjusting the traverse deck, hold it as shown in the figures.
Adjust it in either of the ways shown in Figure (A) or (B).

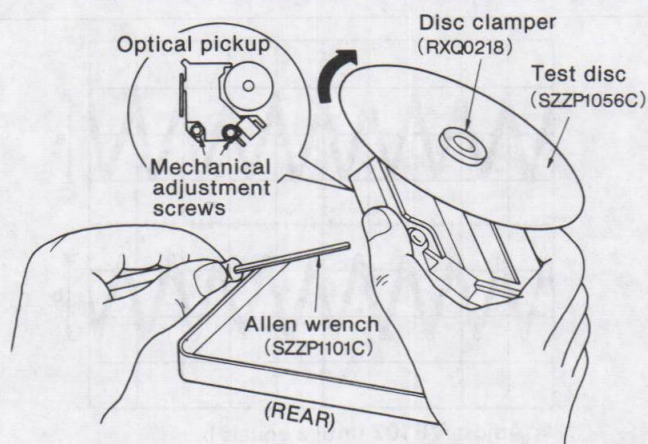

Figure (A)

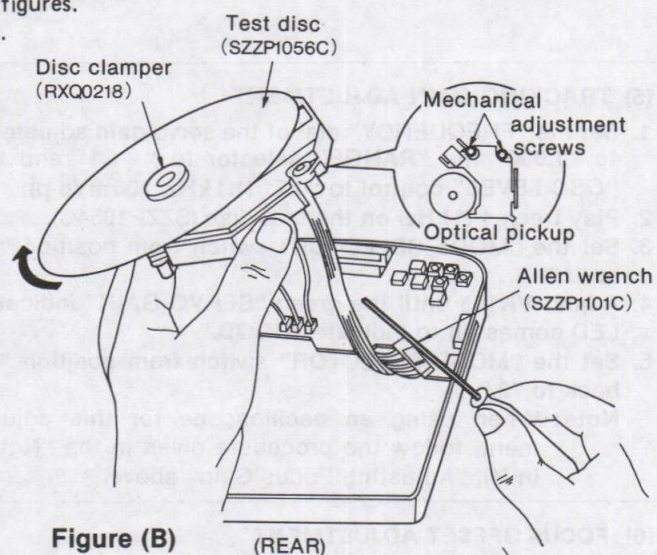
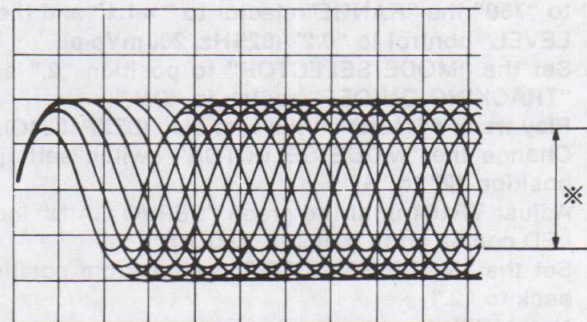

Figure (B)



* Most stretched eye pattern.

(2) POWER SUPPLY VOLTAGE ADJUSTMENT

1. Connect the DC voltmeter to **TP103** (VCC) and **TP102** (S. GND).
2. Insert the test disc, and switch the player power **ON**.

3. Adjust **VR11** on the main P.C.B. at 4.6 ± 0.05 V.

(3) BEST EYE (PD BALANCE) ADJUSTMENT

1. Connect the oscilloscope's CH. 1 probe across **TP101** (RF) (+) and **TP104** (V-Ref.) (–) on the main P.C.B.
Oscilloscope setting: VOLT100 mV
SWEEP0.5 μ sec.
Input coupling . . AC
2. Switch the player power **ON**, and play the 1 kHz (track 1) on the test disc (SZZP1054C).
3. Adjust **VR101** until the vertical fluctuation of RF signal is minimized and the eye pattern is most stretched.

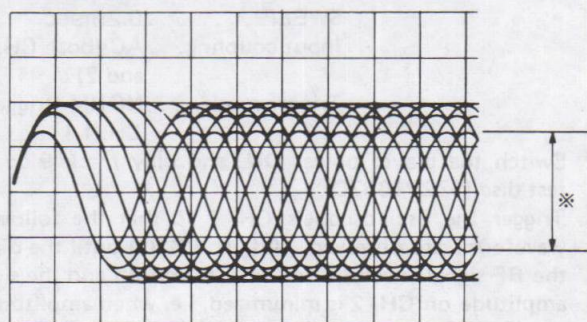

* Most stretched eye pattern.

(4) FOCUS GAIN ADJUSTMENT

1. Set the "FREQUENCY" dial of the servo gain adjuster's to "750" the "RANGE" selector to "x1.1" and the "OSC LEVEL" control to "0.2" (825 Hz, 200mVp-p).
2. Set the "MODE SELECTOR" to position "2," and the "TRACKING ON/OFF" switch to "ON."
3. Play track 1 (1kHz) on the test disc (SZZP1054C).
4. Change the "MODE SELECTOR" switch setting from position "2" to "3."
5. Adjust VR104 until the green "SERVO GAIN" indicator LED comes on to indicate "GOOD."
6. Set the "MODE SELECTOR" switch from position "3" back to "2."

Note: With the new version of the servo gain adjuster, connect TP1, TP2, and TP3 (GND) to an oscilloscope, and you will be able to perform all adjustments while monitoring the waveforms on the oscilloscope screen. Adjust VR104 until the signal amplitude on one channel becomes identical to that on the other, as shown at right. This adjustment procedure also applies with an oscilloscope and audio-frequency oscillator to the former version of the servo gain adjuster.

Oscilloscope setting: VOLT.....100mV
(both channels)
SWEEP1 msec.
Input coupling...AC

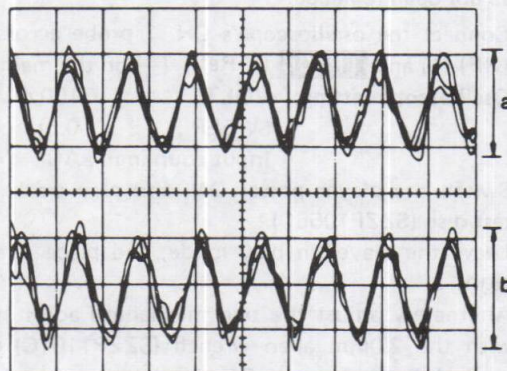

※ Adjust VR104 until a equals b.

(5) TRACKING GAIN ADJUSTMENT

1. Set the "FREQUENCY" dial of the servo gain adjuster's to "1,000" the "RANGE" selector to "x1.1" and the "OSC LEVEL" control to "0.2" (1.1 kHz, 200mVp-p).
2. Play track 1 (1kHz) on the test disc (SZZP1054C).
3. Set the "MODE SELECTOR" switch from position "2" to "1."
4. Adjust VR105 until the green "SERVO GAIN" indicator LED comes on to indicate "GOOD."
5. Set the "MODE SELECTOR" switch from position "1" back to "2."

Note: When using an oscilloscope for this adjustment, follow the procedure given in the "Note" in (4), "Adjusting Focus Gain" above.

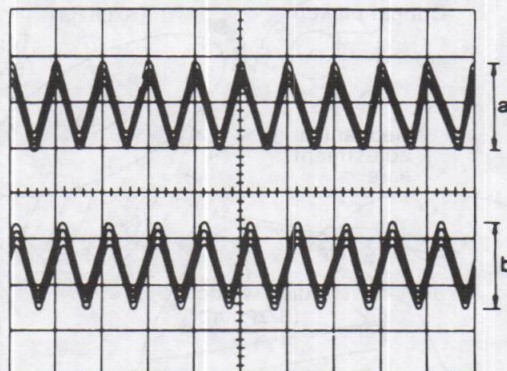

※ Adjust VR102 until a equals b.

(6) FOCUS OFFSET ADJUSTMENT

Note: Set the "MODE SELECTOR" switch of the Servo Gain Adjuster to position "2."

1. Connect the oscilloscope's CH. 1 probe across TP101 (RF) (+) and TP104 (V-Ref.) (-) on the main P.C.B. and its CH. 2 probe (+) to TP107 (F+).

Oscilloscope setting: VOLT.....100mV (CH. 1)
500mV (CH. 2)
SWEEP.....0.2msec.
Input coupling... AC (both CH. 1 and 2)
Trigger mode... NORM (trigger CH. 1.)

2. Switch the player power ON, and play track 9 on the test disc (SZZP1057C).
3. Trigger the oscilloscope's CH. 1 so that the following waveforms are observed. Adjust VR103 until the dip in the RF signal envelope on CH. 1 is smooth and the signal amplitude on CH. 2 is minimized, i.e. when amplitude A equals amplitude B.

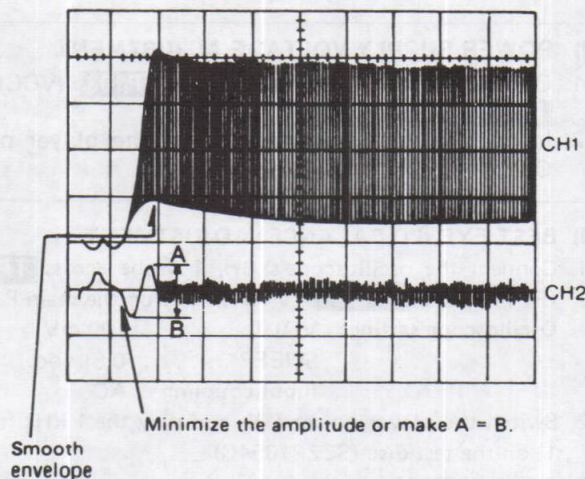

(7) TRACKING OFFSET ADJUSTMENT

Note: Set the "MODE SELECTOR" switch of the Servo Gain Adjuster to position "2."

1. Connect the oscilloscope's CH. 1 probe across TP101 (RF) (+) and TP104 (V-Ref) (-) on the main P.C.B. and its CH. 2 probe (+) to TP105 (T+).
Oscilloscope setting: VOLT..... 100mV (CH. 1)
200mV (CH. 2)
SWEEP..... 0.5msec.
Input coupling... AC (both CH. 1 and 2)
Trigger mode... NORM (trigger CH. 1.)
2. Switch the player power ON, and play track 9 on the test disc (SZZP1057C).
3. Trigger the oscilloscope's CH. 1 so that the following waveforms are observed. Adjust VR106 until the dip in the RF signal envelope on CH. 1 is smooth and the signal amplitude on CH. 2 is minimized, i.e. when amplitude A equals amplitude B.

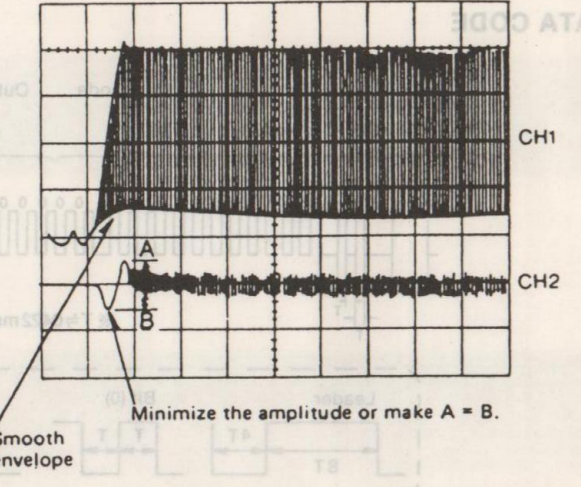

(8) TRACKING BALANCE ADJUSTMENT

1. Set the "FREQUENCY" dial of the servo gain adjuster's to "1,000" th "RANGE" selector to "x1.1" and the "OSC LEVEL" control to "0.6" (1.1kHz, 600mVp-p).
2. Connect the hot lead of the oscilloscope's CH. 1 probe to TP101 (RF) and the cold lead to TP104 (V-Ref).
- * Connect the hot lead of the oscilloscope's CH. 2 probe to TP1 on the servo gain adjuster.

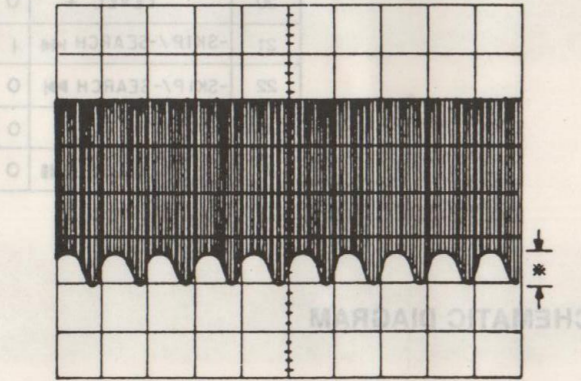

3. Play track 1 (1kHz) on the test disc (SZZP1054C).
4. Set the "MODE SELECTOR" switch of the servo gain adjuster to position "1."
5. The waveform as shown at right will appear on the oscilloscope. Adjust VR102 until the envelope amplitude indicated by the asterisk is minimized uniformly.

(9) CHECK OF PLAY OPERATION AFTER ADJUSTMENT

- * Checking Skip Search
 1. Play an ordinary musical program disc.
 2. Press the skip button to check for normal skip search operation (in both the forward and reverse directions).
- * Checking Manual Search
 1. Play an ordinary musical program disc.
 2. Press the manual search button to check for smooth manual search operations at either low or high speed (in both the forward and reverse directions).

- * Checking Using Defect Disc
 1. Play the 0.7 mm black dot and the 0.7 mm wedge on the defect test disc (SZZP1054C) and verify that no sound skip or noise occurs.
 2. Play the middle tracks of the uneven test disc (SZZP1056C) and verify that no sound skip or noise occurs.

BLOCK DIAGRAM

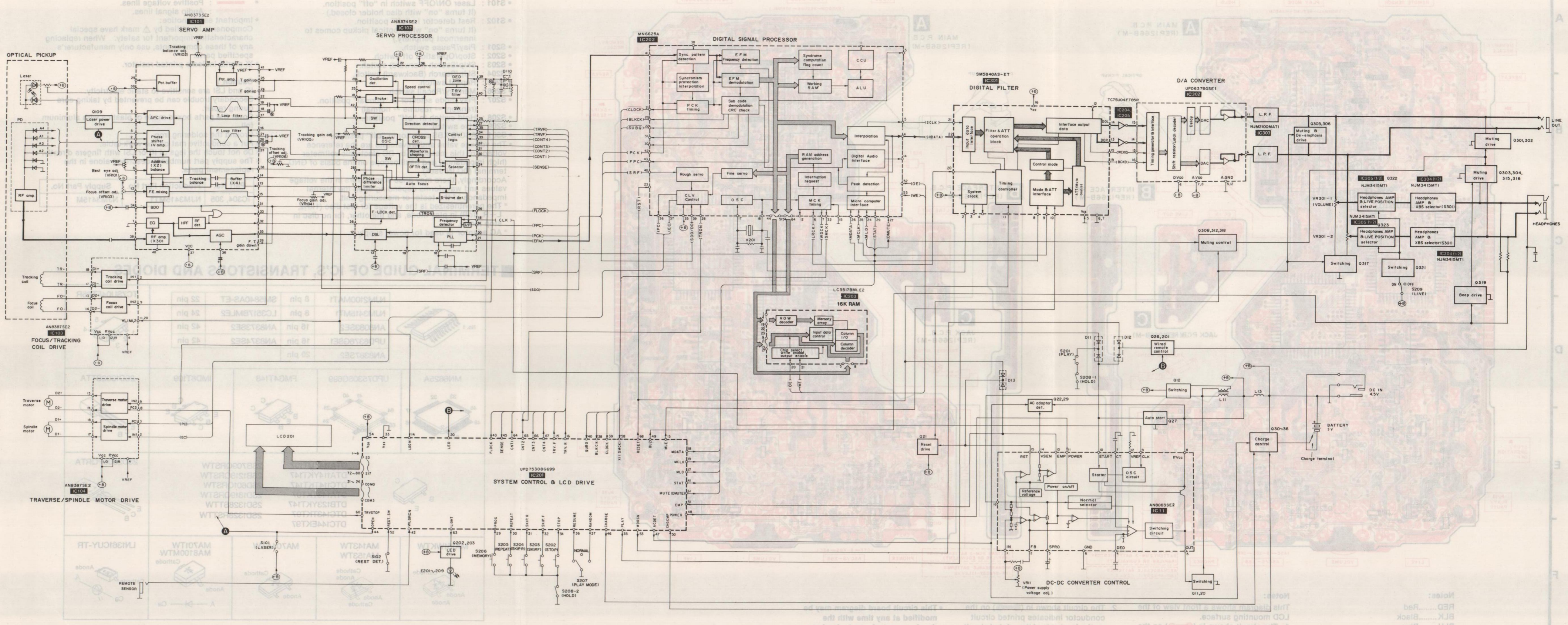

Note: Audio signal

PRINTED CIRCUIT BOARD AND WIRING CONNECTION DIAGRAM

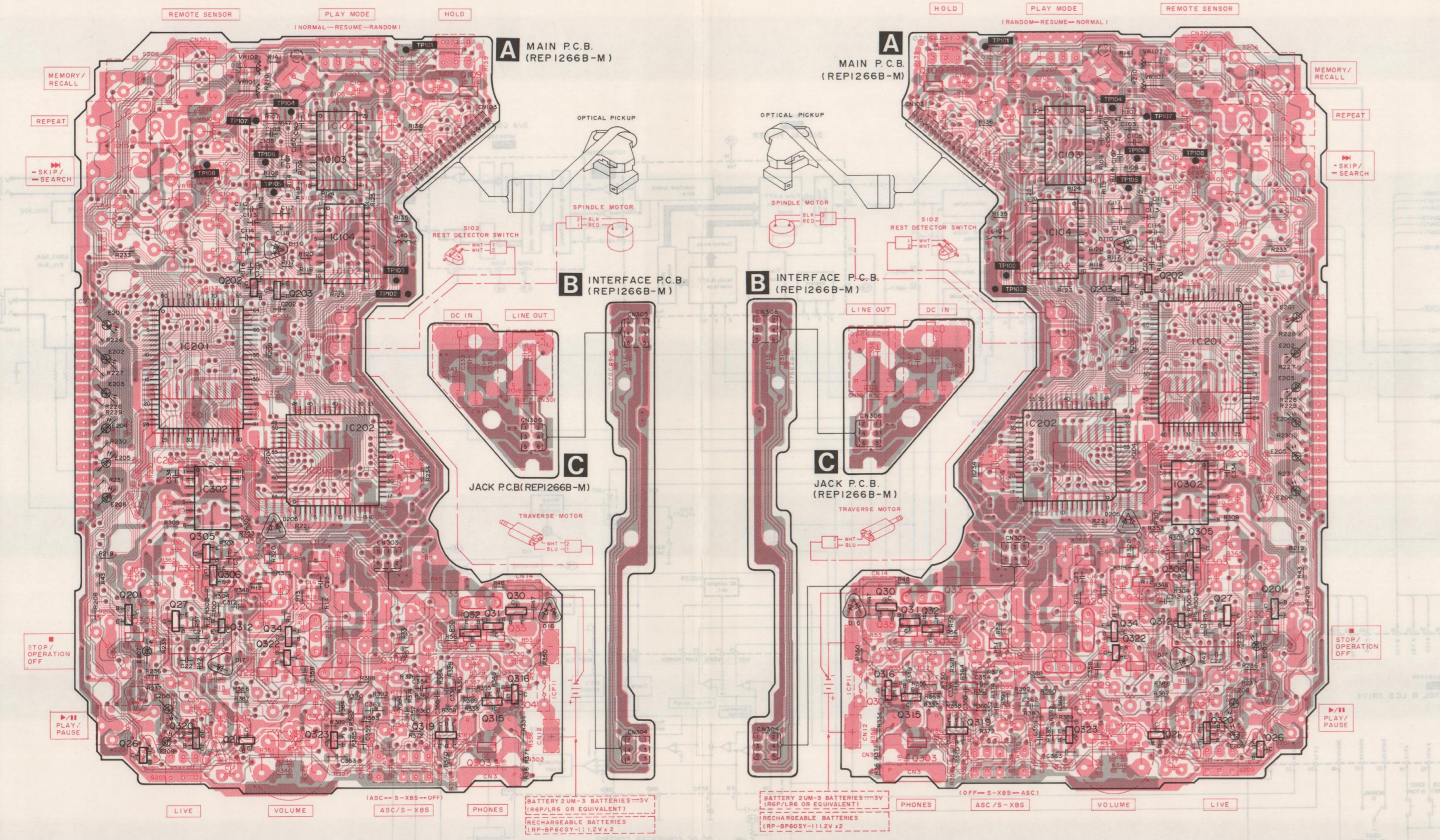

Notes:
 REDRed
 BLKBlack
 BLUBlue
 WHTWhite

Notes:
 This diagram shows a front view of the LCD mounting surface.
 1. The circuit shown in () on the conductor indicates printed circuit on the back side of the printed circuit board.
 2. The circuit shown in () on the conductor indicates printed circuit on the front side of the printed circuit board.
 3. The symbols (●) shown in the circuit board indicate connection points between conductors on the front side and back side of the circuit board.

This circuit board diagram may be modified at any time with the development of new technology.

SCHEMATIC DIAGRAM (Parts list on pages 38~40.)

(This schematic diagram may be modified at any time with the development of new technology.)

Notes:

- S101 : Laser ON/OFF switch in "off" position. (It turns "on" with disc holder closed.)
- S102 : Rest detector in "off" position. (It turns "on" when optical pickup comes to innermost periphery.)
- S201 : Play/Pause switch.
- S203 : Skip/Search (Forward) switch.
- S204 : Skip/Search (Backward) switch.
- S205 : Repeat switch.
- S206 : Memory/Recall switch.
- S207 : Play mode selector in "normal" position. (random → resume → normal)
- S208 : Hold switch in "off" position.
- S209 : Live switch.
- S301 : ASC/S-XBS selector in "off" position.

The voltage value and waveforms are the reference voltage of this measured by DC electronic voltmeter (high impedance) and oscilloscope on the basis of GND terminal (DC IN Jack).
 * The parenthesized is the voltage for test disc (1kHz, L+R, 0dB) in play mode, and the other, for no disc in stop mode.
 * AC adaptor is used for power supply.

Legend:
 — : Positive voltage lines.
 — : Audio signal lines.

Important safety notice:
 Components identified by Δ mark have special characteristics important for safety. When replacing any of these components, use only manufacturer's specified parts.
 * marks indicate printed resistor.

Caution!
 IC and LSI are sensitive to static electricity. Secondary trouble can be prevented by taking care during repair.
 * Cover the parts boxed made of plastics with aluminum foil.
 * Ground the soldering iron.
 * Put a conductive mat on the work table.
 * Do not touch the legs of IC or LSI with fingers directly.
 * The supply part number is described alone in the replacement parts.

Part No.	Production Part No.	Supply Part No.
IC304, 305	NJM3415MT1	NJM3415M

TERMAL GUIDE OF IC'S, TRANSISTORS AND DIODES

	NJM2100MAT1 8 pin	SM5840AS-ET 22 pin	TC7SU04FT85R
	NJM3415MT1 8 pin	LC3517BMLE2 24 pin	
	AN8083SE2 16 pin	AN8373SE2 42 pin	
	UPD6376GE1 16 pin	AN8374SE2 42 pin	
	AN8387SE2 20 pin		
	MN6625A	UPD75308G699	FMG4T148
			IMD6T109
			2SD1302STTA
	DTA114TUT107	2SB709QRSTW	2SD2005PQRTA
	DTA114YKT147	2SB1218QRSTW	
	DTC114TKT147	2SD601QRSTW	
	DTA143TKT97	2SD1819QRSTW	
	DTB123YKT147	2SD1328STTW	
	DTC143TKT97	2SD1328RSTTW	
	MA151WKTW	MA143TW	MA701TW
		MA153TW	MA8100MTW
			LN1361CUY-TR

REMOTE CONTROL TRANSMITTER (EURSBFA06NT)

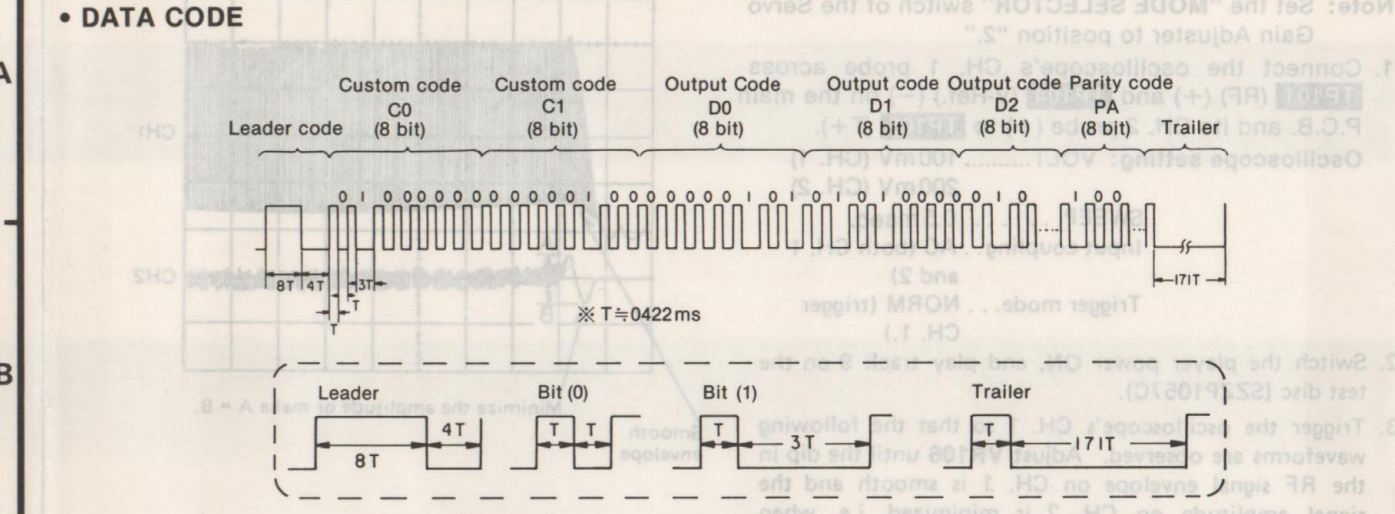

SCHEMATIC DIAGRAM

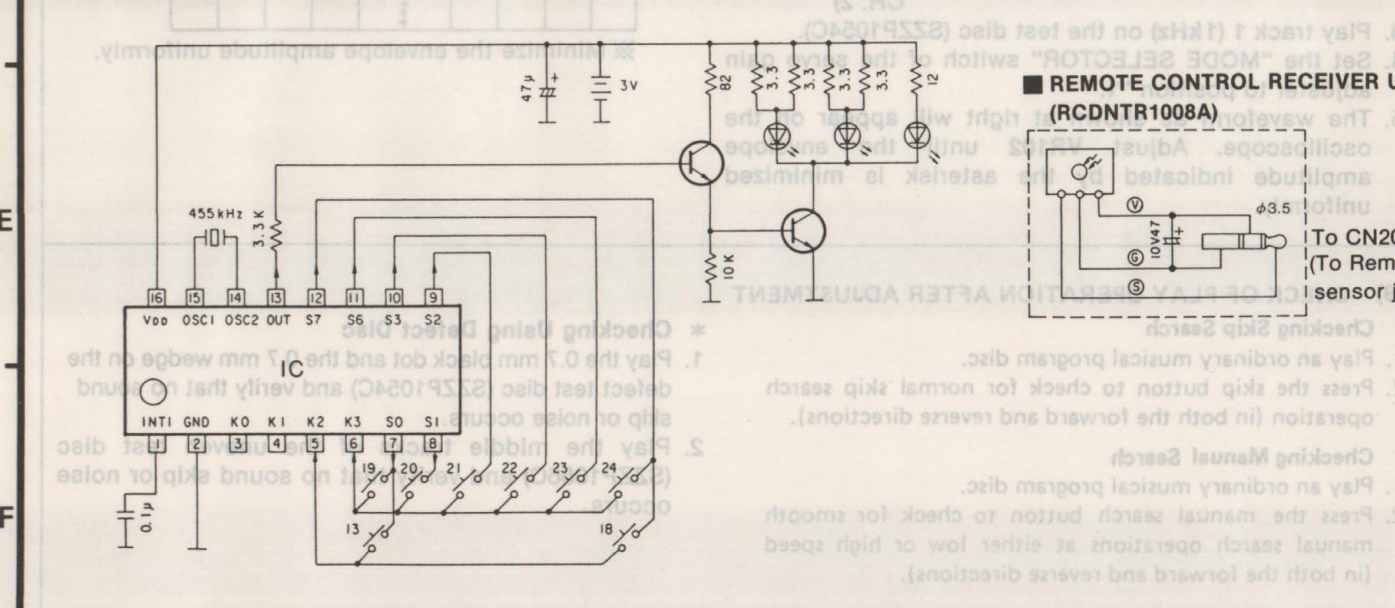

A MAIN CIRCUIT

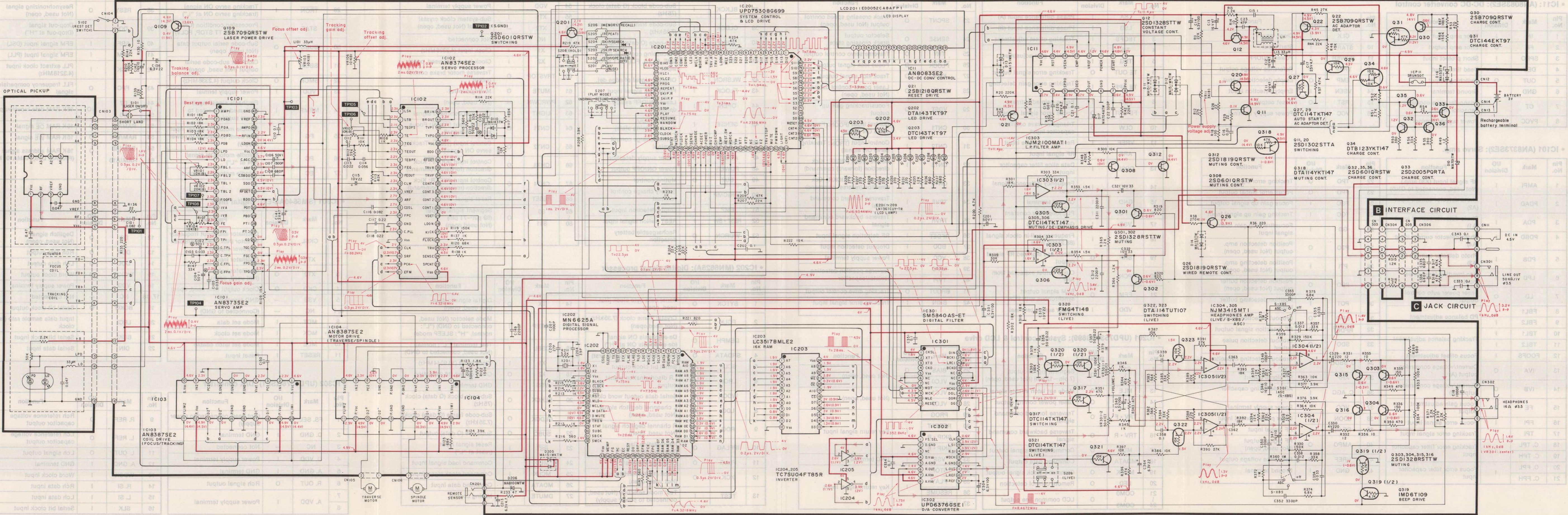

• IC103, 104 (AN8387SE2): Traverse & spindle motor drive

Pin No.	Mark	I/O Division	Function
1	S. VCC	I	Power supply terminal
2	IN1	I	Spindle motor drive signal input and tracking coil drive signal input
3	PC1	I	Spindle motor ON signal input
4	VREF	I	Reference voltage input
5	P. GND	I	Ground terminal
6			
7	S. GND	I	Ground terminal
8	PC2	I	Traverse motor brake control input
9	IN2	I	Traverse motor drive signal input and focus coil drive signal input

Pin No.	Mark	I/O Division	Function
10	S. VCC	I	Power supply terminal
11	VLIM2	I	Voltage limit terminal
12	P. VCC	I	Power supply terminal
13	D2+	O	Traverse motor drive signal output and focus coil drive signal output
14	D2-		
15	P. GND	I	Ground terminal
16			
17	D1-	O	Spindle motor drive signal output and tracking coil drive signal output
18	D1+		
19	P. VCC	I	Power supply terminal
20	VLIM1	I	Voltage limit terminal

■ INTERNAL CONNECTIONS OF LCD

• Common connection diagram

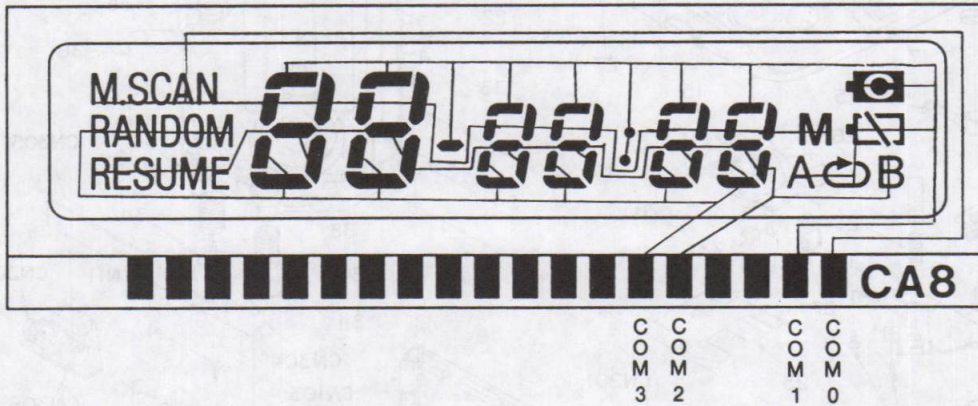

• Segment connection diagram

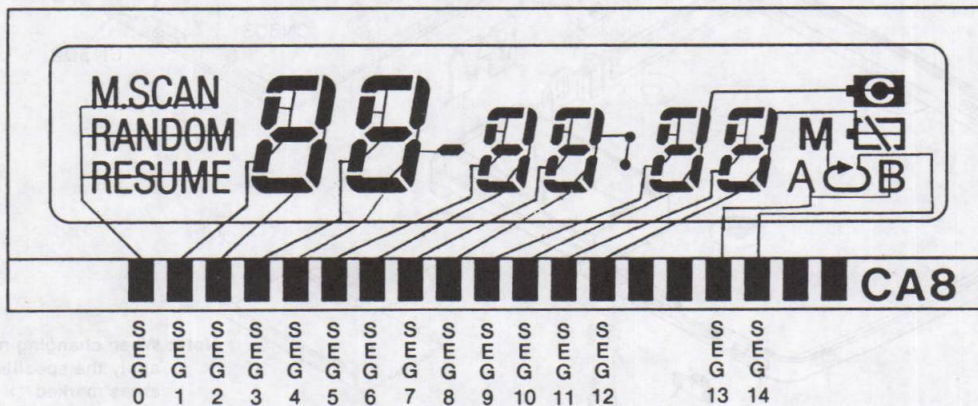

1 2 3 4 5

EXPLODED VIEW

The parts enclosed in the dotted boxes are supplied as a block assembly. Therefore, they are not supplied separately except parts indicated with Ref. No.

A
B
C
D
E
F
G

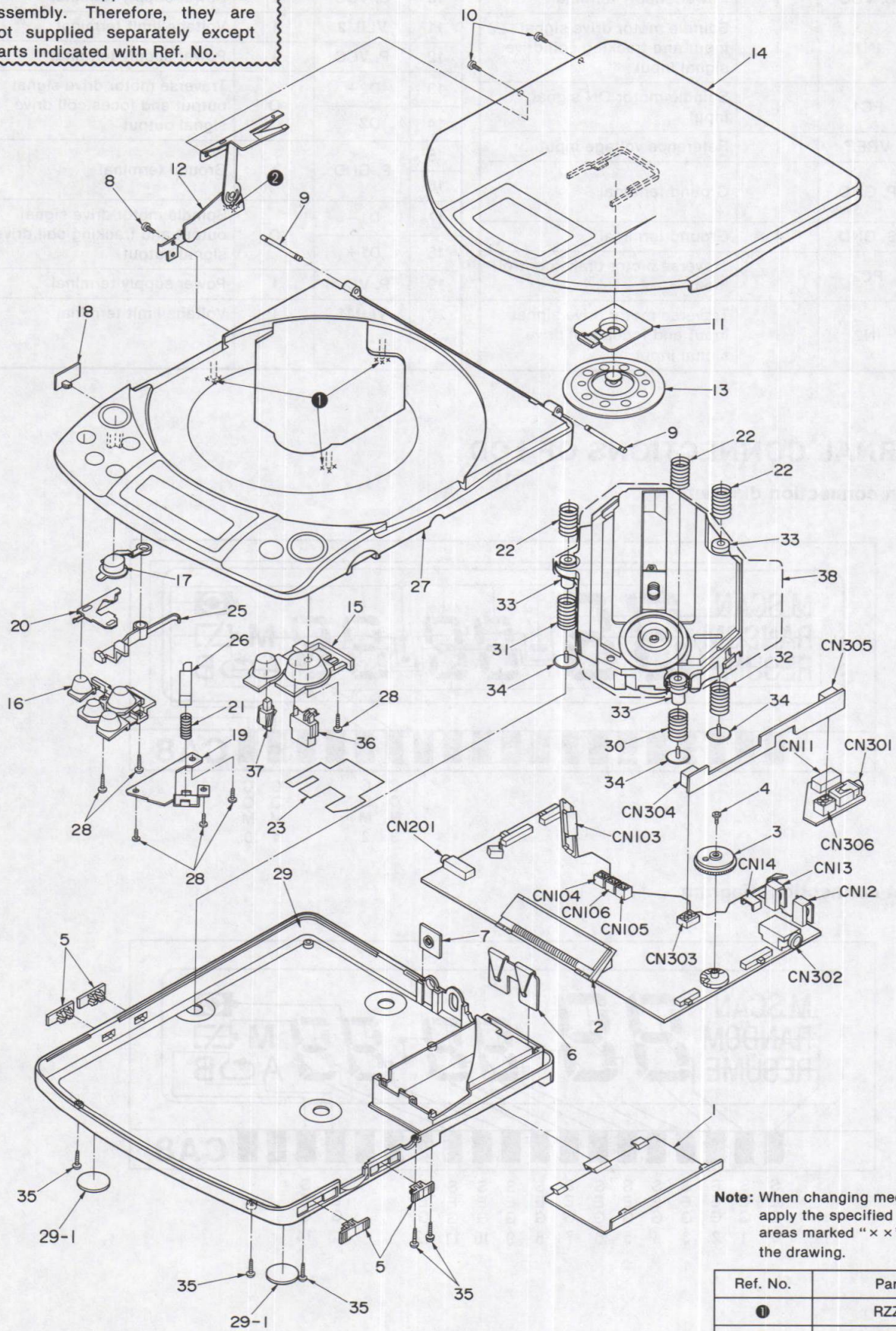

Note: When changing mechanism parts, apply the specified grease to the areas marked "x x" as shown in the drawing.

Ref. No.	Part No.
①	RZZ0L05
②	SZZ0L18

REPLACEMENT PARTS LIST

Notes : * Important safety notice:

Components identified by Δ mark have special characteristics important for safety. When replacing any of these components use only manufacturer's specified parts.

* The parenthesized indications in the Remarks columns specify the areas. (Refer to the cover page for area.)
Parts without these indications can be used for all areas.

* Warning: This product uses a laser diode. Refer to caution statements on page 3.

* ACHTUNG:

Die Lasereinheit nicht zerlegen.

Die Lasereinheit darf nur gegen eine vom hersteller spezifizierte einheit ausgetauscht werden.

Ref. No.	Part No.	Part Name & Description	Remarks	Ref. No.	Part No.	Part Name & Description	Remarks
		CABINET AND CHASSIS		P1	RPK0311	PACKING CASE	
				P2	RPN0367-1	CUSHION (TOP)	
				P3	RPN0368	CUSHION (BOTTOM)	
1	RKK0009-3K	BATTERY COVER		P4	SPPD1	PROTECTION BAG (UNIT)	
2	RJF0009	LCD HOLDER		P5	SPSD14	PROTECTION SHEET (T. T.)	
3	SBND90ZKDA	KNOB, H. P. VOLUME		P6	RPQF0017	ACCESSORIES BOX	
4	XQN17+C3FZ	SCREW		P7	RPQ0059	SPACER	(EG, GN)
5	RGV0068-1K	KNOB, ASC/LIVE/HOLD/P. MODE		P8	RPQ0199	PAD	(EG)
6	RJC93007	BATTERY TERMINAL (COMMON)		P8	RPQ0200	PAD	(EB, GC)
7	RMA0110	ANGLE		P8	RPQ0202	PAD	(GN)
8	RHE5155YA	SCREW		P9	RPF0046	PROTECTION BAG (F. B.)	
9	RMS0105-1	SHAFT				ACCESSORIES	
10	RHE5097ZA	SCREW					
11	RMQ0163-1	CLAMPER HOLDER		A1	RFKSLXP505EG	INST. MANUAL ASS' Y	(EG)
12	RXA0117	LINK ANGLE ASS' Y		A1	RQT1400-B	INST. MANUAL	(EB)
13	RXQ0218	CLAMPER ASS' Y		A1	RQT1398-G	INST. MANUAL	(GC)
14	RYF0171A-K	DUST COVER		A1	RQT1400-B	INST. MANUAL	(GN)
15	RGU0656	BUTTON, OPERATION A		A2	RQA0013	WARRANTY CARD	(EG, EB)
16	RGU0657	BUTTON, OPERATION B		A2	RQX7433ZA	WARRANTY CARD	(GN)
17	RGU0658	BUTTON, OPEN		A3	RQCB0169	SERVICENTER LIST	
18	RGV0090	KNOB, LOCK		A4	EURSBFA06NT	REMOTE CONTROL TRANSMITTER	
19	RMA0519	SPRING HOLDER		A5	RCDNTR1008A	REMOTE CONT. RECEIVER UNIT	
20	RMA0540	LOCK PLATE		A6	RFEA401E-1S	AC ADAPTOR	(EG) Δ
21	RMB0213	SPRING (KICK)		A6	RFEA401B-W	AC ADAPTOR	(EB) Δ
22	RMB0221	FLOATING SPRING B (BLACK)		A6	RFEA402Z-W	AC ADAPTOR	(GC) Δ
23	RMV0048	SHEET		A6	RFEA401A-W	AC ADAPTOR	(GN) Δ
25	RML0233	OPEN LEVER		A7	RFEV102A-K2S	STEREO EARPHONES	
26	RMR0488	ACTION GUIDE		A8	SH-CDB8-3	RECHARGEABLE BATTERIES	(EG, EB)
27	RYK0287A-K	INTERMEDIATE CABINET ASS' Y		A8	SH-CDB8-2	RECHARGEABLE BATTERIES	(GC, GN)
28	XTN17+4J	SCREW		A9	SJPD5-2K	STEREO CONNECTION CABLE	
29	RFKJLXP505EG	BOTTOM CABINET ASS' Y	(EG)	A10	RJP120ZDS-K	AC PLUG ADAPTOR	(GC) Δ
29	RFKJLXP505EB	BOTTOM CABINET ASS' Y	(EB, GC, GN)	A11	RKB205ZA-0	EAR PAD	
29-1	SHGD54-1	FOOT				<PRINTED CIRCUIT BOARDS	
30	RMB0223	FLOATING SPRING D (SILVER)				ASS' Y>	
31	RMB0227	FLOATING SPRING E (GREEN)		PCB1	REP1266B-M	MAIN P. C. B.	(NLA)
32	RMB0228	FLOATING SPRING F (RED)				INTERFACE P. C. B.	
33	RMG0229	FLOATING RUBBER				JACK P. C. B.	
34	RMR0530-K	FIXED GUIDE					
35	XTN17+6GFZ	SCREW					
36	RMR0527	PHOTOCONDUCTIVE PLATE (A)					
37	RMR0528	PHOTOCONDUCTIVE PLATE (B)					
38	SODD100Z	TRAVERSE DECK UNIT					
		PACKING MATERIAL (S)					

Note: Printed circuit board assembly with mark (NLA) is no longer available after discontinuation of the product.

Ref. No.	Part No.	Part Name & Description	Remarks
		INTEGRATED CIRCUIT(S)	
IC11	AN8083SE2	IC, DC-DC CONV. CONTROL	
IC101	AN8373SE2	IC, SERVO AMP	
IC102	AN8374SE2	IC, SERVO PROCESSOR	
IC103, 104	AN8387SE2	IC, COIL/MOTOR DRIVE	
IC201	UPD75308G699	IC, SYSTEM CONTROL&LCD DRIVE	
IC202	MN6625A	IC, DIGITAL SIGNAL PROCESSOR	
IC203	LC3517BMLE2	IC, 16K RAM	
IC204, 205	TC7SU04FT85R	IC, INVERTER	
IC301	SM5840AS-ET	IC, DIGITAL FILTER	
IC302	UPD6376GSE1	IC, D/A CONVERTER	
IC303	NJM2100MAT1	IC, L. P. F.	
IC304, 305	NJM3415M	IC, HEADPHONES AMP	
		TRANSISTOR(S)	
Q11	2SD1302STTA	TRANSISTOR	
Q12	2SD1328STTW	TRANSISTOR	
Q20	2SD1302STTA	TRANSISTOR	
Q21	2SB1218QRSTW	TRANSISTOR	
Q22	2SB709QRSTW	TRANSISTOR	
Q26	2SD1819QRSTW	TRANSISTOR	
Q27	DTC114TKT147	TRANSISTOR	
Q29	DTC114TKT147	TRANSISTOR	
Q30	2SB709QRSTW	TRANSISTOR	
Q31	DTC144EKT97	TRANSISTOR	
Q32	2SD601QRSTW	TRANSISTOR	
Q33	2SD2005PQRTA	TRANSISTOR	
Q34	DTB123YKT147	TRANSISTOR	
Q35, 36	2SD601QRSTW	TRANSISTOR	
Q109	2SB709QRSTW	TRANSISTOR	
Q201	2SD601QRSTW	TRANSISTOR	
Q202	DTA143TKT97	TRANSISTOR	
Q203	DTC143TKT97	TRANSISTOR	
Q301-304	2SD1328RSTTW	TRANSISTOR	
Q305, 306	DTC114TKT147	TRANSISTOR	
Q308	2SD601QRSTW	TRANSISTOR	
Q312	2SD1819QRSTW	TRANSISTOR	
Q315, 316	2SD1328RSTTW	TRANSISTOR	
Q317	DTC114TKT147	TRANSISTOR	
Q318	DTA114YKT147	TRANSISTOR	
Q319	IMD6T109	TRANSISTOR	
Q320	FMG4T148	TRANSISTOR	
Q321	DTC114TKT147	TRANSISTOR	
Q322, 323	DTA114TUT107	TRANSISTOR	
		DIODE(S)	
D10	MA701TX	DIODE	
D11-13	MA151WK	DIODE	

Ref. No.	Part No.	Part Name & Description	Remarks
D14	MA153-TW	DIODE	
D16	MA153-TW	DIODE	
D17	MA704ATW	DIODE	
D110	MA143TW	DIODE	
D205	MA151WK	DIODE	
D206	MA8100MTW	DIODE	
E201-209	LN1361CUY-TR	LED	
		IC PROTECTOR(S)	
ICP11	SRUN50T	IC PROTECTOR	
		VARIABLE RESISTOR(S)	
VR11	EVNDXAA00B33	V. R, POWER SUPPLY VOLT. ADJ.	
VR101	EVMIYSX30B14	V. R, BEST EYE ADJ.	
VR102	EVMIYSX30B24	V. R, TRACKING BALANCE ADJ.	
VR103	EVNDXAA00B14	V. R, FOCUS OFFSET ADJ.	
VR104	EVNDXAA00B14	V. R, FOCUS GAIN ADJ.	
VR105	EVNDXAA00B14	V. R, TRACKING GAIN ADJ.	
VR106	EVNDXAA00B14	V. R, TRACKING OFFSET ADJ.	
VR301	EVUBPAT50C54	V. R, VOLUME	
		COIL(S)	
L11	RLZ0007-0	COIL	
L13	RLQB330KT-K	COIL	
L101	SLQDNL330KT	COIL	
		OSCILLATOR(S)	
X201	RSXZ16M9M01T	OSCILLATOR	
		LCD	
LCD201	EDD052CA8AFP	LCD	
		JACK(S) & CONNECTOR(S)	
CN11	RJ4303-1	DC IN JACK	
CN12, 13	RJC30002-3	BATTERY TERMINAL	
CN14	RJH5102-1	RECHARGEABLE BATT. TERMINAL	
CN103	RJS1A6116	CONNECTOR(16P)	
CN104-106	EMCS0255B	CONNECTOR(2P)	
CN201	RJJD3S5ZA-C	REMOTE SENSOR JACK	
CN301	RJJD3S5ZA-C	LINE OUT JACK	
CN302	RJJD5S3MZA-C	HEADPHONES JACK	
CN303	RJT059W006	CONNECTOR(6P)	
CN304, 305	RJU059W006	CONNECTOR(6P)	
CN306	RJT059W006	CONNECTOR(6P)	
		SWITCH(ES)	

Ref. No.	Part No.	Part Name & Description	Remarks
S101	RSH1A91ZA-A	SW, LASER ON/OFF	
S102	SSHD5	SW, REST DETECTOR	
S201	EVQQTJ05R	SW, PLAY/PAUSE	
S202	EVQQTJ05R	SW, STOP/OPERATION OFF	
S203	EVQQTJ05R	SW, F. SKIP/SEARCH	
S204	EVQQTJ05R	SW, B. SKIP/SEARCH	

Ref. No.	Part No.	Part Name & Description	Remarks
S205	EVQQTJ05R	SW, REPEAT	
S206	EVQQTJ05R	SW, MEMORY/RECALL	
S207	ESD11H230	SW, PLAY MODE SELECTOR	
S208	ESD11H220	SW, HOLD	
S209	ESD11H220	SW, LIVE	
S301	ESD11H230	SW, ASC/S-XBS SELECTOR	

RESISTORS & CAPACITORS

Notes : * Capacity value are in microfarads (μF) unless specified otherwise, P=Pico-farads (pF) F=Farads (F)
 * Resistance values are in ohms, unless specified otherwise, 1K=1,000 (OHM) , 1M=1,000k (OHM)

Ref. No.	Part No.	Values & Remarks	Ref. No.	Part No.	Values & Remarks	Ref. No.	Part No.	Values & Remarks
		RESISTOR(S)	R56	ERJ3GEYJ333V	1/16W 33K	R200	ERJ3GEYJ472V	1/16W 4.7K
			R57	ERJ3GEYJ473V	1/16W 47K	R204, 205	ERJ3GEYJ223V	1/16W 22K
			R101-104	ERJ3GEYJ183V	1/16W 18K	R207	ERJ6GEYJ223V	1/10W 22K
R11	ERJ3GEYJ223V	1/16W 22K	R107, 108	ERJ3GEYJ102V	1/16W 1K	R208	ERJ3GEYJ392V	1/16W 3.9K
R12	ERJ3GEYJ272V	1/16W 2.7K	R109	ERJ3GEYJ153V	1/16W 15K	R209	ERJ3GEYJ473V	1/16W 47K
R13	ERJ3GEYJ222V	1/16W 2.2K	R111	ERJ6GEYJ103V	1/10W 10K	R210	ERJ3GEYJ104V	1/16W 100K
R14	ERJ6GEYJ100	1/10W 10	R112	ERJ3GEYJ393V	1/16W 39K	R211	ERJ6GEYJ562V	1/10W 5.6K
R15	ERJ6GEYJ333V	1/10W 33K	R113	ERJ6GEYJ823	1/10W 82K	R212-215	ERJ6GEYJ102V	1/10W 1K
R16	ERJ3GEYJ333V	1/16W 33K	R114	ERJ3GEYJ223V	1/16W 22K	R216	ERJ6GEYJ561V	1/10W 560
R18	ERJ6GEYJ101V	1/10W 100	R115	ERJ6GEYJ564V	1/10W 560K	R219	ERJ6GEYJ473V	1/10W 47K
R20	ERJ6GEYJ224V	1/10W 220K	R116	ERJ3GEYJ333V	1/16W 33K	R221	ERJ3GEYJ821V	1/16W 820
R28	ERJ6GEYJ220	1/10W 22	R117	ERJ3GEYJ184V	1/16W 180K	R222	ERJ3GEYJ103V	1/16W 10K
R29	ERJ3GEYJ220V	1/16W 22	R118	ERJ3GEYJ123V	1/16W 12K	R226-231	ERJ3GEYJ271V	1/16W 270
R36	ERJ3GEYJ221V	1/16W 220	R119	ERJ3GEYJ154V	1/16W 150K	R232	ERJ3GEYJ102V	1/16W 1K
R38	ERJ3GEYJ274V	1/16W 270K	R120	ERJ3GEYJ683V	1/16W 68K	R233	ERJ8GEYJ470V	1/8W 47
R42	ERJ3GEYJ224V	1/16W 220K	R122	ERJ6GEYJ154V	1/10W 150K	R234	ERJ3GEYJ473V	1/16W 47K
R43	ERJ3GEYJ223V	1/16W 22K	R123	ERJ3GEYJ182V	1/16W 1.8K	R235	ERJ3GEYJ122V	1/16W 1.2K
R44	ERJ6GEYJ223V	1/10W 22K	R124	ERJ3GEYJ393V	1/16W 39K	R236, 237	ERJ3GEYJ681V	1/16W 680
R45	ERJ6GEYJ273V	1/10W 27K	R125	ERJ3GEYJ683V	1/16W 68K	R300	ERJ3GEYJ103V	1/16W 10K
R46	ERJ6GEYJ153V	1/10W 15K	R130	ERJ3GEYJ100V	1/16W 10	R301, 302	ERJ3GEYJ183V	1/16W 18K
R47	ERJ3GEYJ104V	1/16W 100K	R135	ERJ6GEYJ221V	1/10W 220	R303, 304	ERJ3GEYJ333V	1/16W 33K
R48	ERJ3GEYJ154V	1/16W 150K	R136	ERJ6GEYJ220	1/10W 22	R309	ERJ3GEYJ303V	1/16W 30K
R49	ERJ12YJ1R2H	1/2W 1.2	R137, 138	ERJ6GEYJ102V	1/10W 1K	R310	ERJ6GEYJ183V	1/10W 18K
R50	ERJ3GEYJ391V	1/16W 390	R139	ERJ6GEYJ223V	1/10W 22K	R315, 316	ERJ6GEYJ122V	1/10W 1.2K
R51, 52	ERJ3GEYJ272V	1/16W 2.7K	R141	ERJ3GEYJ223V	1/16W 22K	R317, 318	ERJ6GEYJ473V	1/10W 47K
R53	ERJ3GEYJ471V	1/16W 470	R143	ERJ6GEYJ561V	1/10W 560	R319, 320	ERJ3GEYJ821V	1/16W 820
R54	ERJ6GEYJ120V	1/10W 12	R144	ERJ6GEYJ821V	1/10W 820	R327, 328	ERJ3GEYJ123V	1/16W 12K
R55	ERJ3GEYJ391V	1/16W 390	R147	ERJ3GEYJ333V	1/16W 33K	R329, 330	ERJ3GEYJ154V	1/16W 150K

Ref. No.	Part No.	Values & Remarks
R331, 332	ERJ3GEYJ120V	1/16W 12
R333, 334	ERJ3GEYJ104V	1/16W 100K
R335, 336	ERJ3GEYJ151V	1/16W 150
R343, 344	ERJ3GEYJ473V	1/16W 47K
R345, 346	ERJ3GEYJ102V	1/16W 1K
R348	ERJ3GEYJ474V	1/16W 470K
R349-351	ERJ3GEYJ471V	1/16W 470
R353	ERJ3GEYJ152V	1/16W 1.5K
R354	ERJ6GEYJ152V	1/10W 1.5K
R355, 356	ERJ3GEYJ100V	1/16W 10
R357, 358	ERJ3GEYJ333V	1/16W 33K
R359, 360	ERJ3GEYJ105V	1/16W 1M
R361, 362	ERJ3GEYJ223V	1/16W 22K
R363, 364	ERJ3GEYJ103V	1/16W 10K
R365, 366	ERJ6GEYJ122V	1/10W 1.2K
R369	ERJ3GEYJ681V	1/16W 680
R370, 371	ERJ3GEYJ222V	1/16W 2.2K
R372, 373	ERJ3GEYJ105V	1/16W 1M
R374, 375	ERJ3GEYJ682V	1/16W 6.8K
R376, 377	ERJ3GEYJ392V	1/16W 3.9K
R378	ERJ6GEYJ102V	1/10W 1K
R379	ERJ3GEYJ102V	1/16W 1K
R380	ERJ6GEYJ104V	1/10W 100K
R381	ERJ3GEYJ104V	1/16W 100K
R382, 383	ERJ3GEYJ563V	1/16W 56K
R384, 385	ERJ3GEYJ333V	1/16W 33K
R386, 387	ERJ3GEYJ103V	1/16W 10K
R388, 389	ERJ3GEYJ223V	1/16W 22K
R390, 391	ERJ3GEYJ273V	1/16W 27K

Ref. No.	Part No.	Values & Remarks
R392, 393	ERJ3GEYJ183V	1/16W 18K
R394, 395	ERJ3GEYJ123V	1/16W 12K
R396	ERJ3GEYJ473V	1/16W 47K
R397	ERJ3GEYJ103V	1/16W 10K
		CAPACITOR(S)
C11, 12	ECEA1AKA470I	10V 47U
C13	SRX01C470GNJ	16V 47U
C14	ECEA0JKA101I	6.3V 100U
C15	ECUV1C105ZFM	16V 1U
C16	ECUV1E103KBN	25V 0.01U
C17	ECEA1EKS4R7I	25V 4.7U
C18	ECUV1H102KBV	50V 1000P
C19	ECUV1E103KBN	25V 0.01U
C20	ECEA1EKS4R7I	25V 4.7U
C21	ECUV1C104KBM	16V 0.1U
C22	ECUV1H331KBN	50V 330P
C23	ECUV1H470KCN	50V 47P
C101	ECUV1C823KBM	16V 0.082U
C102	ECEA1HKNO10I	50V 1U
C103	ECUV1C333KBN	16V 0.033U
C104	ECEA1HKNO10I	50V 1U
C105	ECUV1C333KBN	16V 0.033U
C106	ECEA1HKS010	50V 1U
C107	ECUV1H152KBN	50V 1500P
C108	ECUV1H681KBV	50V 680P
C110	ECUV1C104ZFN	16V 0.1U
C112	ECUV1C104KBM	16V 0.1U

Ref. No.	Part No.	Values & Remarks
C113	ECUV1C223KBN	16V 0.022U
C114	ECUV1C563KBM	16V 0.056U
C115	ECEA1AKA220I	10V 22U
C116	ECUV1C823KBM	16V 0.082U
C117, 118	ECUV1C224KBM	16V 0.22U
C119	ECEA1HKN2R2I	50V 2.2U
C120	ECUV1C223KBN	16V 0.022U
C124	ECEA1HKAR47I	50V 0.47U
C136	ECEA0JKA220	6.3V 22U
C141	ECEA0JKA470I	6.3V 47U
C142	ECEA1CKA100I	16V 10U
C149	ECUV1H222KBN	50V 2200P
C150	ECUV1C104ZFN	16V 0.1U
C201	ECEA1HKA010I	50V 1U
C202	ECUV1C104ZFN	16V 0.1U
C203	ECUV1H270KCN	50V 27P
C204	ECUV1H390KCN	50V 39P
C207	ECUV1H102KBN	50V 1000P
C213	RCST0JY475LE	6.3V 4.7U
C301	ECEA0JPK101I	6.3V 100U
C304	ECEA0JPK101I	6.3V 100U
C311, 312	ECUV1H222KBN	50V 2200P
C313	ECEA1AKA220I	10V 22U
C314	ECEA1AKA470I	10V 47U
C321, 322	ECEA1APK330I	10V 33U
C329, 330	ECEA0GPK221I	4V 220U
C333, 334	ECUV1C104ZFN	16V 0.1U
C335, 336	ECUV1H681KBN	50V 680P
C337, 338	ECUV1C123MBV	16V 0.012U
C340	ECEA0JPK101I	6.3V 100U
C343	ECUV1C104ZFN	16V 0.1U
C346, 347	ECEA1CPK100I	16V 10U
C349, 350	ECUV1H102KBV	50V 1000P
C351	ECUV1C104ZFN	16V 0.1U
C352, 353	ECUV1H332KBV	50V 3300P
C354, 355	ECUV1C333KBN	16V 0.033U
C356, 357	ECEA1HKS2R2I	50V 0.22U
C358, 359	ECUV1C104KBN	16V 0.1U
C362, 363	ECUV1C105ZFM	16V 1U
C364	ECEA0JKA220	6.3V 22U

PACKING

