

TC-U2

*Canadian Model
AEP Model
UK Model
E Model*



STEREO CASSETTE DECK

SAFETY-RELATED COMPONENT WARNING!!

COMPONENTS IDENTIFIED BY SHADING AND MARK  ON THE SCHEMATIC DIAGRAMS, EXPLODED VIEWS AND IN THE PARTS LIST ARE CRITICAL TO SAFE OPERATION. REPLACE THESE COMPONENTS WITH SONY PARTS WHOSE PART NUMBERS APPEAR AS SHOWN IN THIS MANUAL OR IN SUPPLEMENTS PUBLISHED BY SONY.

ATTENTION AU COMPOSANT AYANT RAPPORT À LA SÉCURITÉ!!

LES COMPOSANTS IDENTIFIÉS PAR UN TRAMÉ ET UNE MARQUE  SUR LES DIAGRAMMES SCHÉMATIQUES, LES VUES EXPLODÉES ET LA LISTE DES PIÈCES SONT CRITIQUES POUR LA SÉCURITÉ DE FONCTIONNEMENT. NE REMPLACER CES COMPOSANTS QUE PAR DES PIÈCES SONY DONT LES NUMÉROS SONT DONNÉS DANS CE MANUEL OU DES SUPPLÉMENTS PUBLIÉS PAR SONY.

'Dolby' and the double-D symbol are the trade marks of Dolby Laboratory Inc. Noise reduction system manufactured under license from Dolby Laboratory Inc.

SPECIFICATIONS

GENERAL

Power Requirements:	120V ac, 60 Hz (Canadian model) 240V ac, 50 Hz (UK model) 120, 220V ac, 50 Hz (AEP model) 110, 120, 220, 240V ac, adjustable; 50/60 Hz (E model)
Power Consumption:	10W (Canadian model) 13W (AEP, UK, E model)
Dimensions:	Approx. 410 (w) x 145 (h) x 260 (d) mm 16 1/8 (w) x 5 3/4 (h) x 10 1/4 (d) inches including projecting parts and controls
Weight:	Approx. 5 kg, 11 lb

TAPE RECORDER SECTION

Track:	4-track 2-channel stereo
Fast Forward and Rewind Time:	Approx. 90 seconds with Sony cassette C-60

— Continued on page 2 —

SONY
SERVICE MANUAL

Frequency Response: DOLBY NR OFF
 With Ferri-Chrome cassette
 30-15,000 Hz
 50-13,000 Hz ± 3 dB
 With chromium dioxide cassette
 30-15,000 Hz
 50-13,000 Hz ± 3 dB
 With standard cassette
 30-13,000 Hz

Wow and Flutter: 0.08% WRMS

SN Ratio: DOLBY NR OFF
 With Ferri-Chrome cassette
 55 dB at peak level
 With chromium dioxide cassette
 53 dB at peak level
 DOLBY NR ON
 Improved by 5 dB at 1 kHz,
 10 dB above 5 kHz

Total Harmonic Distortion: 2%

Record Bias Frequency: 80 kHz

Inputs: MIC (phone jacks) 2
 sensitivity 0.25 mV (-70 dB)
 for a low-impedance microphone
 LINE IN (phono jacks) 2
 sensitivity 77.5 mV (-20 dB)
 input impedance 100 kΩ

Outputs: LINE OUTPUT (phono plugs) 2
 output level 0.435 V (-5 dB)
 at load impedance 100 kΩ
 suitable load impedance more than 10 kΩ
 HEADPHONES 1
 output level -26 dB
 at load impedance 8 Ω

REC/PB Jack (DIN): Input impedance less than 10 kΩ
 Output impedance less than 10 kΩ

0 dB = 0.775 V

MODEL IDENTIFICATIONS

- Specification Label -

Canadian model

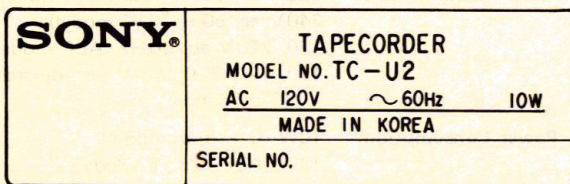

AEP model

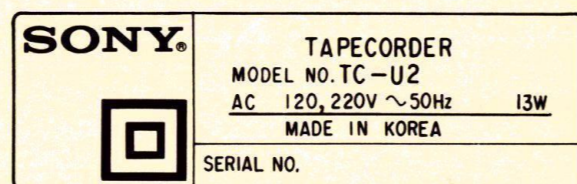

UK model

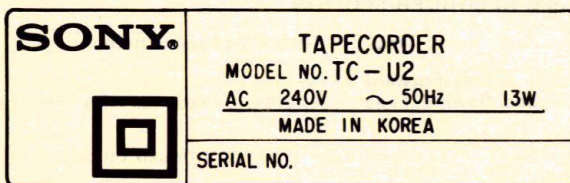

E model

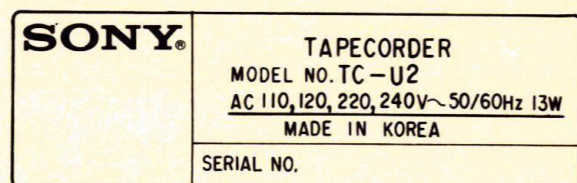

SECTION 1
BLOCK DIAGRAM

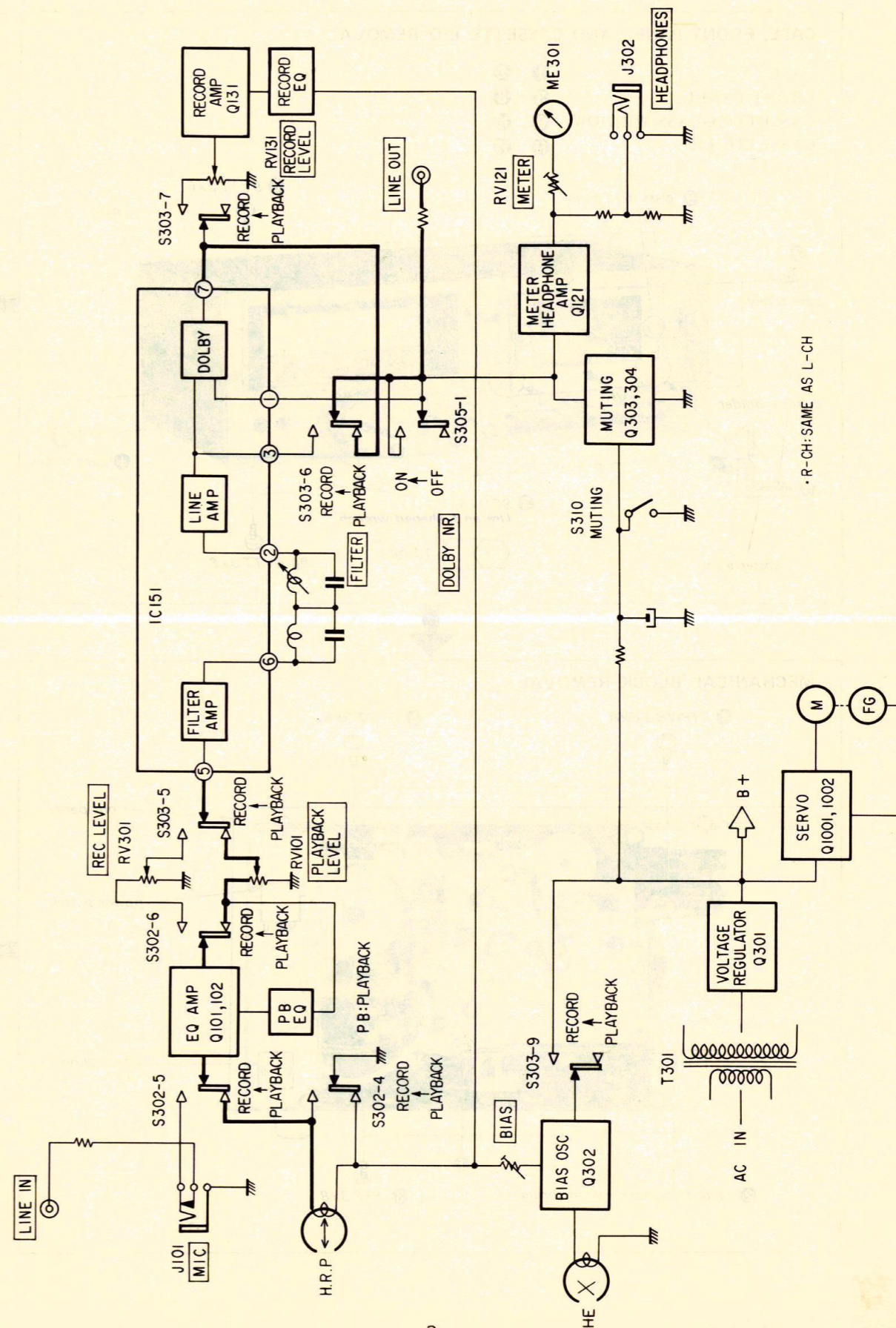

• R-CH: SAME AS L-CH

SECTION 2 DISASSEMBLY

Note: Follow the disassembly procedure in the numerical order given.

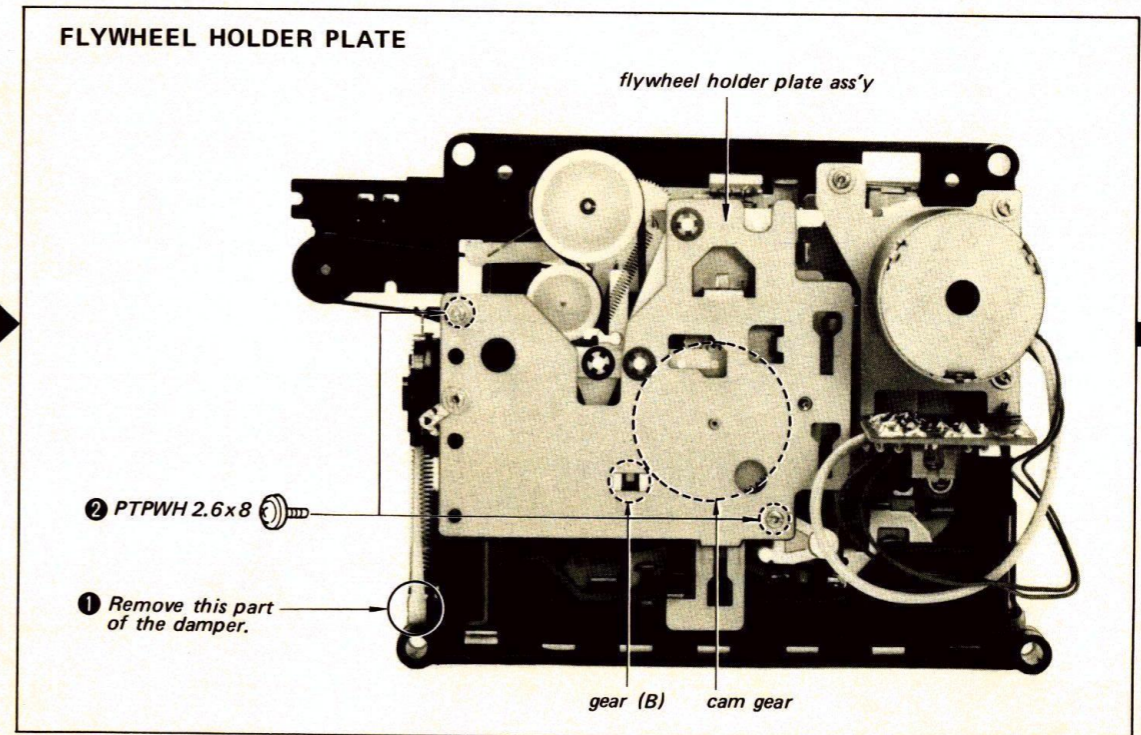
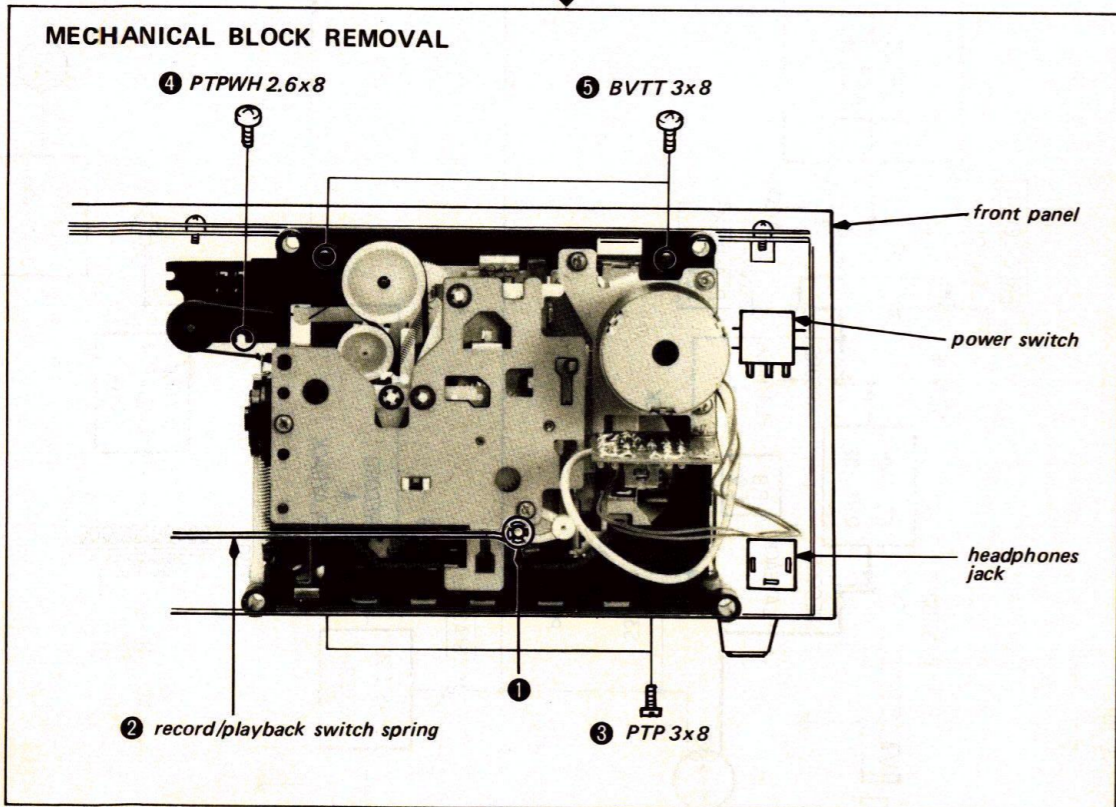
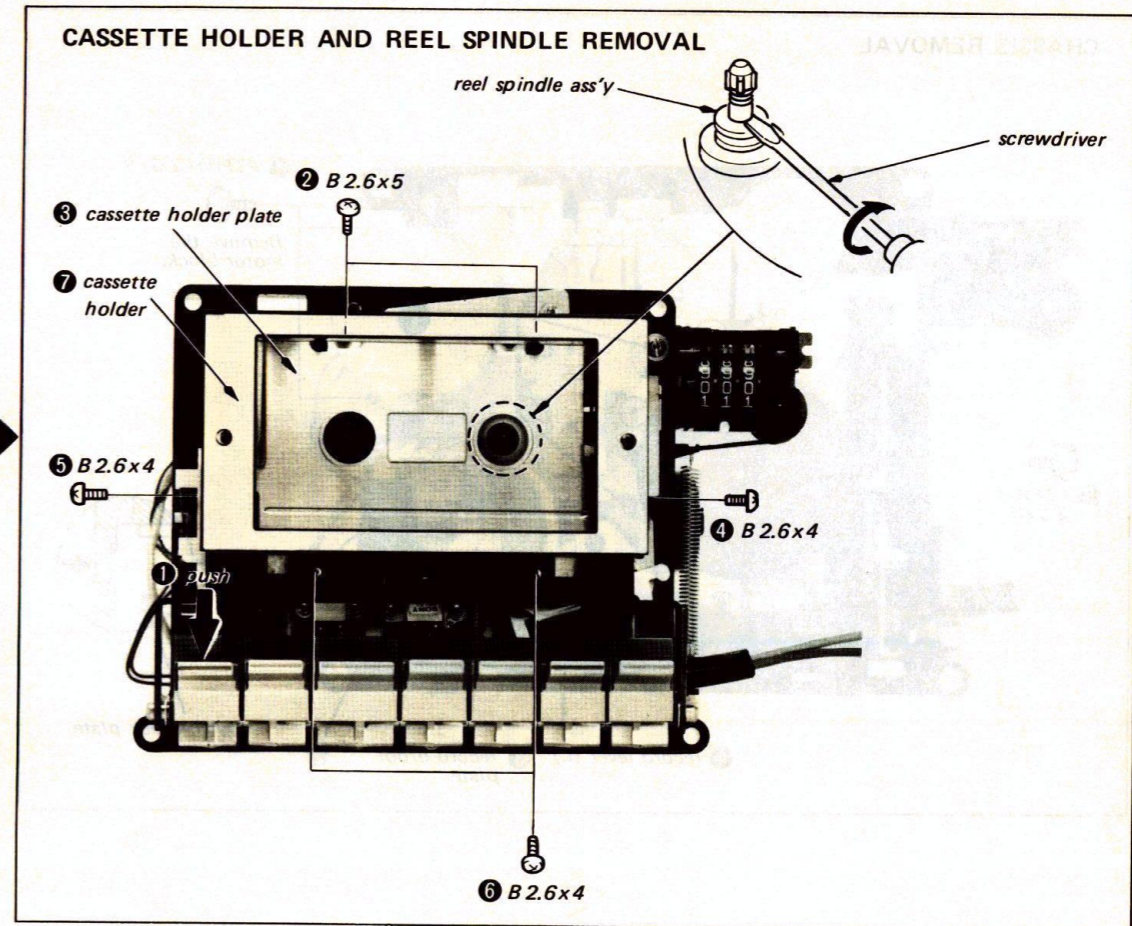
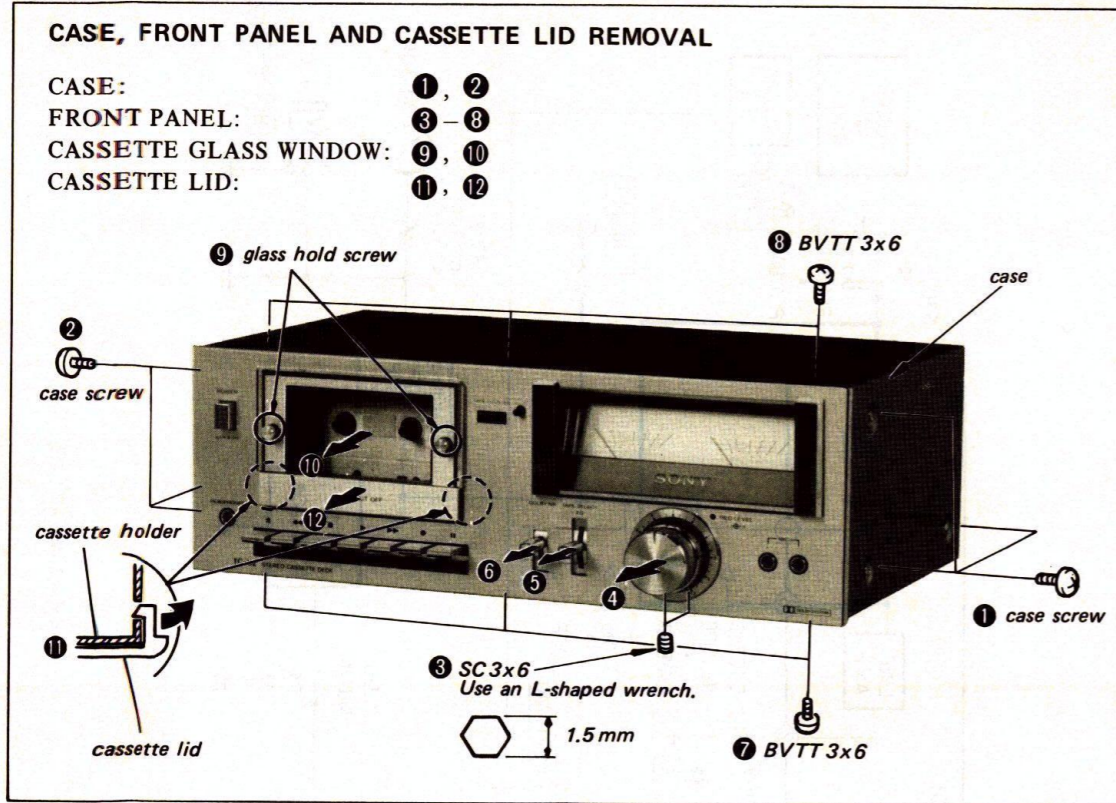

CHASSIS REMOVAL

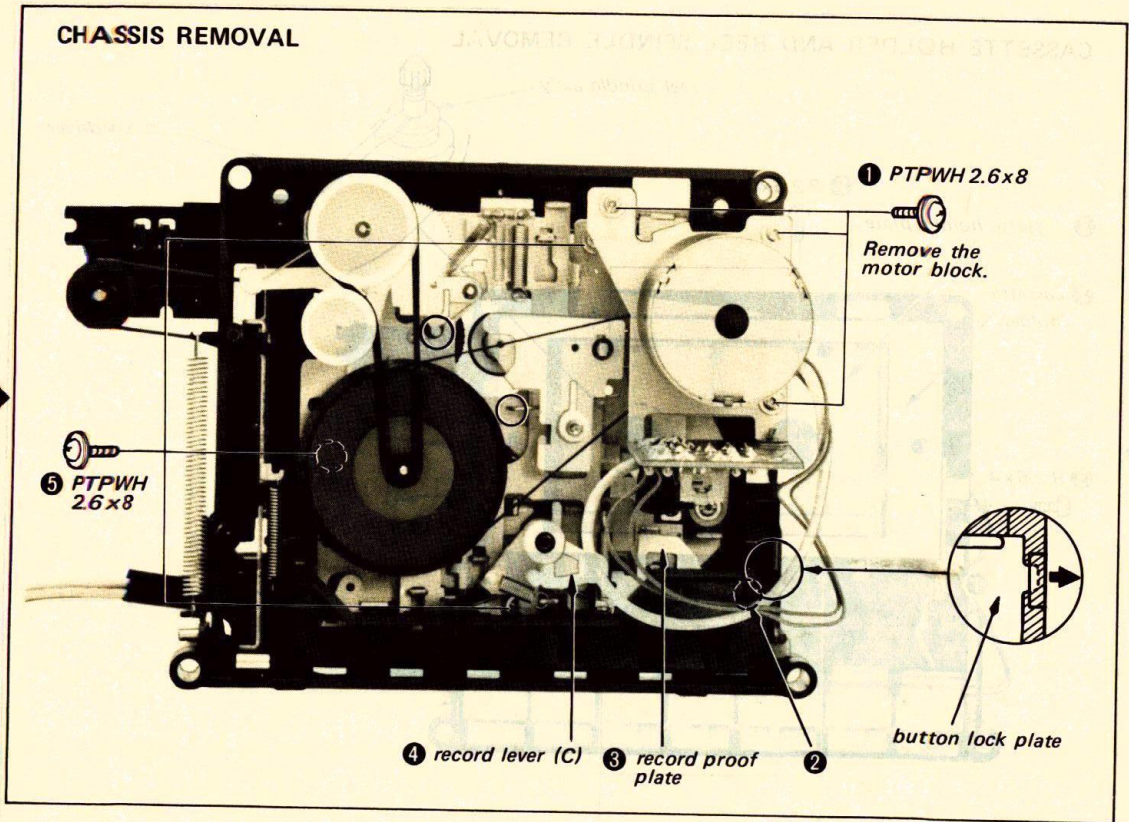

SECTION 3 ADJUSTMENT

3-1. MECHANICAL ADJUSTMENTS

PRECAUTION

- Clean the following parts with a denatured-alcohol-moistened swab:

record/playback head	pinch roller
erase head	rubber belts
capstan	idlers
- Demagnetize the record/playback head with a head demagnetizer.
- Do not use a magnetized screwdriver for the adjustments.
- After the adjustments, apply a suitable locking compound to the parts adjusted.
- The adjustments should be performed with the rated power supply voltage unless otherwise noted.

Torque Adjustment

	Torque meter	Meter reading
forward	CQ-101A, 102A, 103A	25–55 g·cm (0.35–0.77 oz·inch)
fast-forward rewind	CQ-201A	50–90 g·cm (0.69–1.25 oz·inch)

Pinch Roller Pressure Adjustment

– Playback Mode –

- Pull the spring scale.
- Slowly return the pinch roller and read the spring scale just when the pinch roller starts to rotate.
- If necessary, change the hooking position.

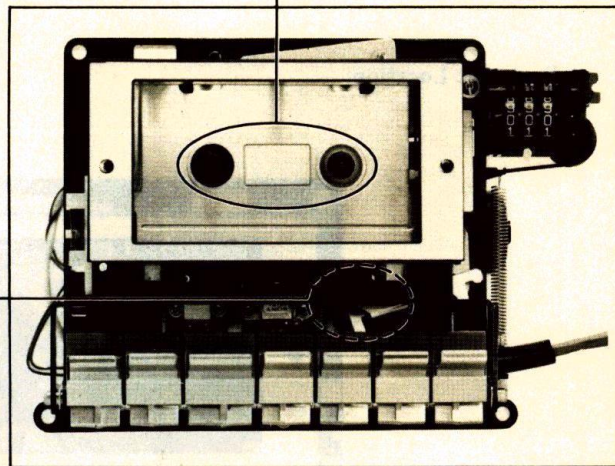
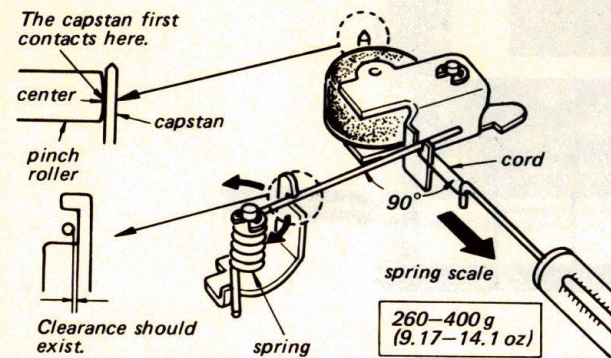

Motor Pulley Height Adjustment

After replacing the motor pulley or the flywheel, this adjustment should be performed.

Procedure:

- Keep the set horizontal.
- Adjust the motor pulley height so that the drive belt is straight without twist.

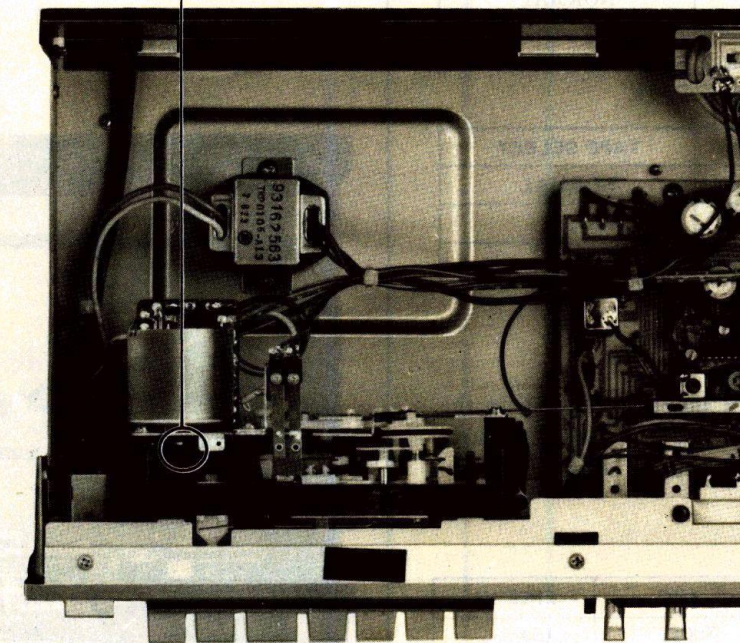
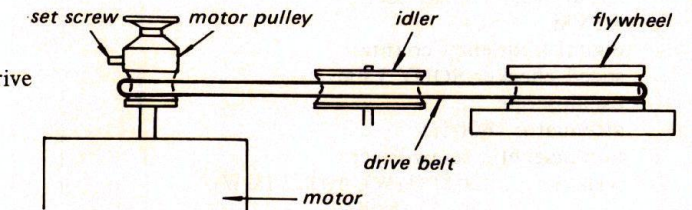

3-2. ELECTRICAL ADJUSTMENTS

Note: The adjustment should be performed in the order given in this service manual. The adjustments should be performed for both L-CH and R-CH.

Test Equipment/Tools Required:

- audio oscillator (af osc)
- VTVM
- digital frequency counter
- speed checker SONY LFM-30
- oscilloscope
- attenuator (600Ω)
- non-magnetic screwdriver
- resistors 600Ω (¼ W), 10 kΩ (¼ W), 100 kΩ (¼ W)
- blank tapes (completely erased with bulk eraser)
- SONY CS-10 (HF), CS-20 (CrO₂), CS-30 (Fe-Cr)
- SONY test tapes
 - P-4-A81S (6.3 kHz, -10 dB)
 - P-4-L81 (333 Hz, 0 dB)
 - WS-48 (3 kHz, 0 dB)

Switch Setting:

Switch	Position
DOLBY NR	OFF
TAPE SELECT	NORMAL

TAPE SELECT switch settings in accordance with tape used are as follows.

TAPE	TAPE SELECT
CS-10	NORMAL
CS-20	CrO ₂
CS-30	Fe-Cr

Standard Record:

Supply the standard input level signal to the LINE IN jack and set the REC LEVEL control to obtain the standard output level signal.

Standard Input Level

	MIC	LINE IN
source impedance	300Ω	10 kΩ
input level	0.77 mV (-60 dB)	0.25 V (-10 dB)

Standard Output Level

	LINE OUT	HEADPHONES
load impedance	100 kΩ	8Ω
output level	0.44 V (-5 dB)	25 mV (-30 dB)

1. Tape Speed Adjustment

Procedure:

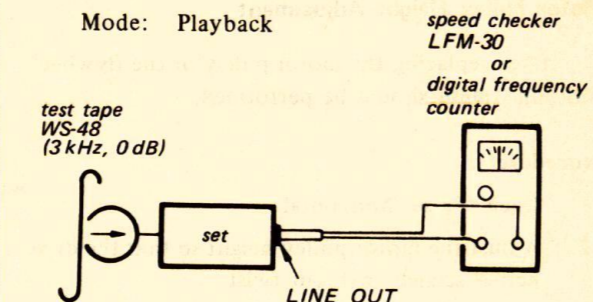

Adjust RV1001 to obtain the specified values below.

Specification:

Speed checker	Digital frequency counter
-2~+3%	2,940-3,090 Hz

Adjustment Location:

- servo amp board -

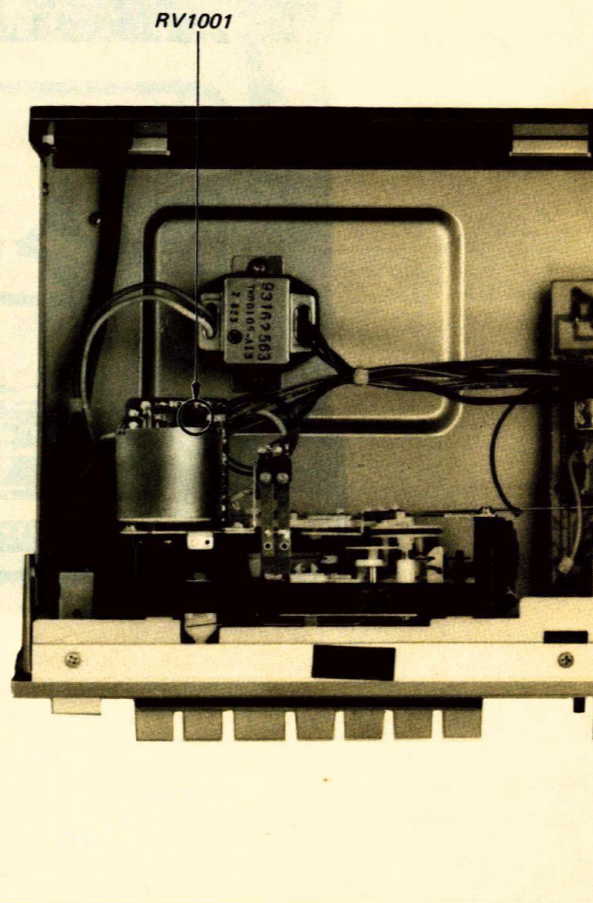

2. Record/playback Head Azimuth Adjustment

Procedure:

1. Mode: Playback

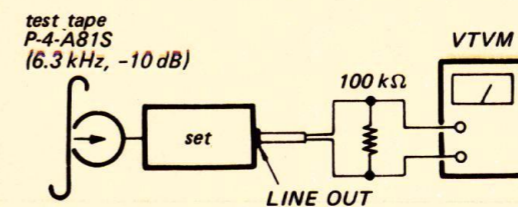

2. Turn the adjustment screw for the maximum level and set it to the mechanical mid position between L-CH and R-CH peak position.

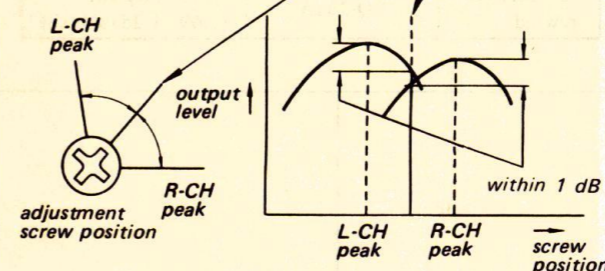

Adjustment Location:

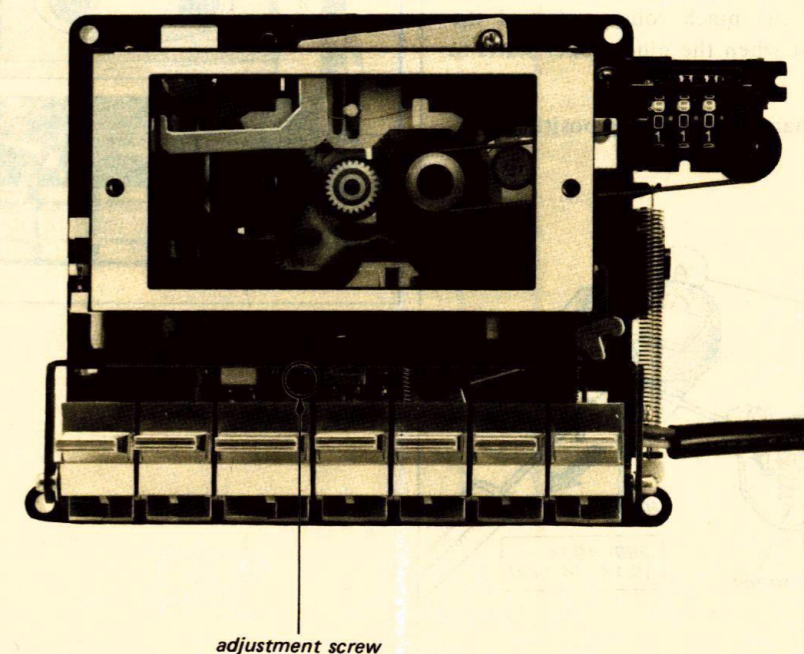

3. Mode: Playback

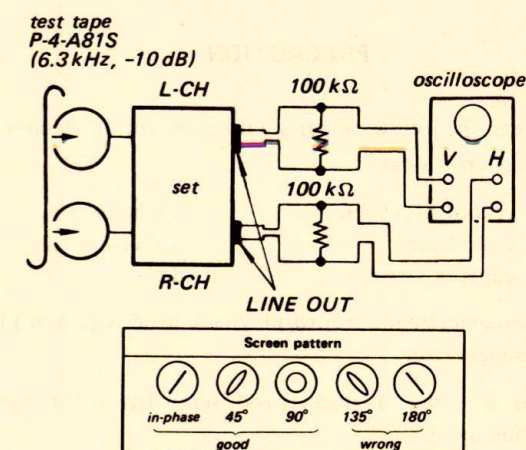

7. MPX Filter Adjustment

Procedure:

Mode: Standard record (See page 9.)
DOLBY NR switch: ON

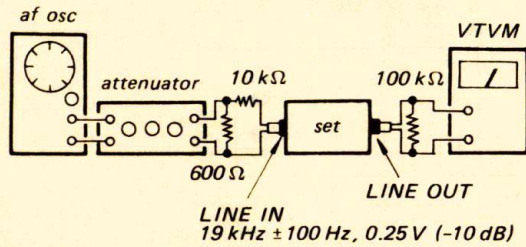

Adjust L152 (L-CH) and L252 (R-CH) for minimum VTVM reading.

4. Record Level Adjustment

Procedure:

1. Mode: Standard record (See page 9.)

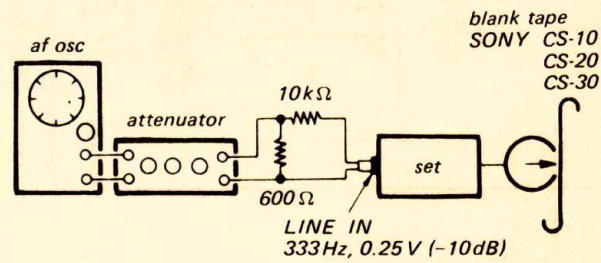

2. Mode: Playback

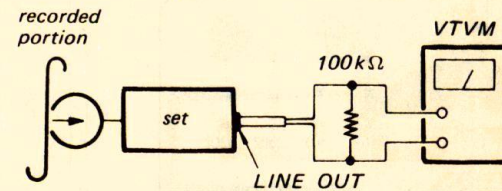

Adjust RV131 (L-CH) and RV231 (R-CH) to obtain the VTVM reading specified below.

Specification:

LINE OUT level: 0.35–0.55 V
(-7 – -3 dB)

3. Playback Level Adjustment

Procedure:

1. Mode: Playback

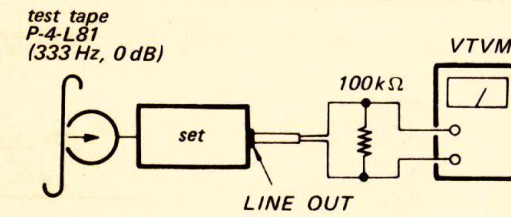

Adjust RV101 (L-CH) and RV201 (R-CH) to obtain the VTVM reading specified below.

2. Assure that the LINE OUT level does not change when the mode is changed from playback to stop several times.

Specification:

LINE OUT level: 0.49–0.62 V
(-4 – -2 dB)

6. Level Meter Calibration

Procedure:

1. Mode: Standard record (See page 9.)

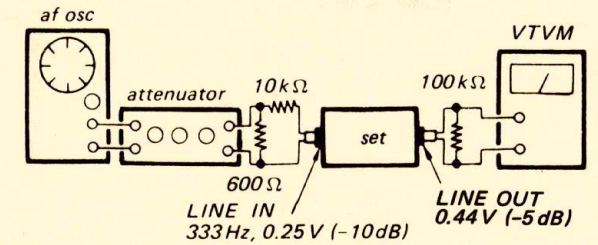

2.

Adjust	Level meter reading: 0VU
RV121 (L-CH) RV221 (R-CH)	

Specification:

When the LINE IN level is adjusted to make 0VU indication, VTVM reading should be 0.44 V (-5 dB).

5. Record Bias Adjustment

Procedure:

1. Mode: Standard record (See page 9.)

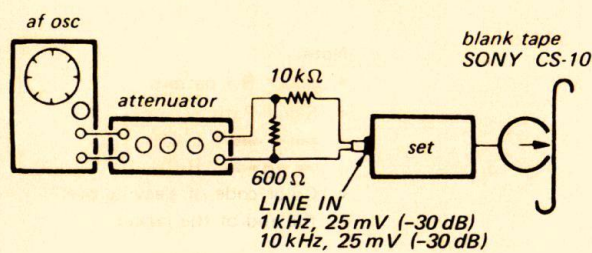

2. Mode: Playback

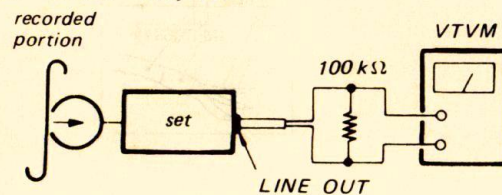

Adjust RV302 (L-CH) and RV303 (R-CH) to make 1 kHz and 10 kHz signal output levels equal.

Level difference between two output levels: 0 dB

Adjustment Location:

– audio amp board –

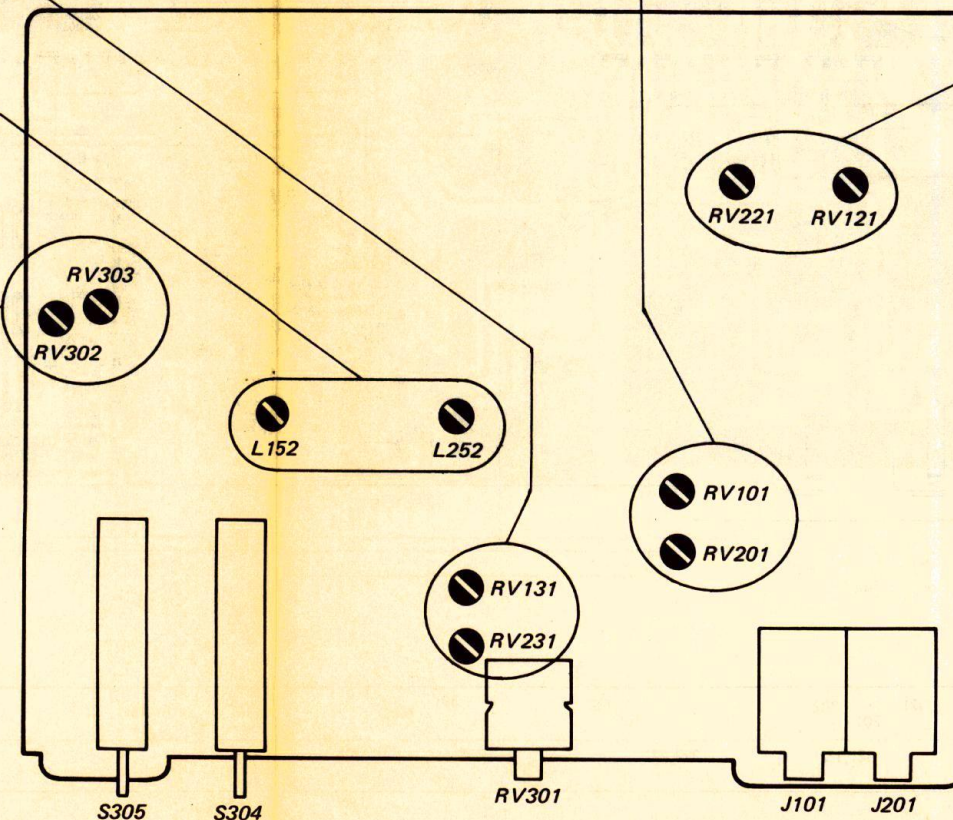

4-1. MOUNTING DIAGRAM - Conductor Side -

SECTION 4
DIAGRAMS

A B C D E F G H

1

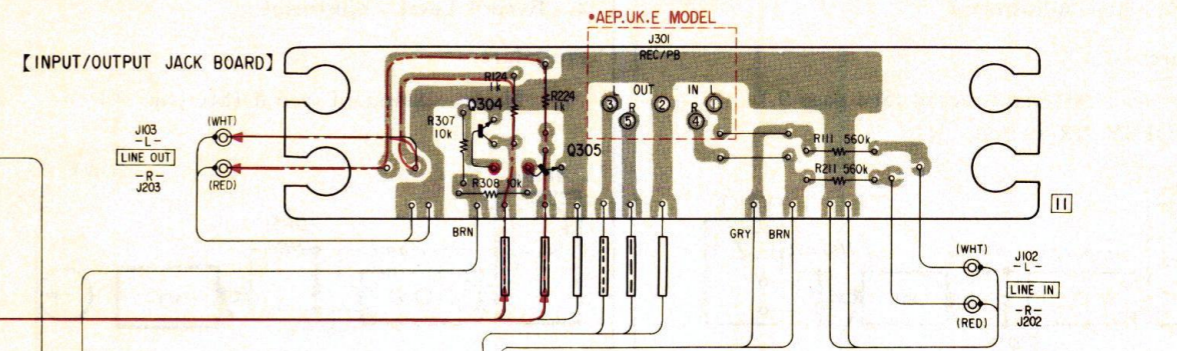
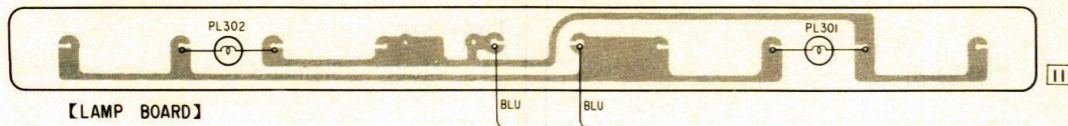

2

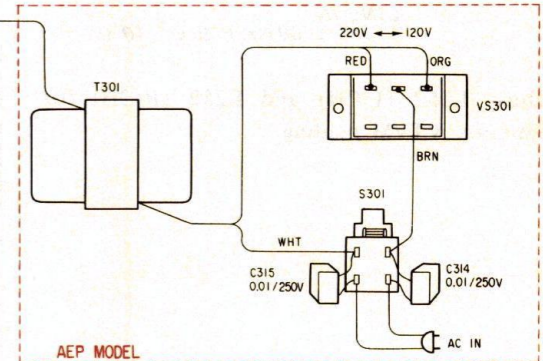
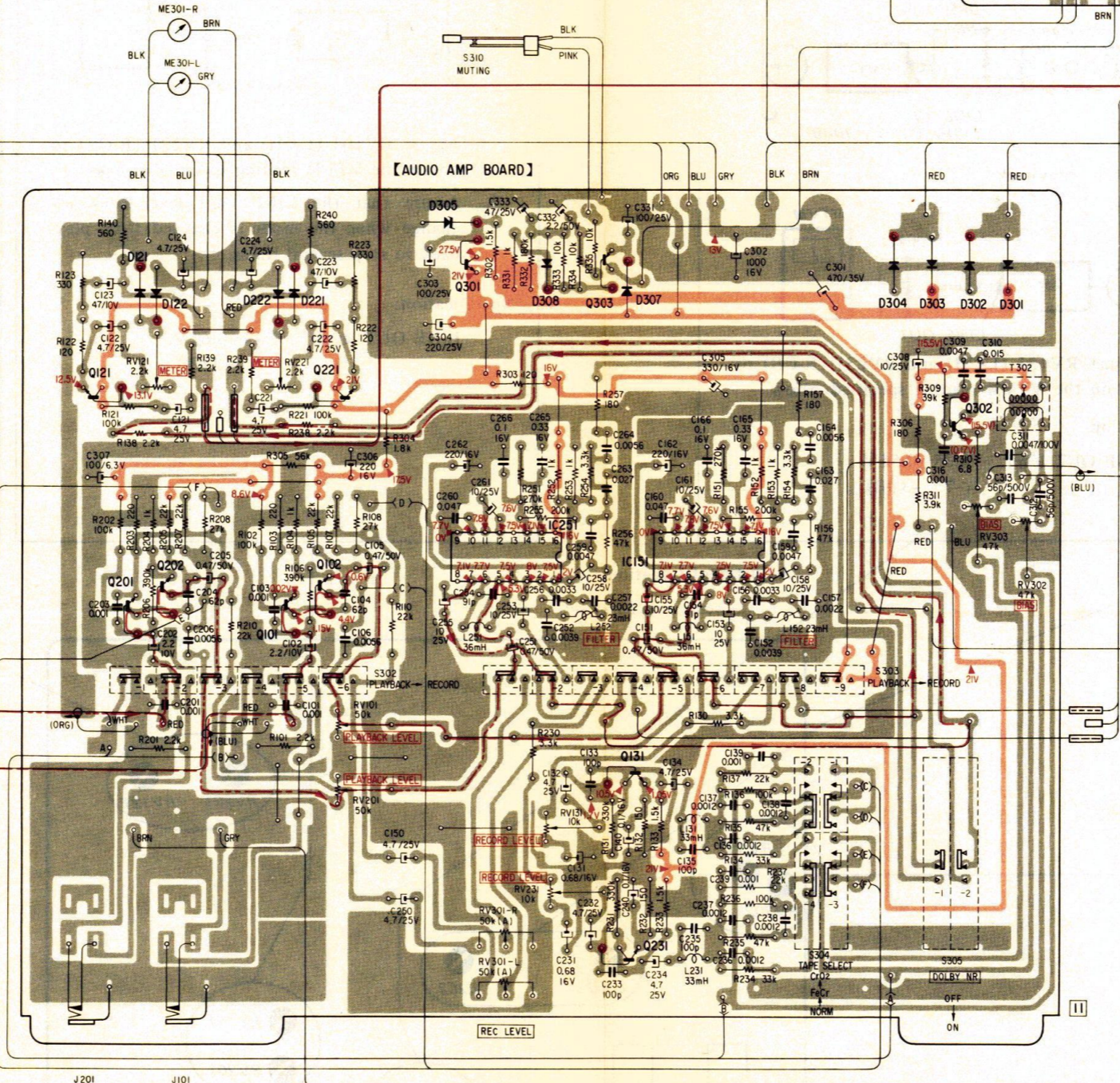
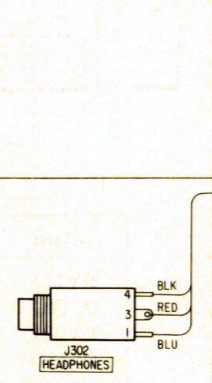

3

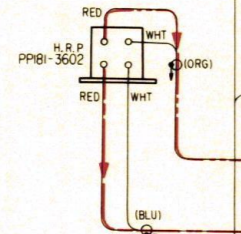

4

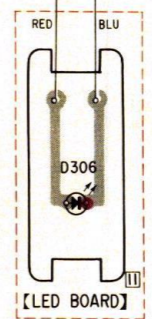
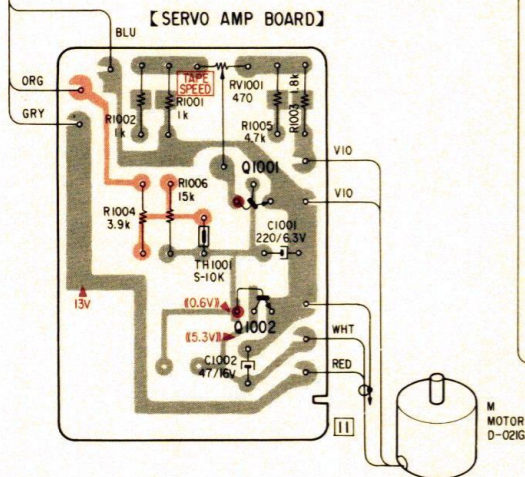

Note:

- : B + pattern
- Signal Path
- L-CH
- R-CH
- Color code of sleeving over the end of the jacket.

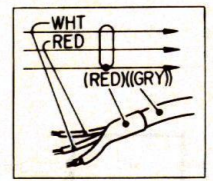

5

Q	IC	1001	1002	121	202	102	301	IC251	303	131	IC151	302	304	305	Q	
D				121, 122	222, 221		305	308	307			304	303	302	301	D

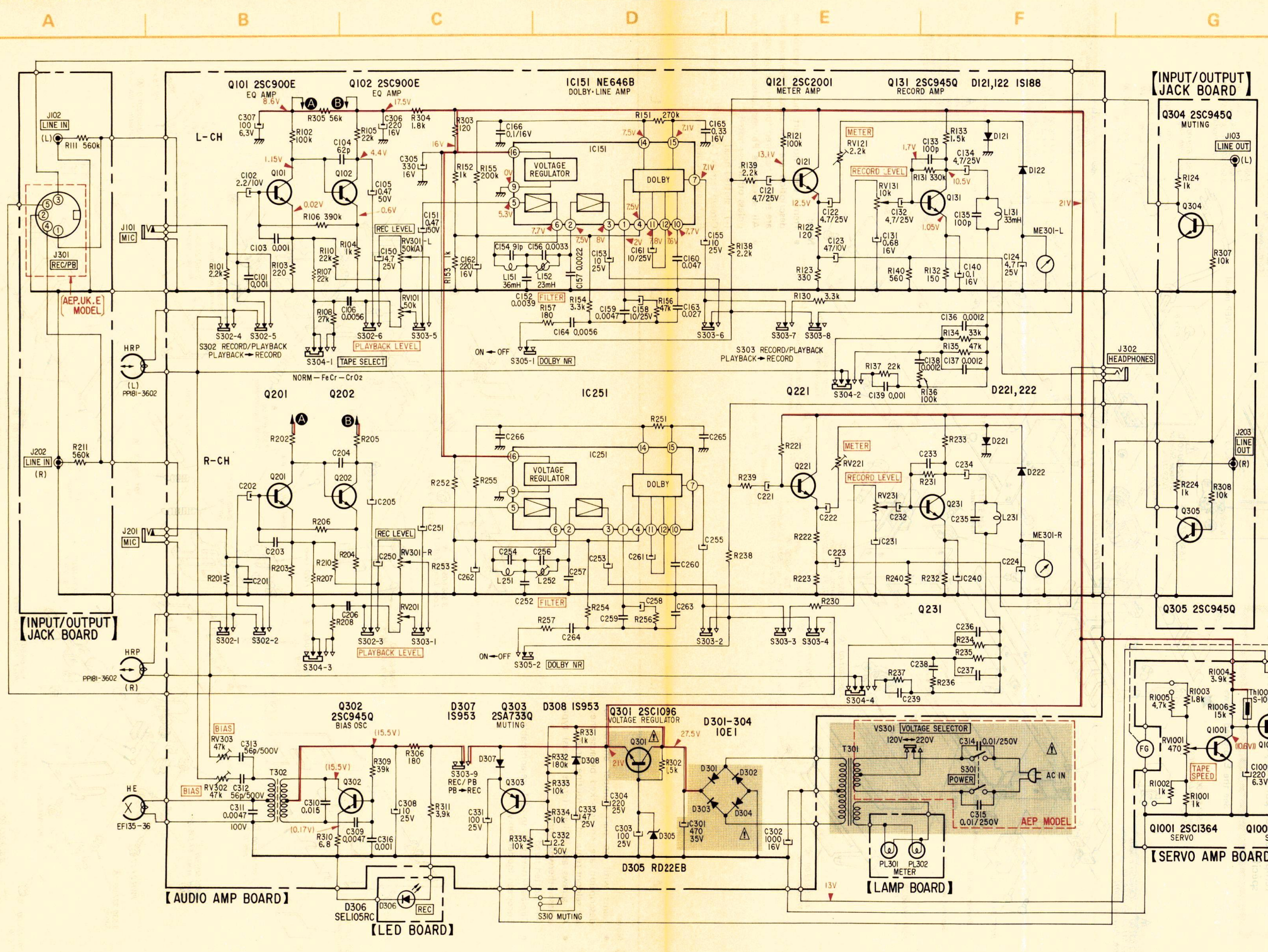

- Note:**
- All capacitors are in μF unless otherwise noted. $\text{pF} = \mu\text{F} \times 10^{-6}$. 50WV or less are not indicated except for electrolytics.
 - All resistors are in ohms, $\frac{1}{4}\text{W}$ unless otherwise noted. $\text{k}\Omega = 1000\Omega$; $\text{M}\Omega = 1000\text{k}\Omega$.
 - Panel designation.
 - Voltages are dc with respect to ground unless otherwise noted.
 - Voltage variations may be noted due to normal production tolerances.
 - Readings are taken under stop conditions with a VOM ($20\text{k}\Omega/\text{V}$).
(V): record condition
((V)): forward condition

Ref. No.	Switch	Position
S301	POWER	OFF
S302, 303	RECORD/PLAYBACK	PB
S304	TAPE SELECT	NORM
S305	DOLBY NR	OFF
S310	MUTING	OFF

Replacement Semiconductors
For replacement, use semiconductors except in ().

- Q101, 102; Q201, 202: 2SC1362 (2SC900E)
- Q101: 2SC1364
- Q301: 2SC1096
- D305: EQB01-22 (RD22EB)
- D121, 122: 1T22AM (1S188)
- D221, 222: 10E2 (10E1)
- D301-304: 1S1555 (1S953)
- Q151, 251: NE646B
- Q101, 102; Q201, 202: 2SC1362 (2SC900E)
- Q201, 202: 2SC1364
- Q301: 2SC1096
- D305: EQB01-22 (RD22EB)
- D121, 122: 1T22AM (1S188)
- D221, 222: 10E2 (10E1)
- D301-304: 1S1555 (1S953)
- Q151, 251: NE646B
- Q101, 102; Q201, 202: 2SC1362 (2SC900E)
- Q201, 202: 2SC1364
- Q301: 2SC1096
- D305: EQB01-22 (RD22EB)
- D121, 122: 1T22AM (1S188)
- D221, 222: 10E2 (10E1)
- D301-304: 1S1555 (1S953)
- Q151, 251: NE646B

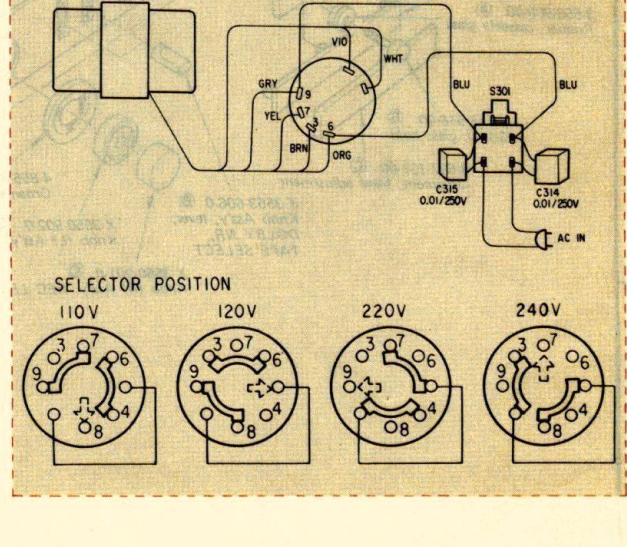
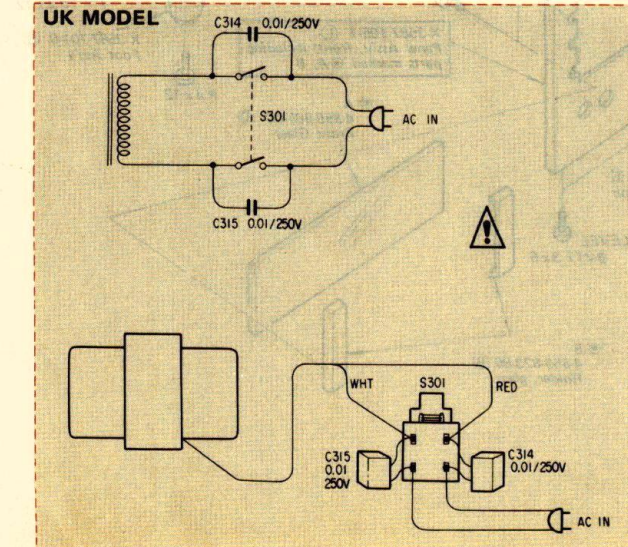
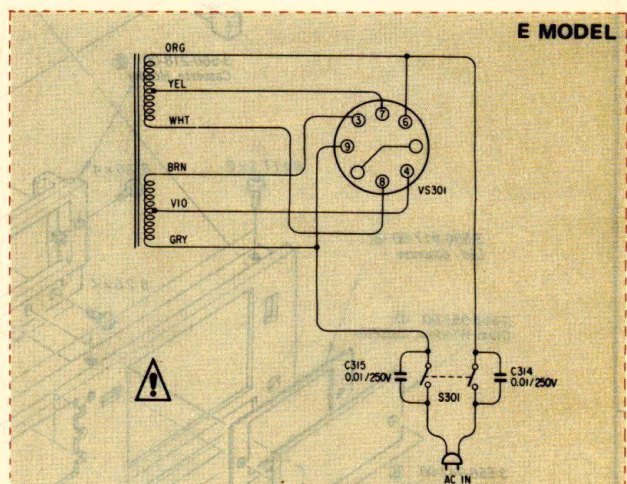
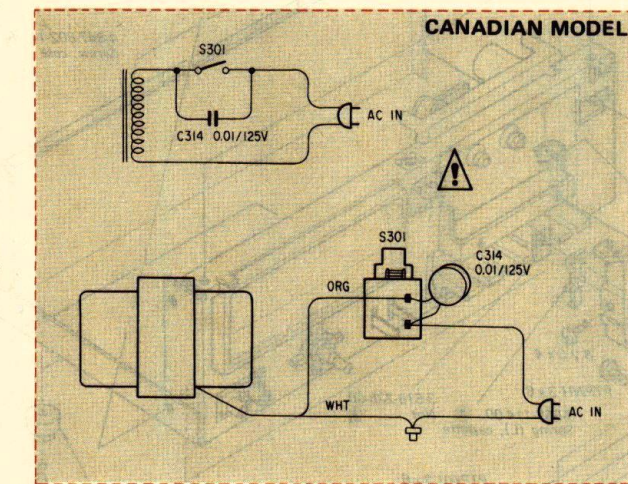

Note: The components identified by shading and mark Δ are critical for safety. Replace only with part number specified.

Note: Les composants identifiés par un trame et une marque Δ sont critiques pour la sécurité. Ne les remplacer que par une pièce portant le numéro spécifié.

A B C D E

(4) Note:

- Items with no part number and/or no description are not stocked because they are seldom required for routine service.
- All screws are Phillips (cross recess) type unless otherwise noted.
- (-) = slotted head
- Circled letters (A) to (Z) are applicable to European models only.

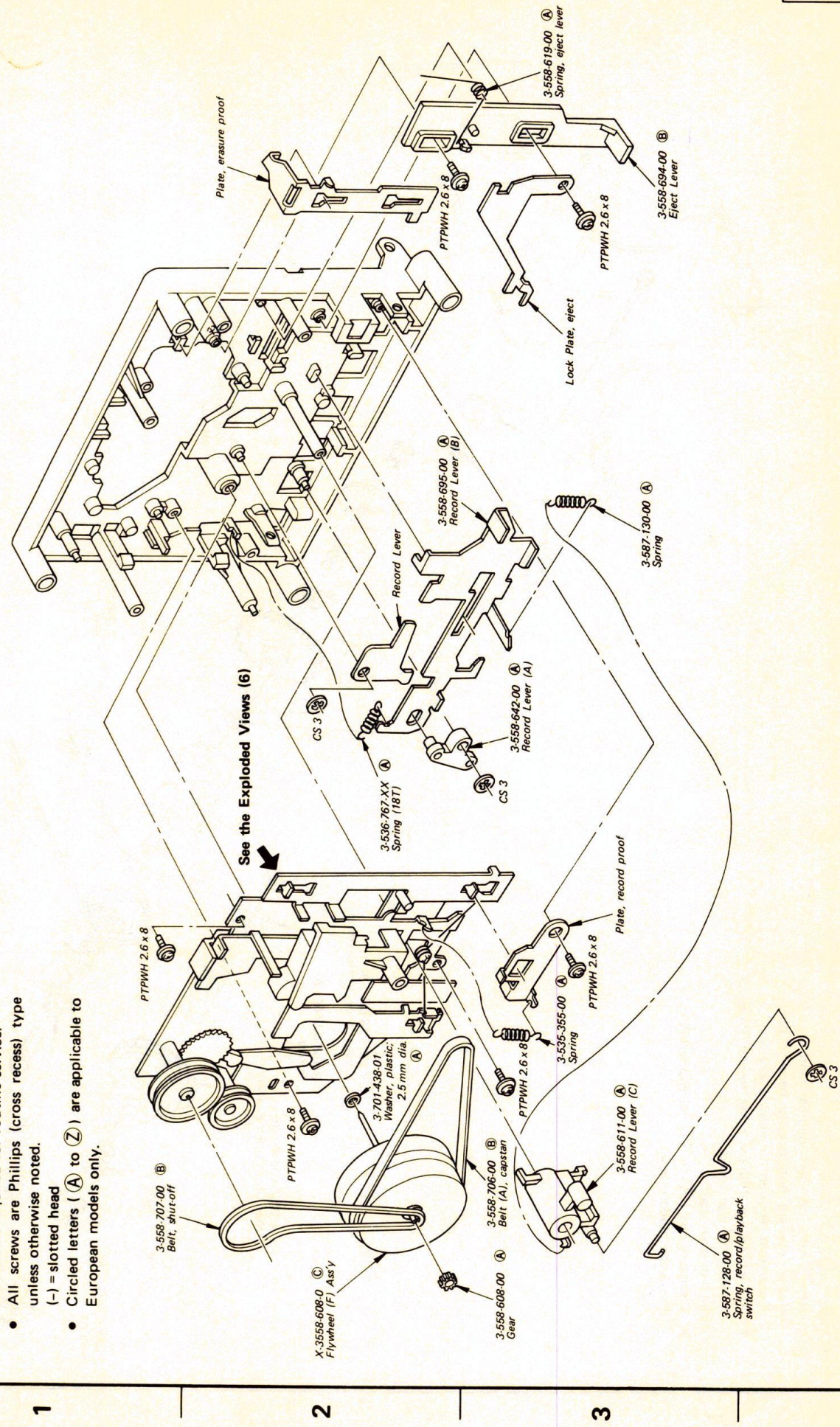

A B C D E

(5) Note:

- Items with no part number and/or no description are not stocked because they are seldom required for routine service.
- All screws are Phillips (cross recess) type unless otherwise noted.
- (-) = slotted head
- Circled letters (A) to (Z) are applicable to European models only.

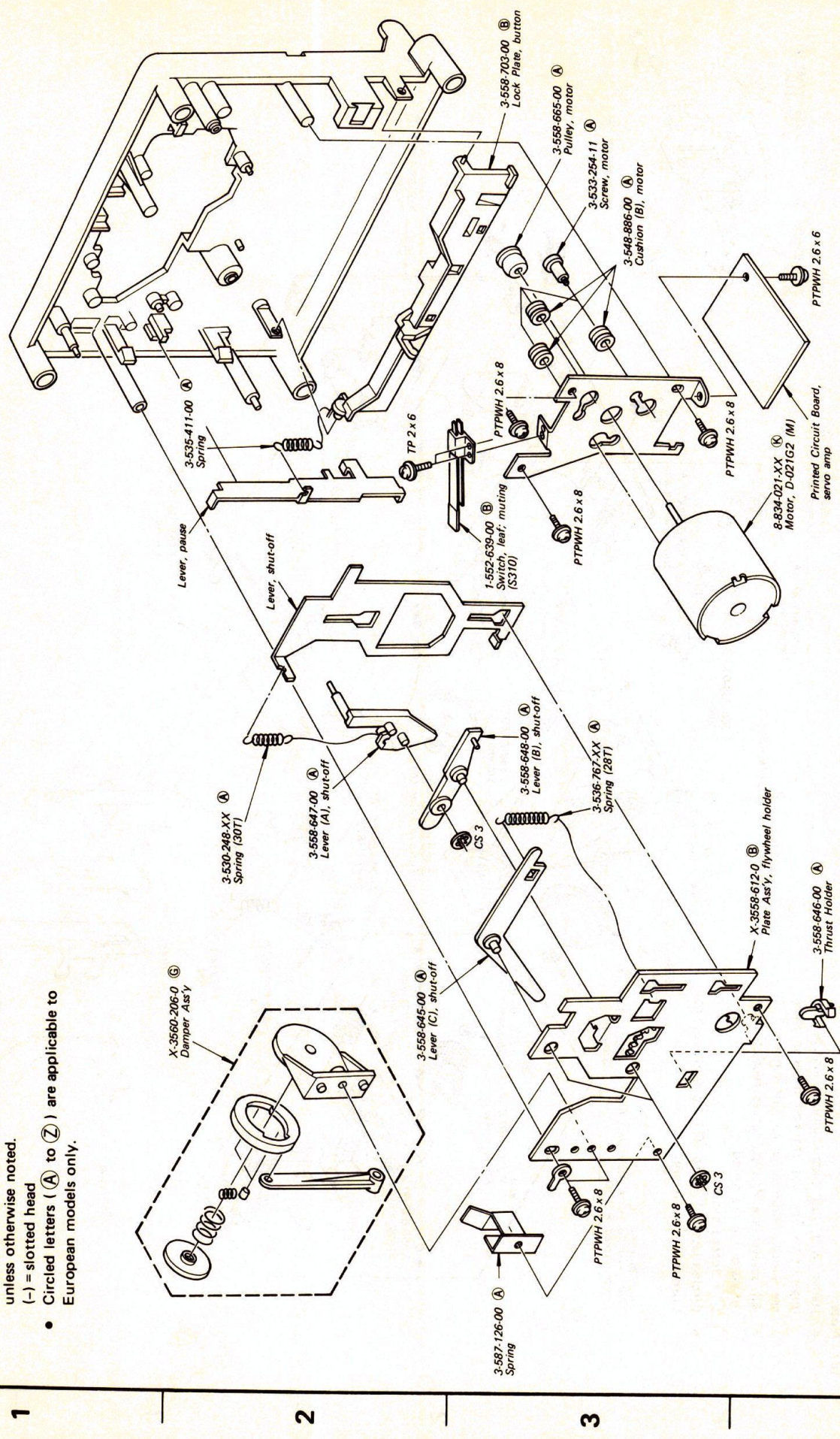

1

2

3

4

1

2

3

4

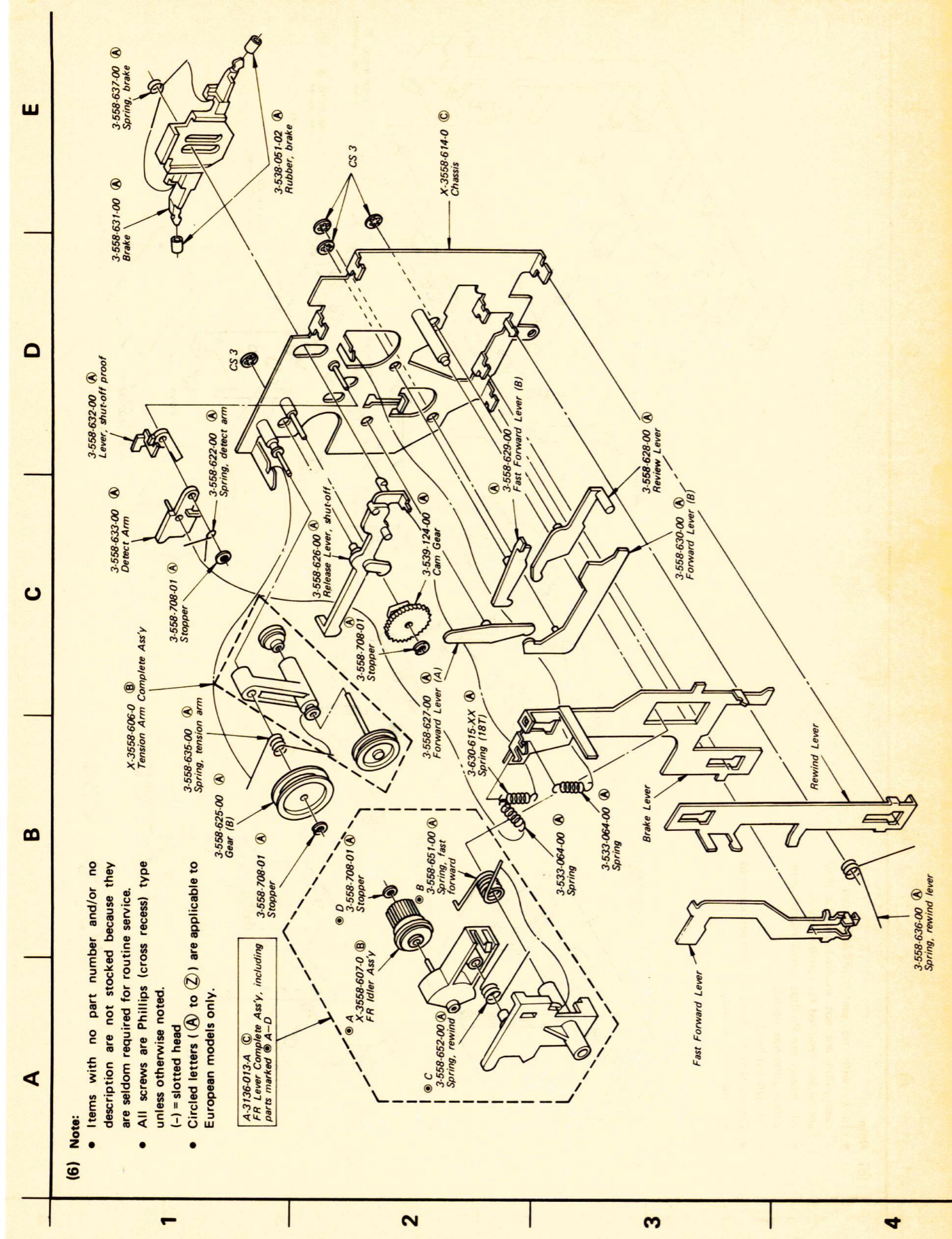

(6) Note:

- Items with no part number and/or no description are not stocked because they are seldom required for routine service.
- All screws are Phillips (cross recess) type unless otherwise noted.
- (-) = slotted head
- Circled letters (A) to (Z) are applicable to European models only.

A-3735-013-A (C) FR Lever Complete Assy, including parts marked A-D

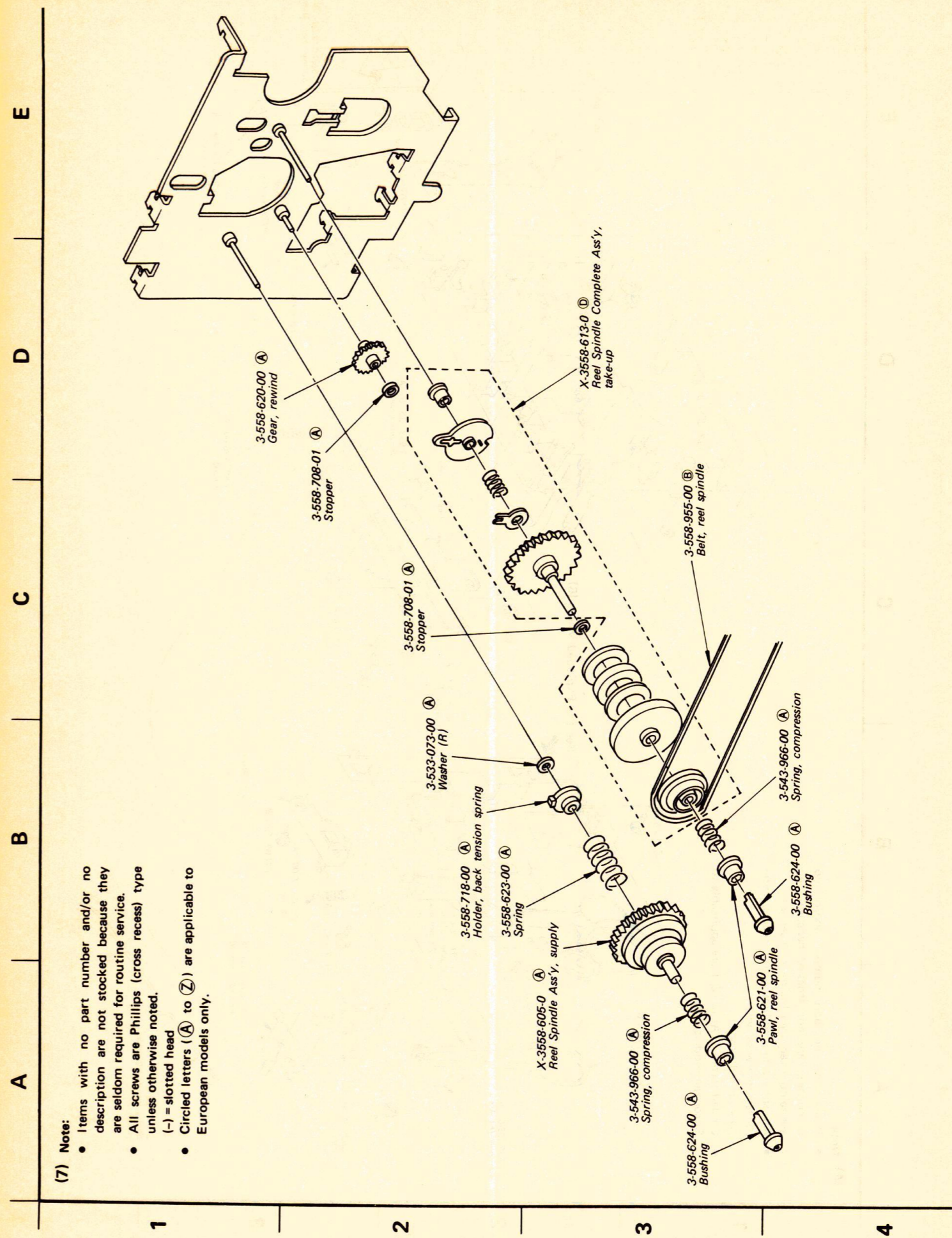

(7) Note:

- Items with no part number and/or no description are not stocked because they are seldom required for routine service.
- All screws are Phillips (cross recess) type unless otherwise noted.
- (-) = slotted head
- Circled letters (A) to (Z) are applicable to European models only.

SECTION 6 ELECTRICAL PARTS LIST

Note: Circled letters (A) to (Z) are applicable to European models only.

Note: Circled letters (A) to (Z) are applicable to European models only.

Ref. No.	Part No.	Description
SEMICONDUCTORS		
Transistors		
⇒ Q101,201		
⇒ Q102,202	8-729-665-47 (B)	2SC1362
Q121,221	8-729-100-13 (B)	2SC2001
⇒ Q131,231	8-729-663-47 (B)	2SC1364
Q301	9-919-380-00 (C)	2SC1096
⇒ Q302	8-729-663-47 (B)	2SC1364
⇒ Q303	8-727-788-00 (B)	2SA678
⇒ Q304,305	8-729-663-47 (B)	2SC1364
Q1001	8-729-663-47 (B)	2SC1364
Q1002	8-729-141-43 (B)	2SD414
ICs		
IC151,251	8-759-906-46	NE646B
Diodes		
⇒ D121,221		
⇒ D122,222	8-719-422-21 (A)	1T22AM
⇒ D301-304	8-719-200-02 (B)	10E2
⇒ D305	8-719-931-22 (B)	EQB01-22
⇒ D306	8-719-301-03 (B)	SEL103R
⇒ D307,308	8-719-815-55 (A)	1S1555
COILS		
L131,231	1-408-155-00 (B)	33 mH, microinductor
L151,251	1-408-157-00 (B)	36 mH, microinductor
L152,252	1-408-156-00 (B)	23 mH, microinductor
TRANSFORMERS		
T301	1-446-218-00 (Power (E model)) 1-446-219-00 (Power (UK model)) 1-446-220-00 (Power (Canadian model)) 1-446-221-00 (Power (AEP model))	
T302	1-405-823-00 (B)	Oscillator

⇒: Due to standardization, interchangeable replacements may be substituted for parts specified in the diagrams.

Ref. No.	Part No.	Description
CAPACITORS		
All capacitors are in μF and ceramic unless otherwise noted. 50WV or less are not indicated except for electrolytics and tantalum. p: μF , elect = electrolytic		
C101,201	1-102-074-11 (A)	0.001
C102,202	1-131-459-11 (A)	2.2 10V tantalum
C103,203	1-102-074-11 (A)	0.001
C104,204	1-101-886-11 (A)	62p
C105,205	1-121-726-11 (A)	0.47 50V elect
C106,206	1-108-573-12 (A)	0.0056 mylar
C121,221	1-121-395-11 (A)	4.7 25V elect
C122,222	1-121-395-11 (A)	4.7 25V elect
C123,223	1-121-352-11 (A)	47 10V elect
C124,224	1-121-395-11 (A)	4.7 25V elect
C131,231	1-131-456-11 (A)	0.68 16V tantalum
C132,232	1-121-395-11 (A)	4.7 25V elect
C133,233	1-102-973-11 (A)	100p
C134,234	1-121-395-11 (A)	4.7 25V elect
C135,235	1-102-973-11 (A)	100p
C136-138		
C236-238	1-108-351-12 (A)	0.0012 mylar
C139,239	1-108-221-12 (A)	0.001 mylar
C140,240	1-131-451-11 (A)	0.1 16V tantalum
C150,250	1-121-395-11 (A)	4.7 25V elect
C151,251	1-121-726-11 (A)	0.47 50V elect
C152,252	1-108-354-12 (A)	0.0039 mylar
C153,253	1-121-398-11 (A)	10 25V elect
C154,254	1-102-972-11 (A)	91p
C155,255	1-121-398-11 (A)	10 25V elect
C156,256	1-108-232-12 (A)	0.0033 mylar
C157,257	1-108-230-12 (A)	0.0022 mylar
C158,258	1-121-398-11 (A)	10 25V elect
C159,259	1-108-234-12 (A)	0.0047 mylar
C160,260	1-108-246-12 (A)	0.047 mylar
C161,261	1-121-398-11 (A)	10 25V elect
C162,262	1-121-421-11 (B)	220 16V elect
C163,263	1-108-359-12 (A)	0.027 mylar

Note: Les composants identifiés par un trame et une marque A sont critiques pour la sécurité. Ne les remplacer que par une pièce portant le numéro spécifié.

Ref. No.	Part No.	Description
C164,264	1-108-355-12 (A)	0.0056 mylar
C165,265	1-131-454-11 (A)	0.33 16V tantalum
C166,266	1-131-451-11 (A)	0.1 16V tantalum
C301	1-121-361-11 (B)	470 35V elect
C302	1-121-245-11 (B)	1000 16V elect
C303	1-121-416-11 (B)	100 25V elect
C304	1-121-422-11 (B)	220 25V elect
C305	1-121-521-11 (B)	330 16V elect
C306	1-121-421-11 (B)	220 16V elect
C307	1-121-413-11 (A)	100 6.3V elect
C308	1-121-398-11 (A)	10 25V elect
C309	1-108-234-12 (A)	0.0047 mylar
C310	1-108-240-12 (A)	0.015 mylar
C311	1-108-373-12 (A)	0.0047 100V mylar
C312,313	1-107-165-11 (A)	56p 500V silvered mica
C314	1-130-151-11 (B)	0.01 125V (Canadian model)
C314,315	1-130-196-11 (D)	0.01 250V polyethylene (AEP, UK, E model)
C316	1-108-221-12 (A)	0.001 mylar
C331	1-121-416-11 (B)	100 25V elect
C332	1-121-450-11 (A)	2.2 50V elect
C333	1-121-410-11 (B)	47 25V elect
C1001	1-121-419-11 (B)	220 6.3V elect
C1002	1-121-409-11 (A)	47 16V elect
RESISTORS		
All resistors are in ohms. Common 1/4W carbon resistors are omitted. Refer to the list on the last page for their part numbers.		
RV101,201	1-226-238-00 (A)	47 k (B), adjustable; playback level
RV121,221	1-226-234-00 (A)	2.2 k (B), adjustable; meter
RV131,231	1-226-236-00 (A)	10 k (B), adjustable; record level
RV301	1-226-380-00 (A)	50 k (A), variable; REC LEVEL
RV302,303	1-226-238-00 (A)	47 k (B), adjustable; bias
RV1001	1-224-641-XX (B)	470 (B), adjustable; tape speed

Note: The components identified by shading and mark A are critical for safety. Replace only with part number specified.

Ref. No.	Part No.	Description
SWITCHES		
S301	1-552-141-12 (E)	Push, POWER (AEP, UK, E model)
S301	1-552-631-00 (B)	Push, POWER (Canadian model)
S302	1-552-632-00 (B)	Slide, record/playback
S303	1-552-634-00 (B)	Slide, record/playback
S304	1-552-633-00 (C)	Lever-slide, TAPE SELECT
S305	1-552-635-00 (C)	Lever-slide, DOLBY NR
S310	1-552-639-00 (B)	Leaf, muting
MISCELLANEOUS		
HE	8-825-506-00 (C)	Head, erase; EF135-36
HRP	8-829-373-00 (K)	Head, record/playback; PP181-3602
J101,201	1-507-554-21 (C)	Jack, MIC
J301	1-507-618-00 (A)	Connector, REC/PB (AEP, UK, E model)
J302	1-507-507-00 (B)	Jack, HEADPHONES
M	8-834-021-XX (K)	Motor, D-021G2
ME301	1-520-377-00 (K)	Meter, VU
PL301,302	1-518-351-00 (B)	Lamp, pilot; meter
VS301	1-552-026-00 (D)	Voltage Selector (E model)
VS301	1-552-630-00 (D)	Voltage Selector (AEP model)
	1-534-777-00 (D)	Cord, power (UK model)
	1-534-817-XX (E)	Cord, power (AEP model)
	1-534-986-XX (C)	Cord, power; parallel blade plug (Canadian, E model)
	1-551-530-11 (D)	Cord, power; euro-plug (E model)
	1-551-629-00 (C)	Cord with Plug

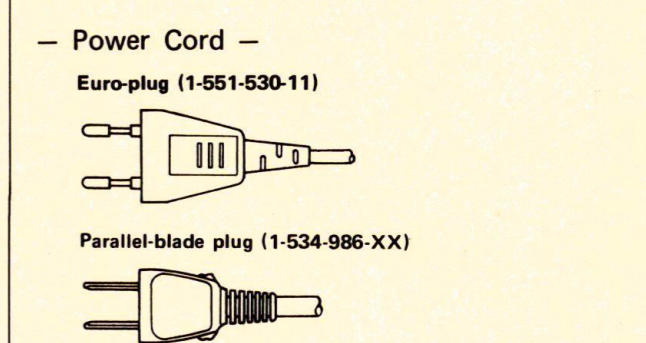

Note: Les composants identifiés par un trame et une marque A sont critiques pour la sécurité. Ne les remplacer que par une pièce portant le numéro spécifié.

Note: Circled letters (A to Z) are applicable to European models only.

1/4 WATT CARBON RESISTORS (A)

Note: Circled letter (A) is applicable to European models only.

ACCESSORIES & PACKING MATERIALS

Part No.	Description
X-3701-105-0	(A) Tips Ass'y, head cleaning
3-587-101-00	(B) Cushion
3-587-112-00	Carton (Canadian model)
3-587-113-00	(D) Carton (AEP, UK, E model)
3-701-630-00	(A) Bag, polyethylene
3-770-562-11	(D) Manual, instruction
4-855-809-00	(B) Bag, polyethylene

Ω	Part No.	Ω	Part No.	Ω	Part No.	Ω	Part No.	Ω	Part No.	Ω	Part No.	Ω	Part No.
1.0	1-244-601-11	10	1-244-625-11	100	1-244-649-11	1.0k	1-244-673-11	10k	1-244-697-11	100k	1-244-721-11	1.0M	1-244-745-11
1.1	1-244-602-11	11	1-244-626-11	110	1-244-650-11	1.1k	1-244-674-11	11k	1-244-698-11	110k	1-244-722-11	1.1M	1-244-746-11
1.2	1-244-603-11	12	1-244-627-11	120	1-244-651-11	1.2k	1-244-675-11	12k	1-244-699-11	120k	1-244-723-11	1.2M	1-244-747-11
1.3	1-244-604-11	13	1-244-628-11	130	1-244-652-11	1.3k	1-244-676-11	13k	1-244-700-11	130k	1-244-724-11	1.3M	1-244-748-11
1.5	1-244-605-11	15	1-244-629-11	150	1-244-653-11	1.5k	1-244-677-11	15k	1-244-701-11	150k	1-244-725-11	1.5M	1-244-749-11
1.6	1-244-606-11	16	1-244-630-11	160	1-244-654-11	1.6k	1-244-678-11	16k	1-244-702-11	160k	1-244-726-11	1.6M	1-244-750-11
1.8	1-244-607-11	18	1-244-631-11	180	1-244-655-11	1.8k	1-244-679-11	18k	1-244-703-11	180k	1-244-727-11	1.8M	1-244-751-11
2.0	1-244-608-11	20	1-244-632-11	200	1-244-656-11	2.0k	1-244-680-11	20k	1-244-704-11	200k	1-244-728-11	2.0M	1-244-752-11
2.2	1-244-609-11	22	1-244-633-11	220	1-244-657-11	2.2k	1-244-681-11	22k	1-244-705-11	220k	1-244-729-11	2.2M	1-244-753-11
2.4	1-244-610-11	24	1-244-634-11	240	1-244-658-11	2.4k	1-244-682-11	24k	1-244-706-11	240k	1-244-730-11	2.4M	1-244-754-11
2.7	1-244-611-11	27	1-244-635-11	270	1-244-659-11	2.7k	1-244-683-11	27k	1-244-707-11	270k	1-244-731-11	2.7M	1-244-755-11
3.0	1-244-612-11	30	1-244-636-11	300	1-244-660-11	3.0k	1-244-684-11	30k	1-244-708-11	300k	1-244-732-11	3.0M	1-244-756-11
3.3	1-244-613-11	33	1-244-637-11	330	1-244-661-11	3.3k	1-244-685-11	33k	1-244-709-11	330k	1-244-733-11	3.3M	1-244-757-11
3.6	1-244-614-11	36	1-244-638-11	360	1-244-662-11	3.6k	1-244-686-11	36k	1-244-710-11	360k	1-244-734-11	3.6M	1-244-758-11
3.9	1-244-615-11	39	1-244-639-11	390	1-244-663-11	3.9k	1-244-687-11	39k	1-244-711-11	390k	1-244-735-11	3.9M	1-244-759-11
4.3	1-244-616-11	43	1-244-640-11	430	1-244-664-11	4.3k	1-244-688-11	43k	1-244-712-11	430k	1-244-736-11	4.3M	1-244-760-11
4.7	1-244-617-11	47	1-244-641-11	470	1-244-665-11	4.7k	1-244-689-11	47k	1-244-713-11	470k	1-244-737-11	4.7M	1-244-761-11
5.1	1-244-618-11	51	1-244-642-11	510	1-244-666-11	5.1k	1-244-690-11	51k	1-244-714-11	510k	1-244-738-11	5.1M	1-244-762-11
5.6	1-244-619-11	56	1-244-643-11	560	1-244-667-11	5.6k	1-244-691-11	56k	1-244-715-11	560k	1-244-739-11		
6.2	1-244-620-11	62	1-244-644-11	620	1-244-668-11	6.2k	1-244-692-11	62k	1-244-716-11	620k	1-244-740-11		
6.8	1-244-621-11	68	1-244-645-11	680	1-244-669-11	6.8k	1-244-693-11	68k	1-244-717-11	680k	1-244-741-11		
7.5	1-244-622-11	75	1-244-646-11	750	1-244-670-11	7.5k	1-244-694-11	75k	1-244-718-11	750k	1-244-742-11		
8.2	1-244-623-11	82	1-244-647-11	820	1-244-671-11	8.2k	1-244-695-11	82k	1-244-719-11	820k	1-244-743-11		
9.1	1-244-624-11	91	1-244-648-11	910	1-244-672-11	9.1k	1-244-696-11	91k	1-244-720-11	910k	1-244-744-11		

HARDWARE NOMENCLATURE

Screw:

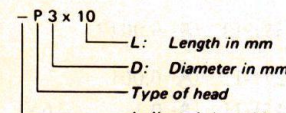

Unless otherwise indicated, it means cross-recessed head (Phillips type).

Nut, Washer, Retaining ring:

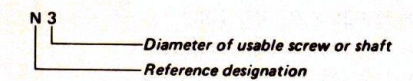

Reference Designation	Shape	Description	Remarks
SCREWS			
P		pan-head screw	binding-head (B) screw for replacement
PWH		pan-head screw with washer face	binding-head (B) screw and flat washer for replacement
PS PSP		pan-head screw with spring washer	binding-head (B) screw and spring washer for replacement
PSW PSPW		pan-head screw with spring and flat washers	binding-head (B) screw and spring and flat washers for replacement
R		round-head screw	binding-head (B) screw for replacement
K		flat-countersunk-head screw	
RK		oval-countersunk-head screw	
B		binding-head screw	
T		truss-head screw	binding-head (B) screw for replacement
F		flat-fillister-head screw	
RF		fillister-head screw	
BV		braizer-head screw	

Reference Designation	Shape	Description	Remarks
SELF-TAPPING SCREWS			
TA		self-tapping screw	ex: TA, P 3 x 10
PTP		pan-head self-tapping screw	binding-head self-tapping (TA, B) screw for replacement
PTPWH		pan-head self-tapping screw with washer face	binding-head self-tapping (TA, B) screw and flat washer for replacement
PTTWH		pan-head thread-rolling screw with washer face	binding-head (B) screw and flat washer for replacement
SET SCREWS			
SC		set screw	
SC		hexagon-socket set screw	ex: SC 2.6 x 4, hexagon socket
NUT			
N		nut	
WASHERS			
W		flat washer	
SW		spring washer	
LW		internal-tooth lock washer	ex: LW3, internal
LW		external-tooth lock washer	ex: LW3, external
RETAINING RINGS			
E		retaining ring	
G		grip-type retaining ring	

Sony Corporation

© 1978

— 28 —