

Free service manuals
Gratis schema's

Digitized by

www.freesevicemanuals.info

AEP Model

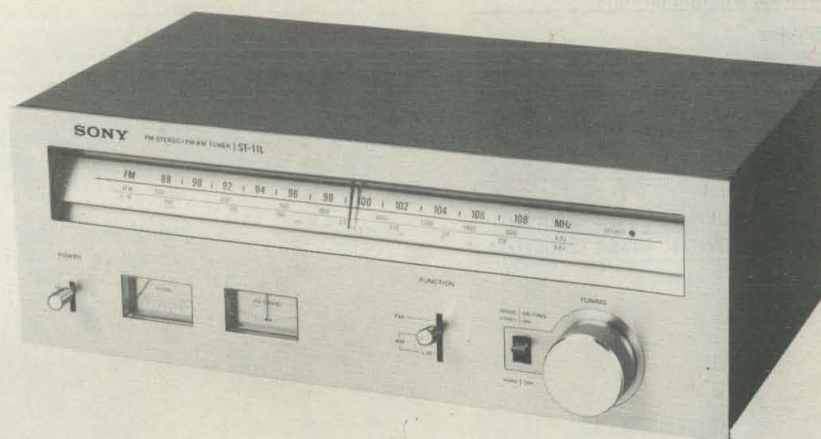

FM STEREO/FM-AM TUNER

SPECIFICATIONS

GENERAL

Power Requirements: 110, 120, 220 or 240V ac adjustable, 50/60Hz.

Power Consumption: 9W

Dimensions: Approx.
406(w) x 145(h) x 245(d) mm
16(w) x 5½(h) x 9¾(d) inches
incl. projecting parts and controls

Weight: Approx 3.6 kg, 7 lb 15 oz (net)
4.9 kg, 10 lb 13 oz
(with shipping carton)

Harmonic Distortion: At 100Hz
0.2% (MONO)
0.3% (STEREO)

At 1kHz
0.2% (MONO)
0.3% (STEREO)

At 10kHz
0.2% (MONO)
0.5% (STEREO)

IM Distortion: 0.2% (MONO)
0.3% (STEREO)

Separation: 35dB at 100Hz
45dB at 1kHz
35dB at 10kHz

Frequency Response: 30Hz–15kHz ^{+0.5}/_{-2.0} dB

Alternate Channel Selectivity: 55dB

Capture Ratio: 1.0dB

AM Suppression Ratio: 50dB

Image Response Ratio: 45dB

IF Response Ratio: 90dB

Spurious Response Ratio: 75dB

RF Intermodulation: 60dB

Sub-carrier Product Ratio: 30dB

Muting Threshold: Approx. 3µV

Output Level: 750mV, 5kΩ

(at 1kHz, 100% modulation)

FM SECTION

Tuning Range: 87.5–108MHz

Antenna Terminals: 300Ω, balanced
75Ω, unbalanced

Intermediate Frequency: 10.7MHz

Sensitivity at 50dB Quieting: 4.0µV (MONO), new IHF 17.3dBf
45µV (STEREO), new IHF 38.3dBf

Usable Sensitivity: IHF 1.8µV, new IHF 10.3dBf

S/N Ratio: 70dB (MONO)
68dB (STEREO)

— Continued on page 2 —

SAFETY-RELATED COMPONENT WARNING!!

COMPONENTS IDENTIFIED BY SHADING ON THE SCHEMATIC DIAGRAMS AND IN THE PARTS LIST ARE CRITICAL TO SAFE OPERATION. REPLACE THESE COMPONENTS WITH SONY PARTS WHOSE PART NUMBERS APPEAR AS SHOWN IN THIS MANUAL OR IN SUPPLEMENTS PUBLISHED BY SONY.

SONY
SERVICE MANUAL

MW, LW SECTION

	MW	LW
Tuning Range	530-1,605kHz	150-350kHz
Antenna	Built-in ferrite rod antenna External antenna terminal	
Intermediate Frequency	455kHz	
Usable Sensitivity	48dB/m, built-in antenna(1,000kHz)	55dB/m, built-in antenna(240kHz)
S/N Ratio	50dB (50mV/m)	48dB (50mV/m)
Harmonic Distortion	0.5% (50mV/m, 400Hz)	
Selectivity	45dB (10kHz)	
Image Response Ratio	40dB (1,000kHz)	45dB (240kHz)
IF Response Ratio	35dB (1,000kHz)	35dB (240kHz)

SECTION 1 OUTLINE

1-1. BLOCK DIAGRAM

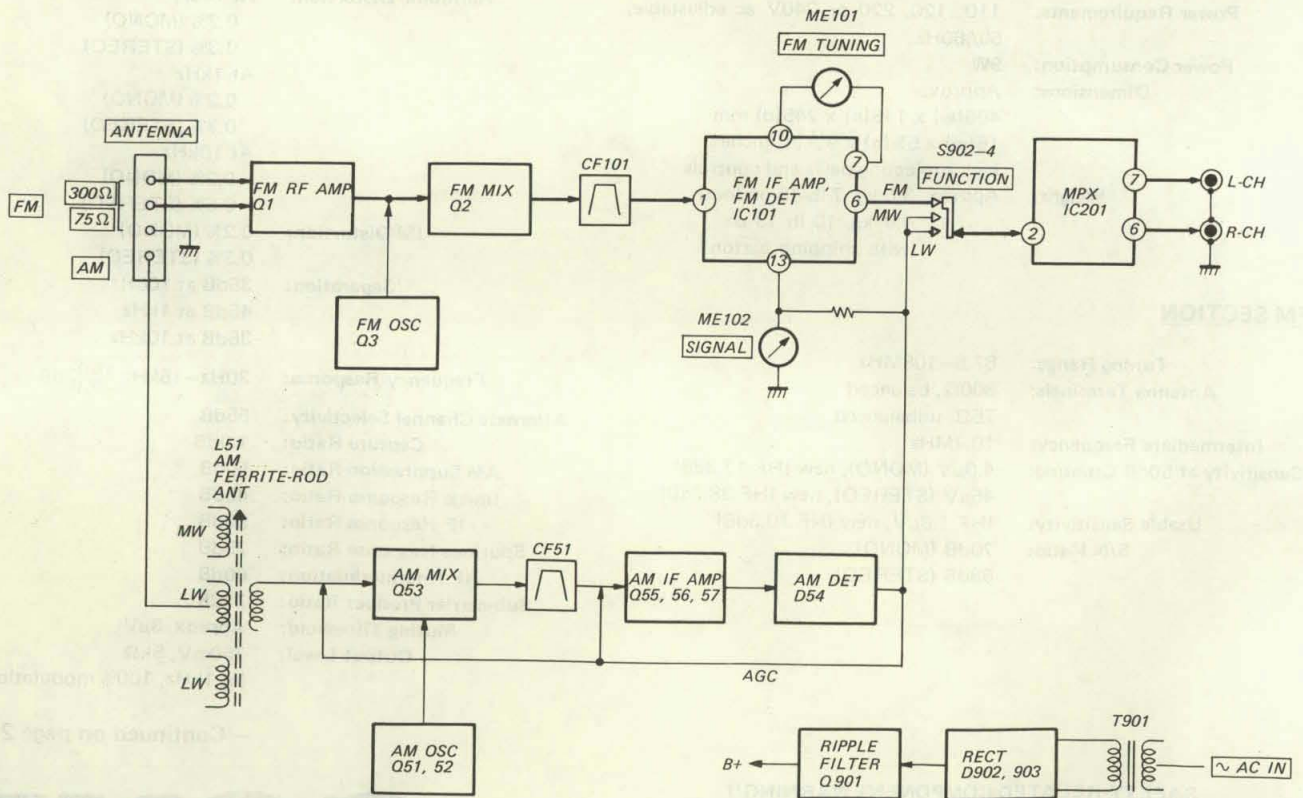

SECTION 2 REMOVAL

2-1. MAIN UNIT REMOVAL

Remove the case first and remove the parts in the numerical order as shown below.

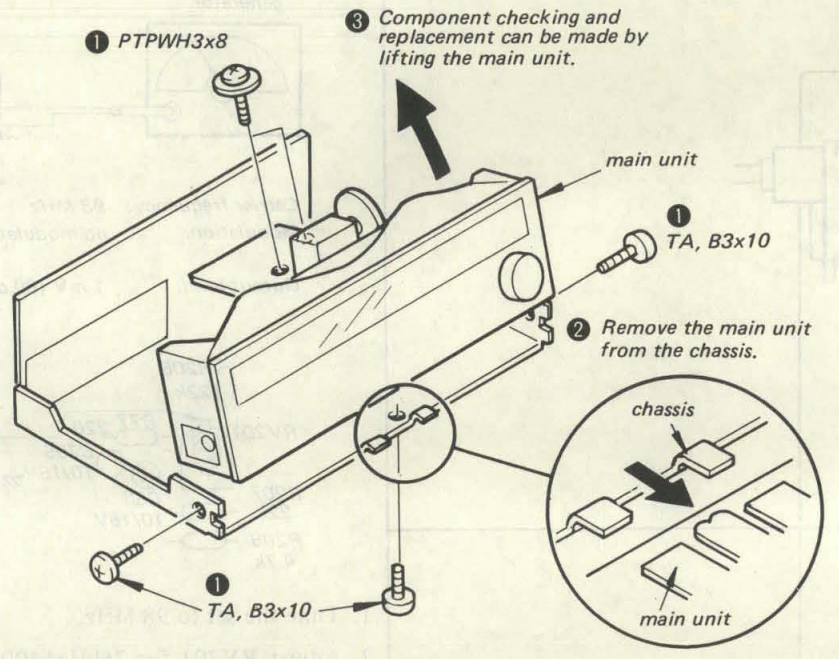

2-2. DIAL CORD STRINGING

1. Dial Cord Preparation

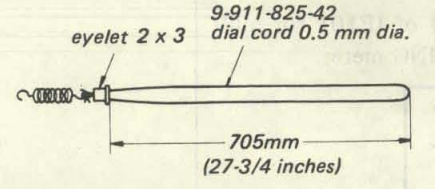

2. Dial Cord Stringing

1 Set the shaft of the tuning capacitor to full-clockwise position.

5 Do not slacken the dial cord.

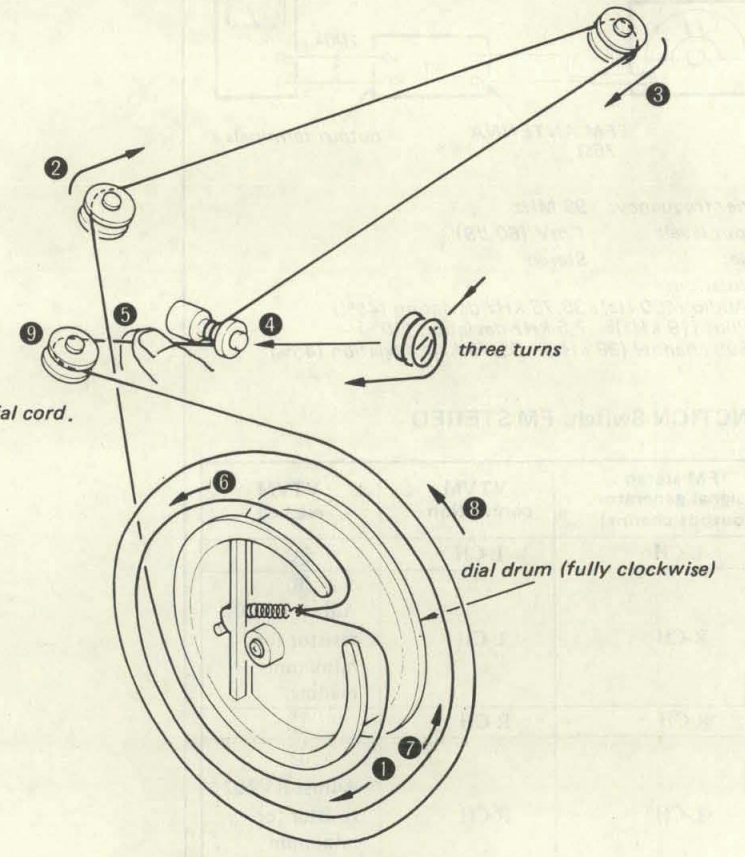

3. Dial Pointer Setting

Receive a broadcasting station and set the dial pointer on the dial scale.

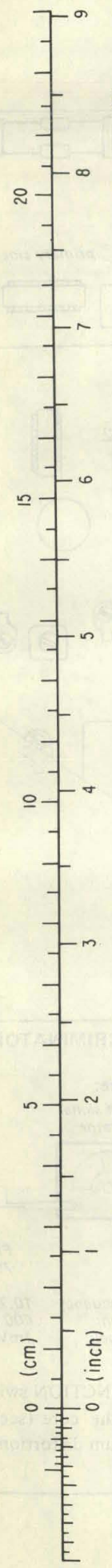

Digitized by www.freeservicemanuals.info 2017

SECTION 3
DISASSEMBLY

FM DISCRIMINATOR ALIGNMENT 1

Procedure:

1. Connect a 300Ω resistor across ANTENNA FM 300Ω terminals.
2. Detune the set.
3. Turn the core (primary side) of IF101 for null-point reading on the FM TUNING meter.



FM STEREO SEPARATION ADJUSTMENT

Procedure:

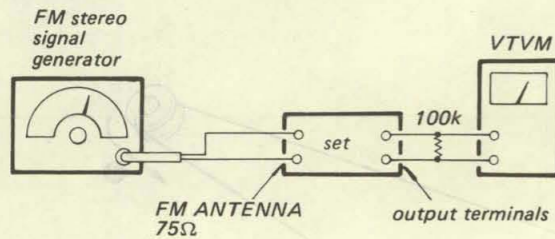

- Carrier frequency: 98 MHz
 Output level: 1 mV (60 dB)
 Mode: Stereo
 Modulation:
 Audio (400 Hz): 33.75 kHz deviation (45%)
 Pilot (19 kHz): 7.5 kHz deviation (10%)
 Sub channel (38 kHz): 33.75 kHz deviation (45%)

FUNCTION Switch: FM STEREO

FM stereo signal generator output channel	VTCM connection	VTCM reading
L-CH	L-CH	Ⓐ
R-CH	L-CH	Ⓑ [ⓑ] Adjust RV202 resistor for minimum reading.
R-CH	R-CH	Ⓒ
L-CH	R-CH	Ⓓ [ⓓ] Adjust RV202 resistor for minimum reading.

Stereo separation: Ⓐ - Ⓑ, Ⓒ - Ⓓ

The difference between separations Ⓐ → Ⓑ and Ⓒ → Ⓓ are to be equal.

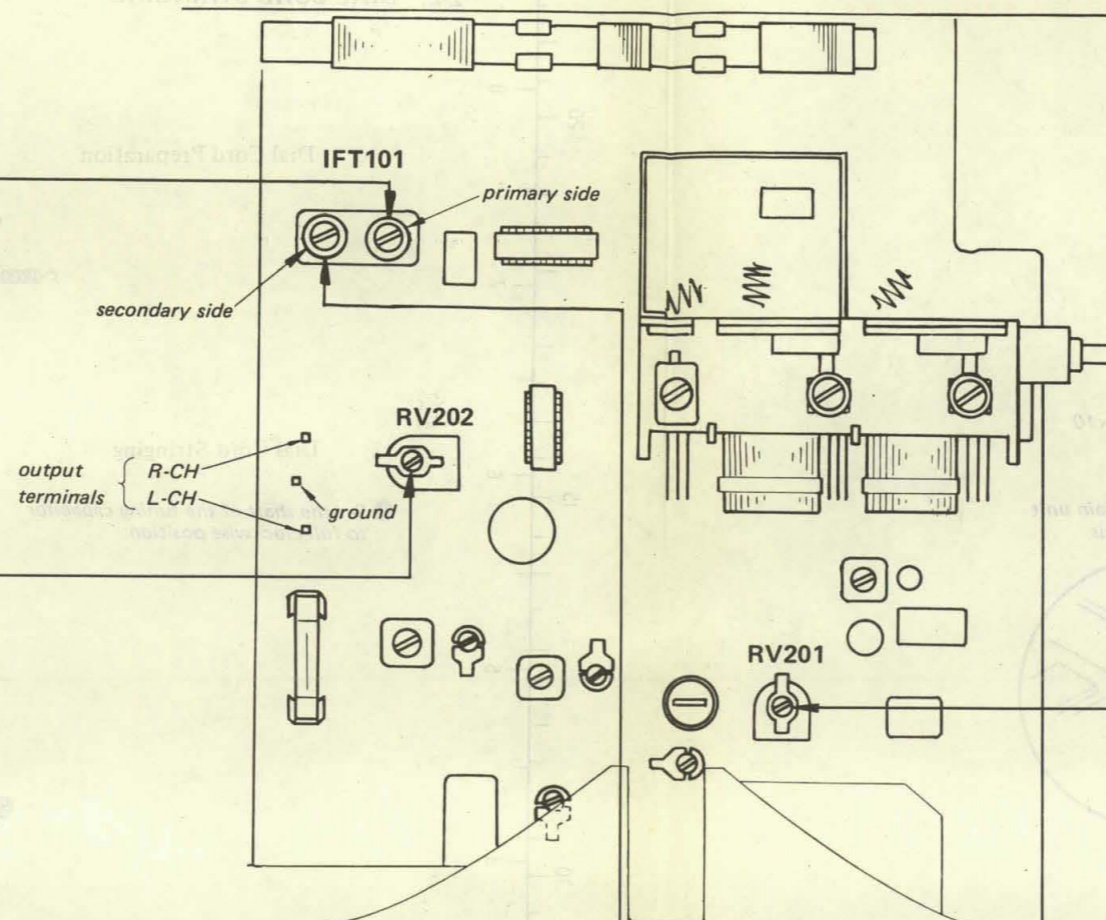

FM DISCRIMINATOR ALIGNMENT 2

Procedure:

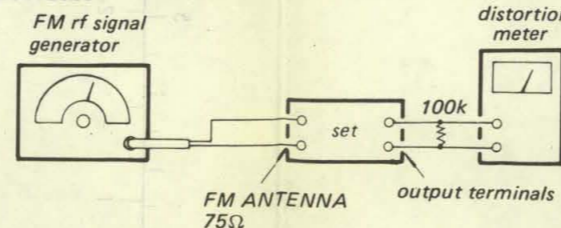

- Carrier frequency: 10.7 MHz
 Modulation: 400 Hz, 100%
 Output level: 1mV (60dB)

1. Set FUNCTION switch to FM MONO.
2. Turn the core (secondary side) of IFT101 for a minimum distortion reading on the distortion meter.

MPX ADJUSTMENT

A) Regular Method

Procedure:

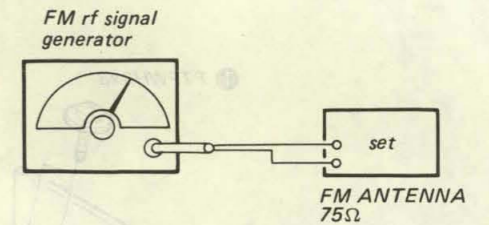

- Carrier frequency: 98 MHz
 Modulation: no modulation
 Output level: 1 mV (60 dB)

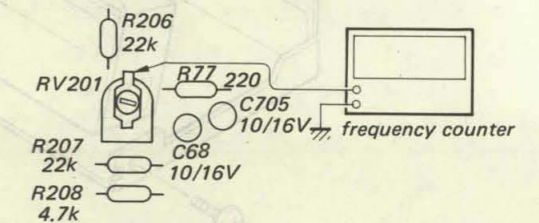

1. Tune the set to 98 MHz.
2. Adjust RV201 for 76kHz±400Hz on the counter.

B) Simple Method

Procedure:

1. Tune the set to the FM stereo broadcasting signal.
2. Turn RV201 clockwise or counterclockwise and memorize the lighting-up range of STEREO lamp.
3. Secure RV201 at the center in lighting-up range of both turns as shown below.

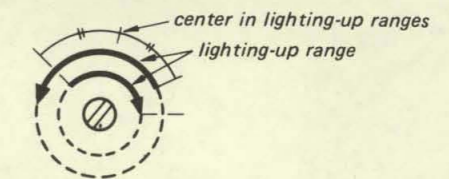

FM SECTION

FUNCTION Switch: FW

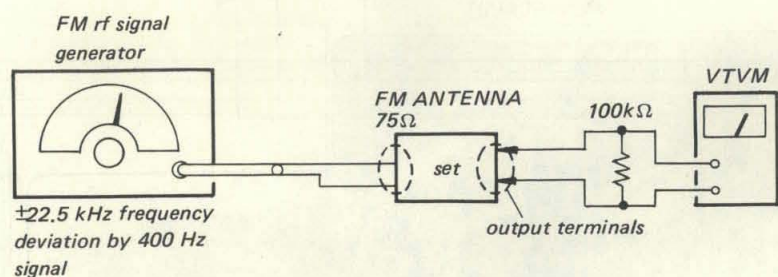

- Repeat the procedures in each adjustment several times, and the frequency coverage and tracking adjustments should be finally done by the trimmer capacitors.

FM FREQUENCY COVERAGE ADJUSTMENT	
Adjust for maximum reading on VTVM.	
87.1 Mhz (87.5 MHz)	L5
108.5 MHz (108 MHz)	CT3

() : in West Germany

FM TRACKING ADJUSTMENT	
Adjust for maximum reading on VTVM.	
L3, L4	87.1 MHz
L1, L2	(87.5 MHz)
CT2	108.4 MHz
CT1	(108 MHz)

() : in West Germany

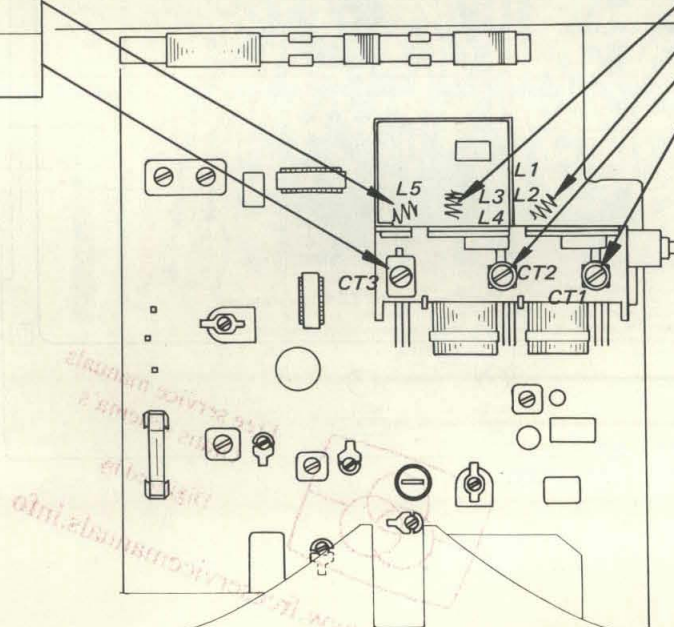

MW, LW SECTION

FUNCTION Switch: MW or LW

MW, LW FREQUENCY COVERAGE AND TRACKING 1 ADJUSTMENTS.

LW antenna selector: BUILT-IN ANT

AF rf signal generator

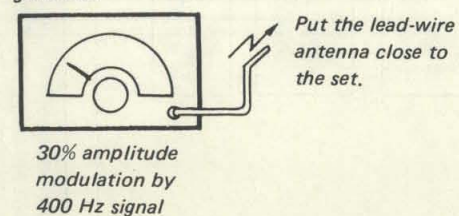

LW TRACKING 2 ADJUSTMENT.

LW antenna selector: EXT ANT

AM rf signal generator

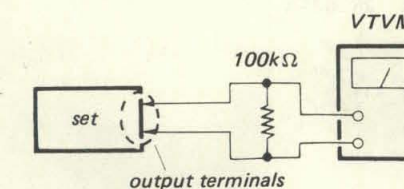
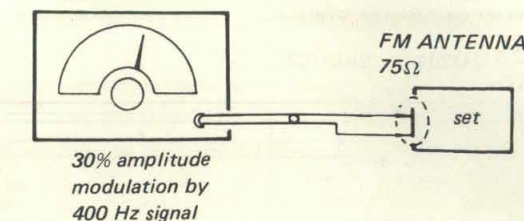

- Repeat the procedures in each adjustment several times, and the frequency coverage and tracking adjustments should be finally done by the trimmer capacitors.

MW TRACKING ADJUSTMENT	
Adjust for maximum reading on VTVM	
620 kHz	L51
1400 kHz	CT54

LW TRACKING 1 ADJUSTMENT	
1) LW antenna selector: BUILT-IN ANT position.	
2) Adjust for maximum reading on VTVM.	
L51	170 kHz
CT53	310 kHz

MW FREQUENCY COVERAGE ADJUSTMENT	
Adjust for maximum reading on VTVM	
1680 kHz	CT52
520 kHz	L52

AM IF ADJUSTMENT	
Adjust for maximum reading on VTVM.	
IFT51	455 kHz

L53	CT51
145 kHz	365 kHz
Adjust for maximum reading on VTVM.	
LW FREQUENCY COVERAGE ADJUSTMENT	

LW TRACKING 2 ADJUSTMENT	
1) LW antenna selector: EXT. ANT position	
2) Adjust for maximum reading on VTVM.	
L55	170 kHz

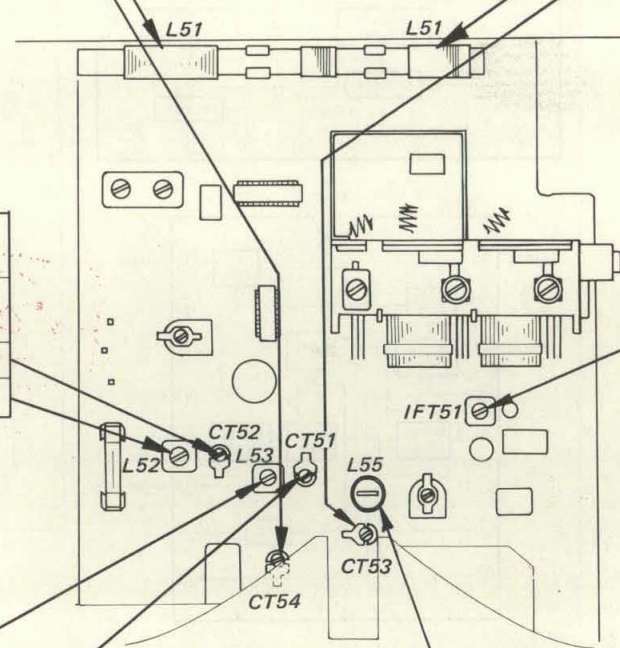

SECTION 4
DIAGRAMS

4-1. MOUNTING DIAGRAM
— Conductor Side —

Replacement Semiconductors
For replacement, use semiconductors except in ().

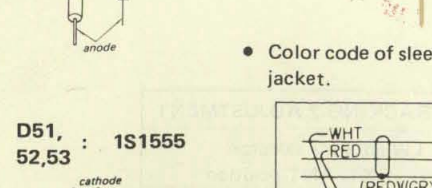
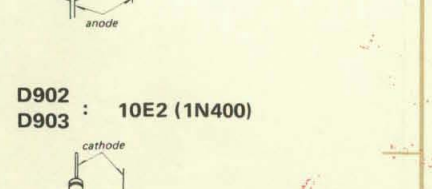
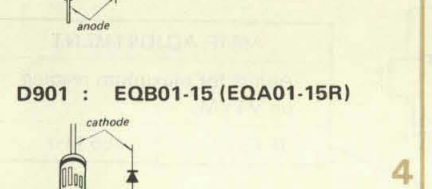
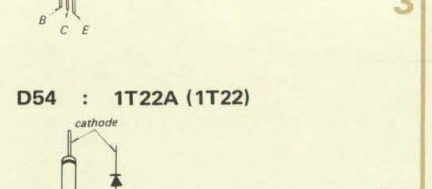
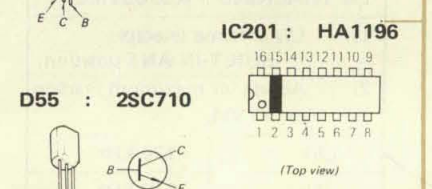
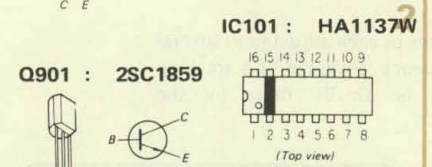
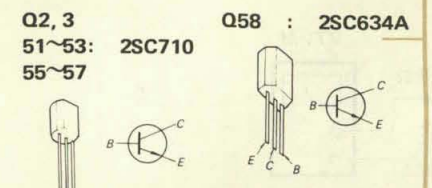
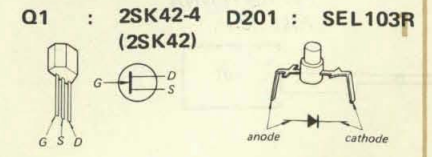

• Color code of sleeving over the end of the jacket.

— indicates side identified with part number.

— : B+ pattern
— : signal path
— : L-CH
— : R-CH

• Voltages are dc with respect to ground unless otherwise noted.
• Readings are taken under FM detuned conditions with a VOM (20 kΩ/V).
() : AM detuned.
[] : D201 turns OFF.
< > : FM tuned.
(()) : D201 turns ON.

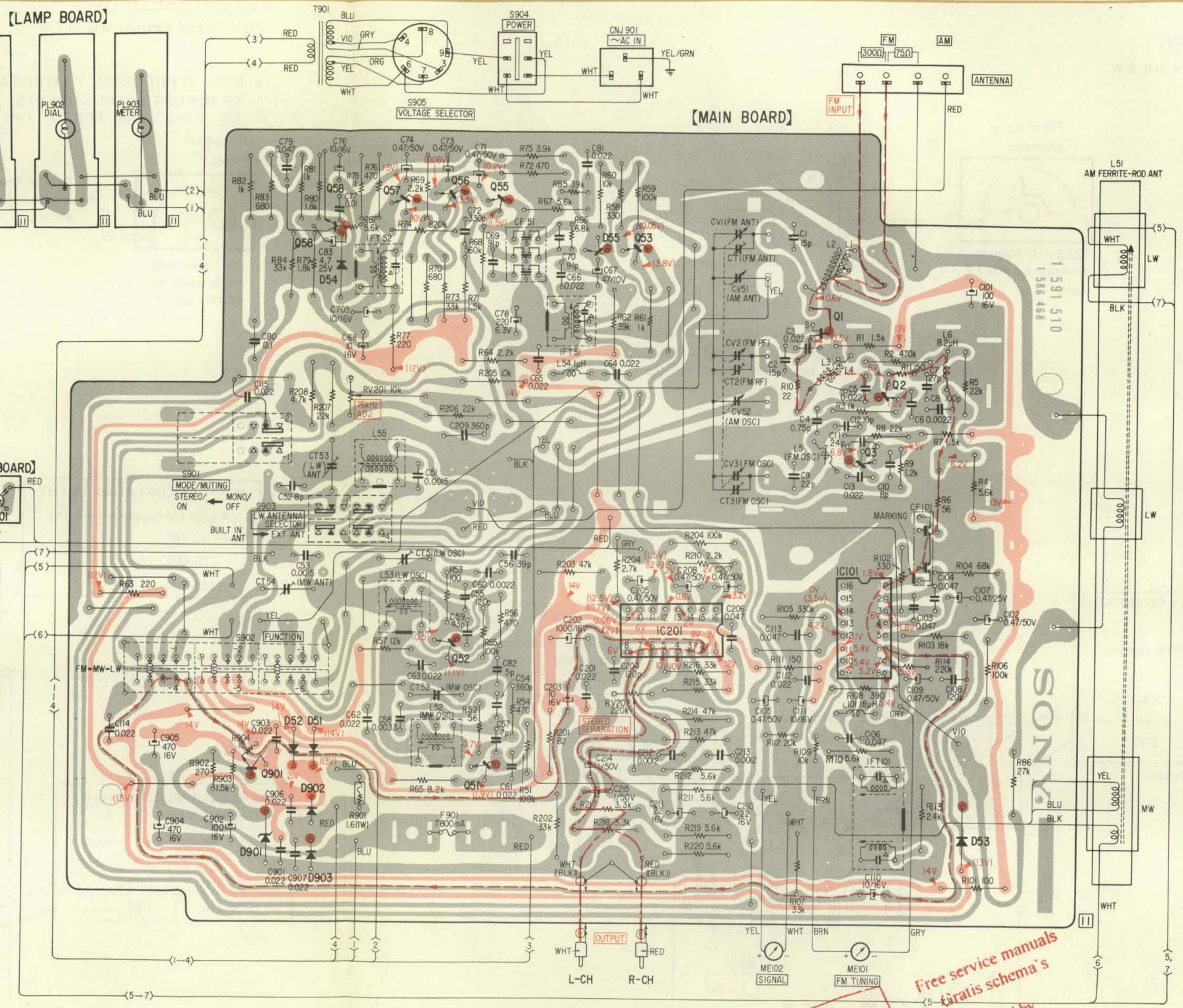
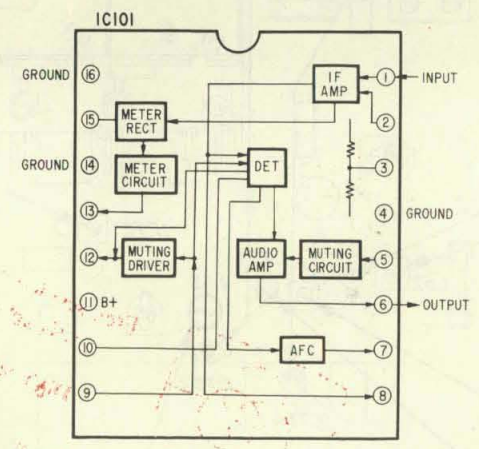
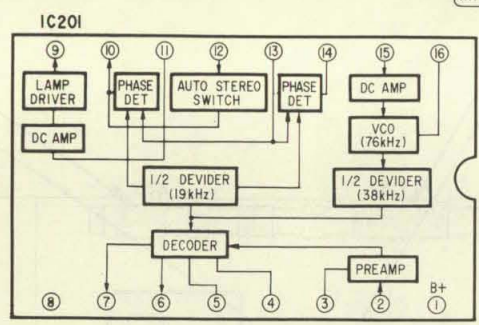
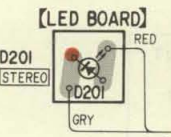
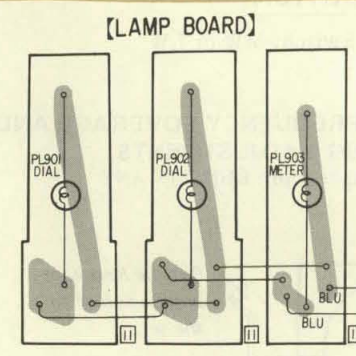

Q, IC	D
57 56 55	
58 53	54 55
	1
	2
	3
	201
	52 IC201 IC101
901 51	52 51
	902
	901 903
	53

Free service manuals
gratis schema's
Digitized by
www.freesevicemanuals.info

4-2. SCHEMATIC DIAGRAM

ST-11L ST-11L

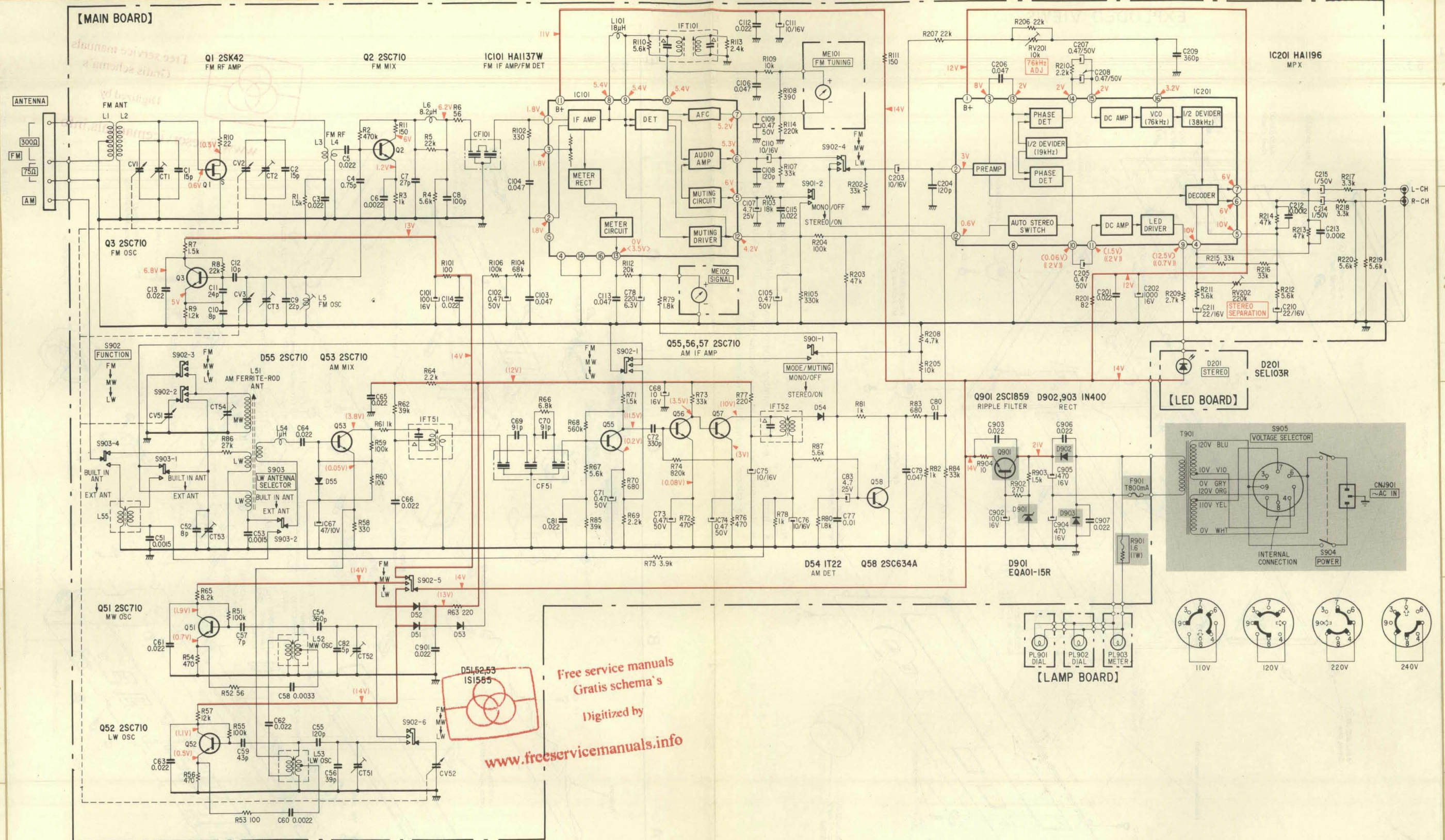

- Note:**
- All capacitors are in μF unless otherwise noted. $\text{pF} = \mu\text{F} \cdot 50$ WV or less are not indicated except for electrolytics.
 - All resistors are in ohms, $\frac{1}{4}\text{W}$ unless otherwise noted. $\text{k}\Omega = 1000\Omega$, $\text{M}\Omega = 1000\text{k}\Omega$
 - : fusible resistor.
 - \triangle : internal component.
 - Transistor is used for D55.
 - : B+ bus.
 - : Panel designation.
 - : direct connection to points marked on the chassis.
 - Voltage variations may be noted due to normal production tolerances.

- : adjustment for repair.
- Voltages are dc with respect to ground unless otherwise noted.
- Readings are taken under FM detuned conditions with a VOM (20 k Ω /V).
- () : AM detuned.
- [] : D201 turns OFF.
- < > : FM tuned.
- (()) : D201 turns ON.

• Switch

Ref. No.	Switch	Position
S901-1, 2	MODE/MUTING	MONO/OFF
S902-1 to 902-6	FUNCTION	FM
S903-1,2,4	LW ANTENNA SELECTOR	BUILT IN ANT
S904	POWER	OFF
S905	VOLTAGE SELECTOR	—

Note: The components identified by shading are critical for safety. Replace only with part number specified.

Digitized by www.freeservicemanuals.info 2017

SECTION 5
EXPLODED VIEWS

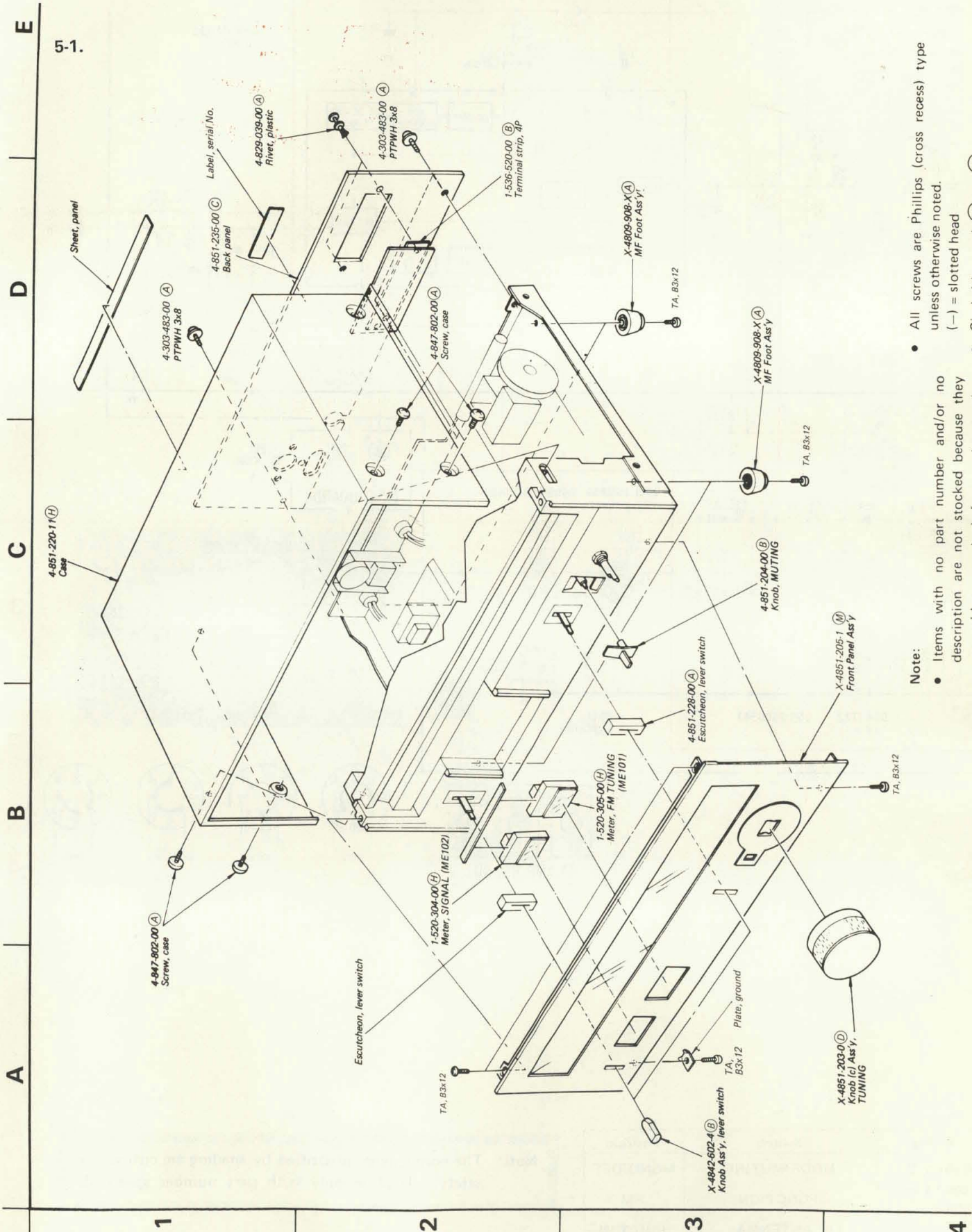

Note:

- Items with no part number and/or no description are not stocked because they are seldom required for routine service.
- All screws are Phillips (cross recess) type unless otherwise noted. (-) = slotted head
- Circled letters (A) to (Z) are applicable to European models only.

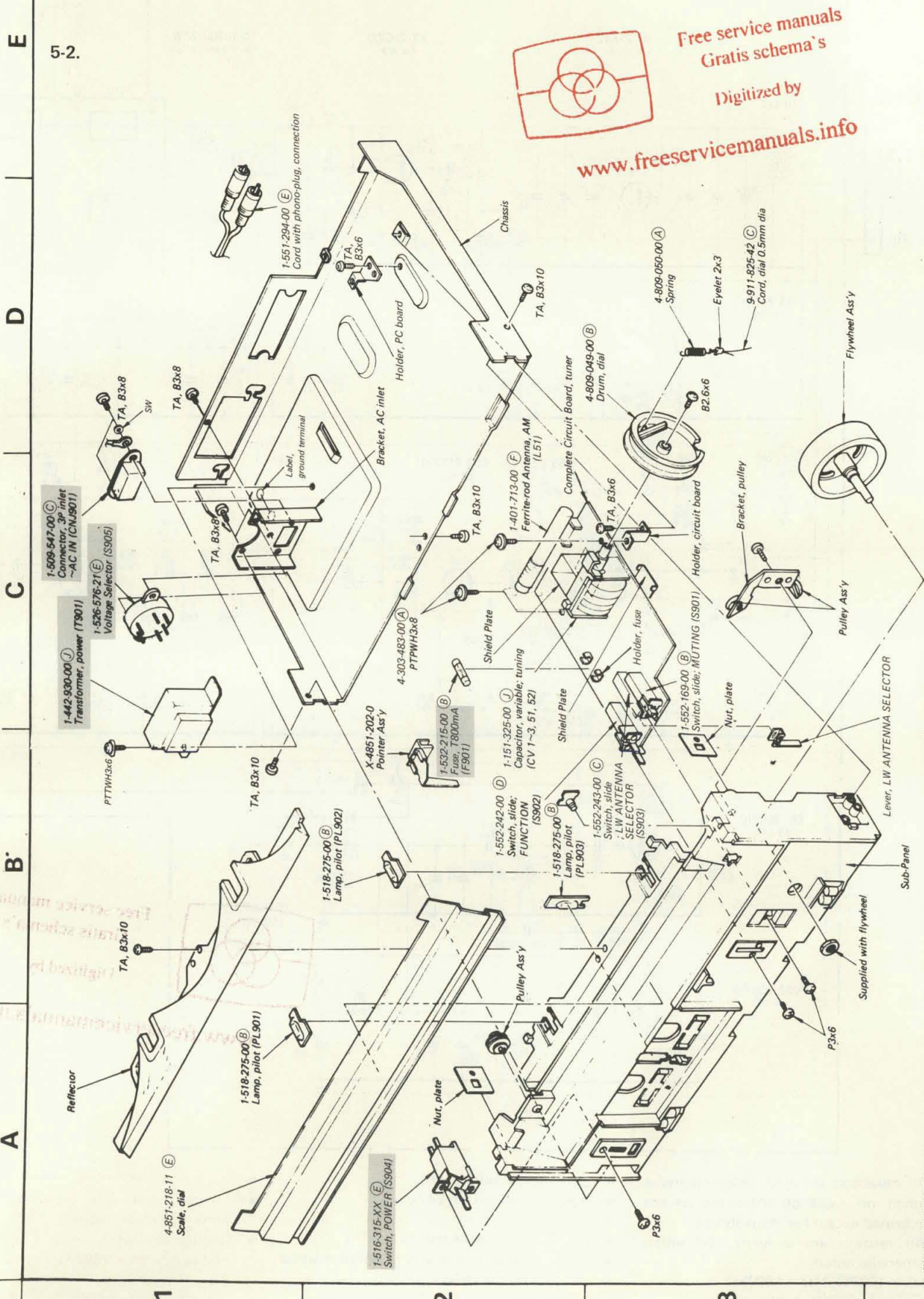

Note: The components identified by shading are critical for safety. Replace only with part number specified.

Note:

- Items with no part number and/or no description are not stocked because they are seldom required for routine service.
- All screws are Phillips (cross recess) type unless otherwise noted. (-) = slotted head
- Circled letters (A) to (Z) are applicable to European models only.

Free service manuals
Gratis schema's
Digitized by
www.freesevicemanuals.info

Digitized by www.freesevicemanuals.info 2017

SECTION 6 ELECTRICAL PARTS LIST

Note: Circled letters (A) to (Z) are applicable to European models only.

Ref. No.	Part No.	Description
SEMICONDUCTORS		
Transistors		
⇒ Q1	(C) 2SK42-4	
Q2, 3	(B) 2SC710	
Q51-53	(B) 2SC710	
Q55-57	(B) 2SC710	
Q58	(B) 2SC634A	
Q901	(B) 2SC1859	
ICs		
IC101	(H) HA1137W	
IC201	(G) HA1196	
Diodes		
D51-53	(B) 1S1555	
⇒ D54	(B) 1T22A	
D55	(B) 2SC710	
D201	(B) SEL103R	
⇒ D901	(B) EQB01-15	
⇒ D902, 903	(B) 10E2	
COILS		
L1	1-420-875-00 (A) Coreless	
L4	1-405-612-00 (A) FM RF	
L6	1-407-692-00 (A) 8.20μH, microinductor	
L51	1-401-713-00 (F) Ferrite-rod Antenna	
L52	1-405-732-00 (B) MW OSC	
L53	1-405-731-00 (B) LW OSC	
L54	1-407-178-XX (A) 1μH, microinductor	
L55	1-401-676-00 (B) LW EXT ANTENNA	
L101	1-407-741-00 (B) 18μH, microinductor	
IFT051	1-404-089-00 (C) IFT	
IFT052	1-404-064-00 (B) AM Detector	
IFT101	1-404-011-00 (C) FM Discriminator	

⇒: Due to standardization, interchangeable replacemer may be substituted for parts specified in the diagrams.

Ref. No.	Part No.	Description
TRANSFORMER		
T901	1-442-930-00	Power
CAPACITORS		
All capacitors are in μF and ceramic unless otherwise noted. 50WV or less are not indicated except for electrolytics. pF = μμF, elect = electrolytic		
C1, 2	1-102-951-11 (A) 15p	
C3	1-101-924-11 (A) 0.022	
C4	1-101-586-11 (A) 0.75p	
C5	1-101-924-11 (A) 0.022	
C6	1-102-121-11 (A) 0.0022	
C7	1-102-961-11 (A) 27p	
C8	1-102-973-11 (A) 100p	
C9	1-102-600-11 (A) 22p	
C10	1-102-684-11 (A) 8p	
C11	1-102-601-11 (A) 24p	
C12	1-102-858-11 (A) 10p	
C13	1-101-924-11 (A) 0.022	
C51	1-103-729-11 (A) 0.0015	polystyrol
C52	1-102-945-11 (A) 8p	
C53	1-103-729-11 (A) 0.0015	polystyrol
C54	1-103-714-11 (A) 360p	polystyrol
C55	1-103-703-11 (A) 120p	polystyrol
C56	1-102-965-11 (A) 39p	
C57	1-102-944-11 (A) 7p	
C58	1-102-123-11 (A) 0.0033	
C59	1-102-966-11 (A) 43p	
C60	1-102-121-11 (A) 0.0022	
C61 ~ C66	1-101-924-11 (A) 0.022	
C67	1-121-352-11 (A) 47	10V elect
C68	1-121-651-11 (A) 10	16V elect
C69, 70	1-102-972-11 (A) 91p	
C71	1-121-726-11 (A) 0.47	50V elect
C72	1-102-820-11 (A) 330p	
C73, 74	1-121-726-11 (A) 0.47	50V elect
C75, 76	1-121-651-11 (A) 10	16V elect
C77	1-161-013-11 (A) 0.01	(boundary layer)

Note: The components identified by shading are critical for safety. Replace only with part number specified.

Ref. No.	Part No.	Description
C78	1-121-419-11 (B) 220	6.3V elect
C79	1-161-021-11 (A) 0.047	(boundary layer)
C80	1-101-797-11 (A) 0.1	
C81	1-101-924-11 (A) 0.022	
C82	1-102-281-11 (A) 5p	
C83	1-121-395-11 (A) 4.7	25V elect
C101	1-121-415-11 (B) 100	16V elect
C102	1-121-726-11 (A) 0.47	50V elect
C103, 104	1-101-925-11 (A) 0.047	
C105	1-121-726-11 (A) 0.47	50V elect
C106	1-101-925-11 (A) 0.047	
C107	1-121-395-11 (A) 4.7	25V elect
C108	1-102-816-11 (A) 120p	
C109	1-121-726-11 (A) 0.47	50V elect
C110, 111	1-121-651-11 (A) 10	16V elect
C112	1-101-924-11 (A) 0.022	
C113	1-101-925-11 (A) 0.047	
C114, 115	1-101-924-11 (A) 0.022	
C201	1-101-924-11 (A) 0.022	
C202	1-121-245-11 (B) 1000	16V elect
C203	1-121-651-11 (A) 10	16V elect
C204	1-102-816-11 (A) 120p	
C205	1-121-726-11 (A) 0.47	50V elect
C206	1-161-021-11 (A) 0.047	(boundary layer)
C207, 208	1-121-726-11 (A) 0.47	50V elect
C209	1-103-714-11 (A) 360p	polystyrol
C210, 211	1-121-479-11 (A) 22	16V elect
C212, 213	1-161-002-11 (A) 0.0012	(boundary layer)
C214, 215	1-121-391-11 (A) 1	50V elect
C901	1-101-924-11 (A) 0.022	
C902	1-121-415-11 (B) 100	16V elect
C903	1-101-924-11 (A) 0.022	
C904, 905	1-121-426-11 (B) 470	16V elect
C906, 907	1-101-924-11 (A) 0.022	
CT51-54	1-141-138-XX (B)	Trimmer
CV1-3	1-151-325-00 (J)	Tuning

Note: Circled letters ((A) to (Z)) are applicable to European models only.

Ref. No.	Part No.	Description
CV51, 52	1-151-325-00 (J)	Tuning

RESISTORS

All resistors are in ohms. Common 1/4W carbon resistors are omitted. Check schematic diagram for values.

R901 1-213-041-11 (A) 1.6 1W fusible

RV201 1-222-645-XX (B) 10K, adjustable

RV202 1-222-649-XX (B) 220K, adjustable

SWITCHES

S901 1-552-169-00 (B) Slide, MODE/MUTING

S902 1-552-242-00 (D) Slide, FUNCTION

S903 1-552-243-00 (C) Slide, LW ANTENNA SELECTOR

S904 1-516-315-XX (E) Lever, POWER

S905 1-526-576-21 (E) Voltage Selector

JACKS

CNJ001 1-536-520-00 (B) Terminal, 4P

CNJ901 1-509-547-00 (C) Connector, 3P inlet; AC IN

FUSE

F901 1-532-215-00 (B) T800mA

MISCELLANEOUS

CF51 1-527-305-00 (D) Filter

CF101 1-231-304-00 (D) Filter, 10.7MHz

ME101 1-520-305-00 (H) Meter, FM TUNING

ME102 1-520-304-00 (H) Meter, SIGNAL

PL901 ~ 903 1-518-275-00 (B) Pilot Lamp

1-501-161-00 (F) Feeder Antenna

1-551-294-00 (E) Cord with phono-plug, connection

Note: The components identified by shading are critical for safety. Replace only with part number specified.

Note: Circled letters (A to Z) are applicable to European models only.

<u>Ref. No.</u>	<u>Part No.</u>	<u>Description</u>
ACCESSORIES & PACKING MATERIALS		
	3-701-630-00	(A) Bag, plastic
	3-770-341-11	(E) Manual, instruction
	4-851-242-00	(E) Carton
	4-851-243-00	(B) Cushion
	4-891-037-00	(A) Bag, plastic

Ref. No.	Description	Part No.	Quantity
	Accessories & Packing Materials		
	3-701-630-00	(A)	1
	3-770-341-11	(E)	1
	4-851-242-00	(E)	1
	4-851-243-00	(B)	1
	4-891-037-00	(A)	1

www.freesevicemanuals.info
 Digitized by
 freesevicemanuals.info



Sony Corporation
 1-10-1

HARDWARE NOMENCLATURE

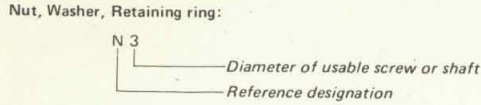
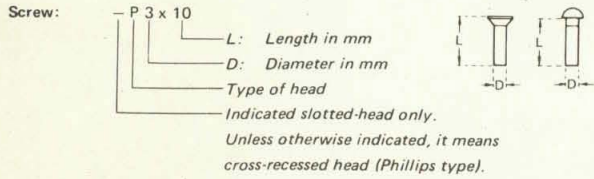

Reference Designation	Shape	Description	Remarks
SCREWS			
P		pan-head screw	binding-head (B) screw for replacement
PWH		pan-head screw with washer face	binding-head (B) screw and flat washer for replacement
PS PSP		pan-head screw with spring washer	binding-head (B) screw and spring washer for replacement
PSW PSPW		pan-head screw with spring and flat washers	binding-head (B) screw and spring and flat washers for replacement
R		round-head screw	binding-head (B) screw for replacement
K		flat-countersunk-head screw	
RK		oval-countersunk-head screw	
B		binding-head screw	
T		truss-head screw	binding-head (B) screw for replacement
F		flat-fillister-head screw	
RF		fillister-head screw	
BV		braizer-head screw	

Reference Designation	Shape	Description	Remarks
SELF-TAPPING SCREWS			
TA		self-tapping screw	ex: TA, P 3 x 10
PTP		pan-head self-tapping screw	binding-head self-tapping (TA, B) screw for replacement
PTPWH		pan-head self-tapping screw with washer face	binding-head self-tapping (TA, B) screw and flat washer for replacement
PTTWH		pan-head thread-rolling screw with washer face	binding-head (B) screw and flat washer for replacement
SET SCREWS			
SC		set screw	
SC		hexagon-socket set screw	ex: SC 2.6 x 4, hexagon socket
NUT			
N		nut	
WASHERS			
W		flat washer	
SW		spring washer	
LW		internal-tooth lock washer	ex: LW3, internal
LW		external-tooth lock washer	ex: LW3, external
RETAINING RINGS			
E		retaining ring	
G		grip-type retaining ring	

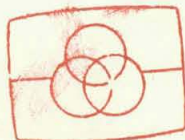

Free service manuals
Gratis schema's

Digitized by

www.freeservicemanuals.info