

SERVICE MANUAL

BE-3D CHASSIS

MODEL	COMMANDER	DEST.	CHASSIS NO.	MODEL	COMMANDER	DEST.	CHASSIS NO.
<i>KV-29C1A</i>	<i>RM-839</i>	<i>Italian</i>	<i>SCC-K05D-A</i>	<i>KV-29C1E</i>	<i>RM-839</i>	<i>Spanish</i>	<i>SCC-K06D-A</i>
<i>KV-29C1B</i>	<i>RM-839</i>	<i>French</i>	<i>SCC-K01D-A</i>	<i>KV-29C1K</i>	<i>RM-839</i>	<i>OIRT</i>	<i>SCC-K08F-A</i>
<i>KV-29C1D</i>	<i>RM-839</i>	<i>AEP</i>	<i>SCC-K07D-A</i>	<i>KV-29C1R</i>	<i>RM-839</i>	<i>OIRT</i>	<i>SCC-K08G-A</i>
<i>KV-29C1D 1</i>	<i>RM-839</i>	<i>AEP</i>	<i>SCC-K07J-A</i>				

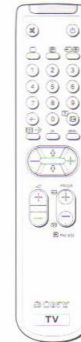

TRINITRON® COLOR TV
SONY®



ITEM	MODEL	Television System	Channel Coverage	Colour System
Italian		B/G/H	VHF: E2-E12, S1-S20, A-H, H1,H2 UHF: E21-E69	PAL NTSC3.58/4.43 (video input only)
French		B/G/H, D/K, L, I	L SECAM VHF: F2-F10 UHF: F21-F69 TV CABLE TV (1) VHF: B-Q UHF: S21-S44 PAL B/G/H VHF: E2-E12 UHF: E21-E69 CABLE TV (1) : S1-S41 CABLE TV (2) : S01-S05, M1-M10, U1-U10 ITALIA VHF: A-H, H1, H2 PAL I UHF: B21-B69 D/K VHF: R01-R20 UHF: B21-B69 CABLE TV (1) : S1-S41 CABLE TV (2) : S01-S05, S42-S46	PAL, SECAM NTSC3.58/4.43 (video input only)
AEP		B/G/H, D/K	B/G/H VHF: E2-E12 UHF: S1-S20 CABLE TV (1) : S1-S41 CABLE TV (2) : S01-S05, M1-M10, U1-U10 ITALIA VHF: A-H, H1, H2 D/K VHF: R01-R20 UHF: B21-B69 CABLE TV (1) : S1-S41 CABLE TV (2) : S01-S05, S42-S46	PAL, SECAM NTSC3.58/4.43 (video input only)
Spanish		B/G/H, D/K	PAL B/G/H VHF: E2-E12 UHF: E21-E69 CABLE TV (1) : S1-S41 CABLE TV (2) : S01-S05, M1-M10, U1-U10 ITALIA VHF: A-H, H1, H2 D/K VHF: R01-R20 UHF: B21-B69 CABLE TV (1) : S1-S41 CABLE TV (2) : S01-S05, S42-S46	PAL, SECAM NTSC3.58/4.43 (video input only)
OIRT		B/G/H, D/K	B/G/H VHF: E2-E12 UHF: E21-E69 CABLE TV (1) : S1-S41 CABLE TV (2) : S01-S05, M1-M10, U1-U10 ITALIA VHF: A-H, H1, H2 D/K VHF: R01-R12 UHF: R21-R69 CABLE TV (1) : S1-S41 CABLE TV (2) : S01-S05, S42-S46	PAL, SECAM NTSC3.58/4.43 (video input only)

MODEL	29C1A	29C1B	29C1D 29C1D 1	29C1E	29C1K 29C1R
Power Consumption	85W	95W	95W	95W	95W

SPECIFICATIONS

Picture Tube Super Trinitron
Approx. 72 cm (29 inches)
(Approx. 68 cm picture measured diagonally)
110° -deflection

Rear/Front Terminals

[REAR]

- ➔ 1 21-pin Euro connector (CENELEC standard)
 - Inputs for audio / video signals
 - Inputs for RGB
 - Outputs for TV audio and video signals
- ➔ 2/➔ 2, 21-pin Euro connector (CENELEC standard)
 - Inputs for audio / video signals
 - Inputs for S video
 - Outputs for TV audio and video signals (selectable)

[FRONT]

- ➔ 3, Video input - phono jack
- ➔ 3, Audio inputs - phono jacks
- ➔ 3, S video input - 4 pin DIN
(KV-29C1D 1 does not have ➔ 3, ➔ 3 or ➔ 3)
- 🎧 Stereo minijack - headphone jack

Sound output

Left/Right 2x5W (RMS)
2x10W (music power)

Dimensions 794x567x533 mm approx.

Weight Approx. 43.0 kg

Supplied accessories RM-839 Remote Commander (1)
Batteries R6 (2)

Other features Fastext, TOPTXT

[RM-839]

Remote control system	Infrared control
Power requirements	3V dc (2 batteries) R6 (size AA)
Dimensions	Approx. 210x45x24 mm (w/h/d)
Weight	Approx. 91g (Not including battery)

Design and specifications are subject to change without notice.

Model name Item	KV-29C1A	KV-29C1B	KV-29C1D	KV-29C1D 1	KV-29C1E	KV-29C1K KV-29C1R
PIP	OFF	OFF	OFF	OFF	OFF	OFF
MPIP	OFF	OFF	OFF	OFF	OFF	OFF
Scart 1	ON	ON	ON	ON	ON	ON
Scart 2	ON	ON	ON	ON	ON	ON
Front in (3)	ON	ON	ON	OFF	ON	ON
Scart 4	OFF	OFF	OFF	OFF	OFF	OFF
AKB in 16:9 mode	ON	ON	ON	ON	ON	ON
TXT	ON	ON	ON	ON	ON	ON
FLOF	ON	ON	ON	ON	ON	ON
TOP	ON	ON	ON	ON	ON	ON
Norm B/G/H	ON	ON	ON	ON	ON	ON
Norm I	OFF	ON	OFF	OFF	OFF	OFF
Norm D/K	OFF	ON	ON	ON	ON	ON
Norm AUS	OFF	OFF	OFF	OFF	OFF	OFF
Norm L	OFF	ON	OFF	OFF	OFF	OFF
Norm SAT	OFF	OFF	OFF	OFF	OFF	OFF
Norm M	OFF	OFF	OFF	OFF	OFF	OFF
Language Preset	Italian	French	German	German	Spanish	OIRT

21 pin connector ( 1,  2 /  2)

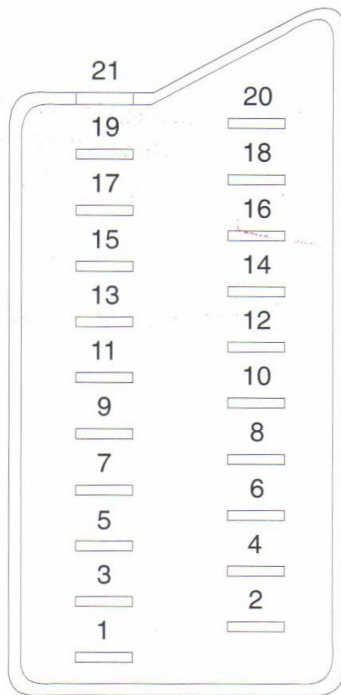
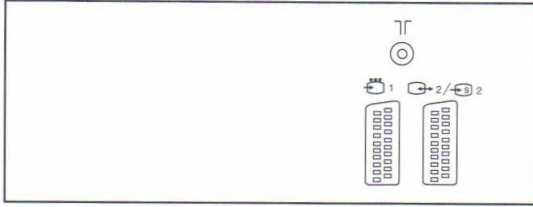

Pin No.	1	2	4	Signal	Signal Level
1	<input type="radio"/>	<input type="radio"/>	<input type="radio"/>	Audio output B (Right)	Standard level : 0.5V rms Output impedance : Less than 1k ohms*
2	<input type="radio"/>	<input type="radio"/>	<input type="radio"/>	Audio input B (Right)	Standard level : 0.5V rms Output impedance : More than 10k ohms*
3	<input type="radio"/>	<input type="radio"/>	<input type="radio"/>	Audio output A (Left)	Standard level : 0.5V rms Output impedance : Less than 1k ohm*
4	<input type="radio"/>	<input type="radio"/>	<input type="radio"/>	Ground (Audio)	
5	<input type="radio"/>	<input type="radio"/>	<input type="radio"/>	Ground (Blue)	
6	<input type="radio"/>	<input type="radio"/>	<input type="radio"/>	Audio input A (Left)	Standard level : 0.5V rms Output impedance : Less than 10k ohm*
7	<input type="radio"/>	<input checked="" type="radio"/>	<input checked="" type="radio"/>	Blue input	0.7 ± 3dB, 75 ohms, positive
8	<input type="radio"/>	<input type="radio"/>	<input type="radio"/>	Function select (AV control)	High state (9.5 - 12V) : Part mode Low state (0 - 2V) : TV mode Input impedance : More10k ohms Input capacitance : Less than 2nF
9	<input type="radio"/>	<input type="radio"/>	<input type="radio"/>	Ground (Green)	
10	<input type="radio"/>	<input type="radio"/>	<input type="radio"/>	Open	
11	<input type="radio"/>	<input checked="" type="radio"/>	<input checked="" type="radio"/>	Green	
12	<input type="radio"/>	<input type="radio"/>	<input type="radio"/>	Open	
13	<input type="radio"/>	<input type="radio"/>	<input type="radio"/>	Ground (Red)	
14	<input type="radio"/>	<input type="radio"/>	<input type="radio"/>	Ground (Blanking)	
15	<input type="radio"/>	<input type="radio"/>	<input type="radio"/>	Red input	0.7 ± 3dB, 75 ohms, positive
	<input type="radio"/>	<input type="radio"/>	<input type="radio"/>	(S signal) chroma input	0.7 ± 3dB, 75 ohms, positive
16	<input type="radio"/>	<input checked="" type="radio"/>	<input checked="" type="radio"/>	Blanking input (Ys signal)	High state (1 - 3V) Low state (0 - 0.4V) Input impedance : 75 ohms
17	<input type="radio"/>	<input type="radio"/>	<input type="radio"/>	Ground (Video output)	
18	<input type="radio"/>	<input type="radio"/>	<input type="radio"/>	Ground (Video input)	
19	<input type="radio"/>	<input type="radio"/>	<input type="radio"/>	Video output	1V ± 3dB, 75ohms, positive sync : 0.3V (-3 + 10dB)
20	<input type="radio"/>	<input type="radio"/>	<input type="radio"/>	Video input	1V ± 3dB, 75ohms, positive sync : 0.3V (-3 + 10dB)
	<input type="radio"/>	<input type="radio"/>	<input type="radio"/>	Video input Y (S signal)	1V ± 3dB, 75ohms, positive sync : 0.3V (-3 + 10dB)
21	<input type="radio"/>	<input type="radio"/>	<input type="radio"/>	Common ground (plug, shield)	

Connected Not Connected (Open) * at 20Hz - 20kHz

Pin No.	Signal	Signal Level
1	Ground	
2	Ground	
3	Y (S signal) input	1V ± 3dB 75 ohm, positive Sync. 0.3V -3 + 10dB
4	C (S signal) input	0.3V ± 3dB 75ohm, positive Sync.

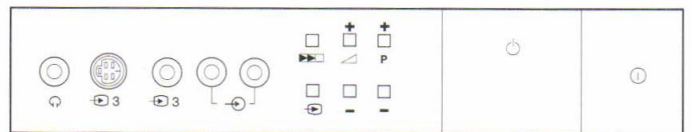
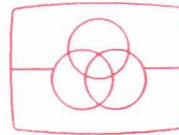

TABLE OF CONTENTS

<i>Section</i>	<i>Title</i>	<i>Page</i>	<i>Section</i>	<i>Title</i>	<i>Page</i>
1. GENERAL			5. DIAGRAMS		
	Overview	7	5-1.	Block Diagrams	33
	Getting Started	8	5-2.	Circuit Boards Location	38
	TV Operation	9	5-3.	Schematic Diagrams and Printed Wiring Boards	38
	Advanced Operations	10		*D Board	43
	Teletext	16		*A Board	48
	Optional Equipment	17		*C Board	58
	For Your Information	19		*D2 Board	60
				*VM Board	60
2. DISASSEMBLY				*IF Block [VIF (AEP)]	63
2-1.	Rear Cover Removal	20		*IF Block [VIF (FR)]	63
2-2.	Chassis Assy Removal	20		IC Blocks	65
2-3.	Service Position	20	5-4.	Semiconductors	67
2-4.	Wire Dressing	20			
2-5.	A Board Removal	21	6. EXPLODED VIEWS		
2-6.	Extension Board	21	6-1.	Chassis	69
2-7.	Picture Tube Removal	21	6-2.	Picture Tube	70
3. SET-UP ADJUSTMENTS			7. ELECTRICAL PARTS LIST		71
3-1.	Beam Landing	23			
3-2.	Convergence	24			
3-3.	White Balance	26			
4. CIRCUIT ADJUSTMENTS					
4-1.	Electrical Adjustments	27			
4-2.	Test Mode 2 :	30			
4-3.	BE-3D Self Diagnostic Software	31			



Free service manuals
Gratis schema's

Digitized by

www.freesevicemanuals.info

CAUTION

SHORT CIRCUIT THE ANODE OF THE PICTURE TUBE AND THE ANODE CAP TO THE METAL CHASSIS, CRT SHIELD, OR CARBON PAINTED ON THE CRT, AFTER REMOVING THE ANODE.

WARNING !!

AN ISOLATION TRANSFORMER SHOULD BE USED DURING ANY SERVICE TO AVOID POSSIBLE SHOCK HAZARD, BECAUSE OF LIVE CHASSIS.

THE CHASSIS OF THIS RECEIVER IS DIRECTLY CONNECTED TO THE AC POWER LINE.

SAFETY-RELATED COMPONENT WARNING!!

COMPONENTS IDENTIFIED BY SHADING AND MARK  ON THE SCHEMATIC DIAGRAMS, EXPLODED VIEWS AND, IN THE PARTS LIST ARE CRITICAL FOR SAFE OPERATION. REPLACE THESE COMPONENTS WITH SONY PARTS WHOSE PART NUMBERS APPEAR AS SHOWN IN THIS MANUAL OR IN SUPPLEMENTS PUBLISHED BY SONY.

ATTENTION

APRES AVOIR DECONNECTE LE CAP DE L'ANODE, COURT-CIRCUITER L'ANODE DU TUBE CATHODIQUE ET CELUI DE L'ANODE DU CAP AU CHASSIS METALLIQUE DE L'APPAREIL, OU AU COUCHE DE CARBONE PEINTE SUR LE TUBE CATHODIQUE OU AU BLINDAGE DU TUBE CATHODIQUE.

ATTENTION !!

AFIN D'EVITER TOUT RISQUE D'ELECTROCUTION PROVENANT D'UN CHÂSSIS SOUS TENSION, UN TRANSFORMATEUR D'ISOLEMENT DOIT ETRE UTILISÉ LORS DE TOUT DÉPANNAGE. LE CHÂSSIS DE CE RÉCEPTEUR EST DIRECTEMENT RACCORDÉ À L'ALIMENTATION SECTEUR.

ATTENTION AUX COMPOSANTS RELATIFS À LA SÉCURITÉ!!

LES COMPOSANTS IDENTIFIÉS PAR UNE TRAME ET PAR UNE MARQUE  SUR LES VUES EXPLOSÉES ET LES LISTES DE PIÈCES SONT D'UNE IMPORTANCE CRITIQUE PUR LA SÉCURITÉ DU FONCTIONNEMENT. NE LES REMPLACER QUE PAR DES COMPOSANTS SONY DONT LE NUMÉRO DE PIÈCE EST INDIQUÉ DANS LE PRÉSENT MANUEL OU DANS DES SUPPLÉMENTS PUBLIÉS PAR SONY.

SECTION 1 GENERAL

The operating instructions mentioned here are partial abstracts from the Operating Instruction Manual. The page numbers of the Operating Instruction Manual remain as in the manual.

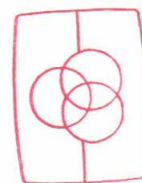
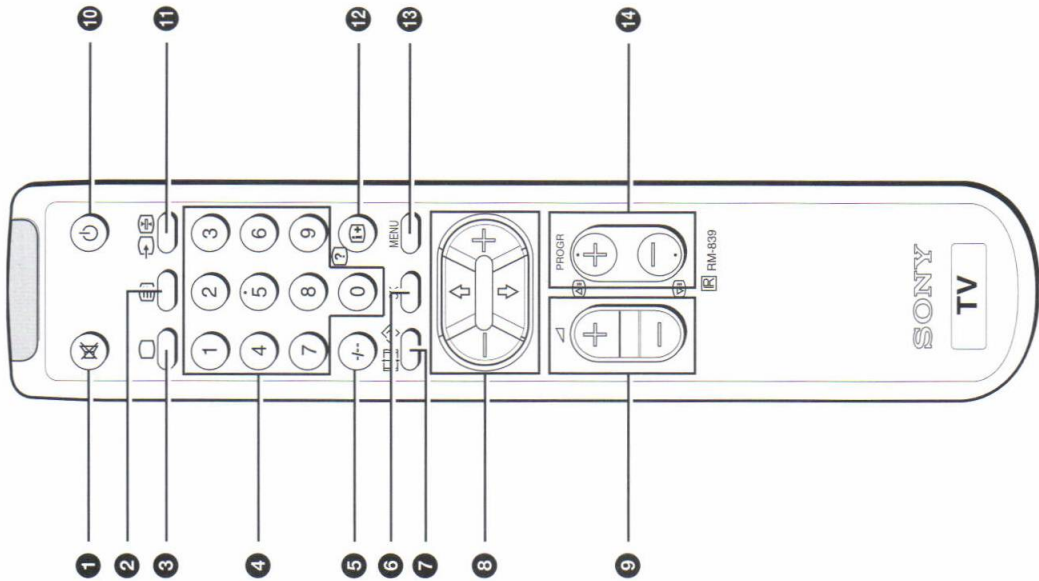
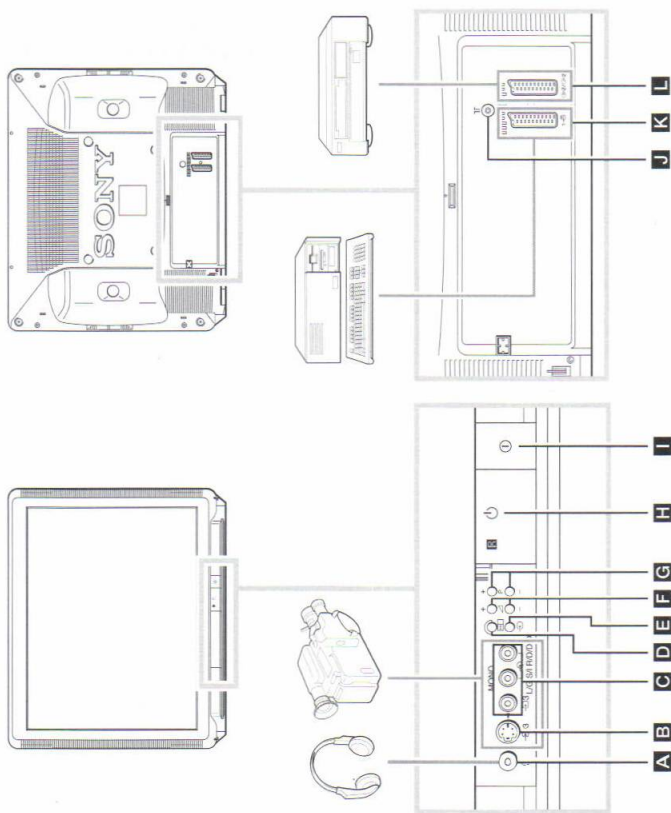













Free service manuals
 Gratis schema's
 Digitized by
www.freesevicemanuals.info









Overview**Overview**

This section briefly describes the controls and the buttons on the TV set and on the Remote Commander. Please open the flap at the front of the instruction manual for illustrations of the TV set and the Remote Commander. Letters in boxes refer to the buttons on the TV set, numbers in circles to the buttons on the Remote Commander. For more information, refer to the page numbers given next to each description.

TV buttons and Terminals

Reference and Symbol	Name	Refer to Page
Front of the set		
A 	Headphones jack	4
B 	S video input jack	29
C 	Audio/video input jacks	29
D 	Automatic Preset button	11
E 	Input mode button	13
F 	Volume control	12
G P 	Programme button	12
H 	Standby mode indicator	12
I 	Main power switch	12
Rear of the set		
J 	Aerial socket	10
K 	21 pin Euro connector	29
L 	21 pin Euro connector	29

Overview**Remote Commander Operation**

Reference and Symbol	Name	Refer to Page
1 	Muting on/off button	12
2 	Teletext button	13
3 	TV power on/TV mode button	12, 13
4 1, 2, ..., 9, 0	Number buttons	12
5 - / - -	Double digit entering button	12
6 OK	OK (Confirmation) button	14
7 	Screen format button Teletext: Favourite pages button	12, 28
8 	Menu control	14
9 	Volume control button	12
10 	Standby button	12
11 	Input mode button Teletext: Freezing the subpage	13, 27
12 	On-screen display button Teletext: reveal button	12, 27
13 MENU	Menu on/off button	14
14 PROGR +/-	Programme buttons Teletext: Page up / page down buttons	12, 13

Step 1

Connecting the Aerial (If you connect a VCR, skip to step 2)

Insert the aerial plug tightly into the aerial socket **1**. Use a good-quality aerial cable (not supplied), corresponding to the relevant regulations.

Step 2

Connecting a VCR

We recommend that you tune in the VCR signal to programme number "0". For details, see "Presetting Channels Manually" on page 16. See "Connecting Optional Equipment" on page 29 for more information.

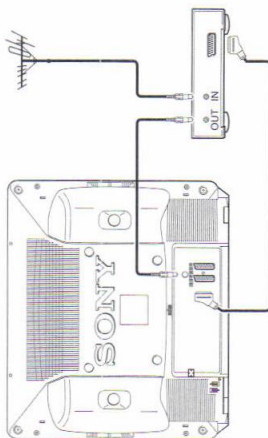

Step 3

Inserting the Batteries Into the Remote Commander

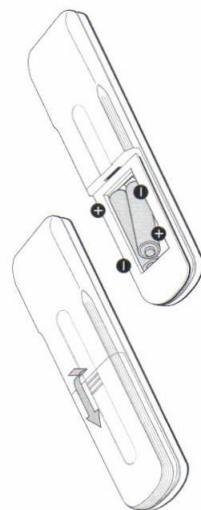

Respect your environment! Dispose of used batteries in an environmentally friendly way.

Step 4

Presetting Channels Automatically

With this function, the TV can automatically search and store up to 100 different channel numbers. If you prefer manual presetting, refer to "Presetting Channels Manually" on page 16.

- 1** Plug into mains. Press the power switch **1** on the TV set.
 - 2** Press and hold the button **2** on the TV set until the automatic menu is displayed and the search starts.
- After all available channels are stored, the normal TV picture is shown.

Note: Channels are automatically stored as follows;

KV-25X1U/29X1U	KV-25X1L/29X1L
Programme 1 BBC1	Programme 1 RTE1
Programme 2 BBC2	Programme 2 RTE2
Programme 3 ITV	Programme 3 BBC1
Programme 4 CH4 or S4C	Programme 4 BBC2
	Programme 5 ITV
	Programme 6 CH4 or S4C

Free service manuals
Gratis schema's
Digitale programme

www.freesevicemanuals.info

TV Operation

This section explains functions used whilst watching TV. Most operations are carried out using the remote commander (numbers in circles). All basic functions are also available on the TV set (letters in boxes). Open the flap at the front of the Instruction Manual to see the illustrations of the Remote Commander and the TV set.

TV Operation

To	Press
Switch on	① I on TV
Switch off temporarily	⏻ 10 TV is now in standby mode and H indicator on TV lights up.
Switch on from standby mode	□ 3 , PROGR +/- 14 G or any number button 4 .
Switch off completely	① I on TV To save energy, switch off your TV completely when TV is not in use.
Select programmes	PROGR +/- 14 G or number buttons 4 For double digit number, press -/- 5 then the number e.g. For 23, press -/- 5 then 2 and 3.
Display on screen indications	i+ 12 . Press again to make the indications disappear.
Adjust the volume	△ + or - 9 F
Mute the sound	⊗ 1 . Press again to restore the sound.
View programmes in 16:9 mode	⏏ 7 . Press again to return to 4:3 mode.

TV Operation (continued)

To	Press
View video input picture (see page 30 for detailed information)	↔ 1 E repeatedly until the desired video input appears. Press □ 3 to restore the TV picture.
View teletext (see page 27 for detailed information)	
Switch on	≡ 2
Select a page	three number buttons 4 or ⏏ 14 (for next page) or ⏏ 14 (for previous page).
Use fastext	Blue, Green, Red or Yellow 8 .
Switch off	□ 3

Adjusting and Setting the TV Using the Menu

You can adjust and set various functions on the TV using the following remote commander buttons:

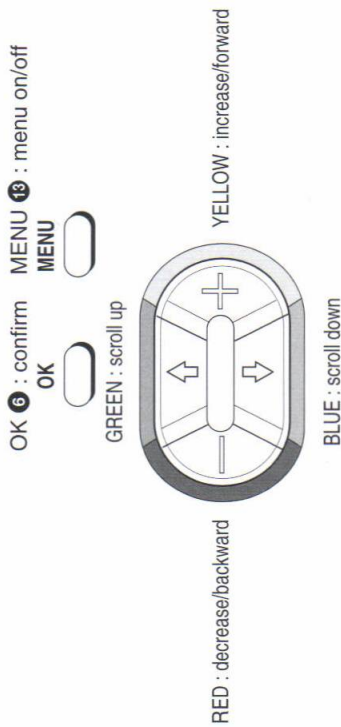

Choosing the Menu Language

This function enables you to change the language of the menu screens.

- 1 Press power switch **1** on the TV. If the standby indicator **1** on the TV is lit, press **3** or a number button **4** on the Remote Commander.
- 2 Press the MENU button **13** on the remote commander.

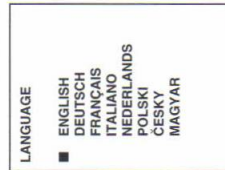

- 3 Press blue or green **8** to select the language you want then press yellow **8**.
- 4 Press the MENU button **13** to restore the normal TV picture.

Presetting Channels Automatically

You may have already preset the channels automatically by using the method shown on page 11. You can also preset channels automatically by using the remote commander as follows:



- 3 Press blue or green **8** to select 'AUTO PROGRAMME'.

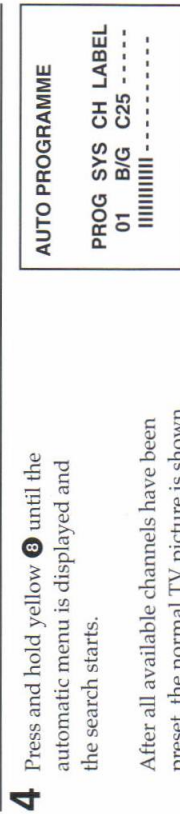

- 4 Press and hold yellow **8** until the automatic menu is displayed and the search starts.

After all available channels have been preset, the normal TV picture is shown.

Presetting Channels Manually

This function enables you to preset channels one by one to different programme numbers. This is also convenient for allocating programme numbers to various video input sources.

- 1 Press the MENU button **13**.
- 2 Press blue or green **8** to select the symbol  on the menu screen then press yellow **8**.



- 3 Press blue or green **8** to select 'MANUAL PROGRAMME' then press yellow **8**.

MANUAL PROGRAMME PRESET			
PROG	SYS	CHAN	LABEL AFT
1	B/G	C 1 ON
2	B/G	C 4 ON
3	B/G	C12 ON
4	B/G	C22 ON
5	B/G	C33 ON
6	B/G	C41 ON
7	B/G	C17 ON
8	B/G	C32 ON

- 4 Press blue or green **8** to select on which programme number you want to preset a channel then press yellow **8**.
- 5 Press blue or green **8** to select the TV broadcast system 'T' or a video input source (AV1,AV2 ...) then press yellow **8**.
- 6 **(This step 6 is only for KV-25X1L/29X1L)**
Press blue or green **8** to select 'C' (for terrestrial channels) or 'S' (for cable channels) then press yellow **8**.

- 7 Select the first number digit of 'CHAN' then the second number digit of 'CHAN' with the number buttons **4** on the remote commander
or
Press blue or green **8** to search for the next available channel number.

- 8 If you want to store the channel number, go to step 9. If not, select a new channel number using the number buttons **4** on the remote commander or press blue or green **8** to resume the search.
- 9 Press OK **6**.
- 10 Repeat steps 4 to 9 to preset other channels.
- 11 Press the MENU button **13** to restore the normal TV picture.

Adjusting the Picture and Sound

Although the picture and sound are adjusted at the factory, you can adjust them to suit your own taste.

1 Press the MENU button **18**.

2 Press blue or green **8**

to select **[PI]** for picture control or **[SI]** for sound control then press yellow **8**.

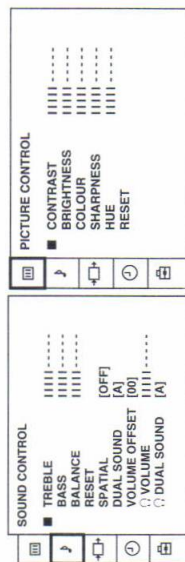

3 Press blue or green **8** to select the desired item then press yellow **8**.

4 Press red or yellow **8** to alter the item then press OK **6**.
For the effect of each control, see the following tables.

5 Repeat steps 3 and 4 to adjust the other items.

6 Press the MENU button **18** to restore the normal TV picture.

PICTURE CONTROL Effect

Contrast	Lower — — Higher
Brightness	Darker — — Brighter
Colour	Less — — More
Sharpness	Softer — — Sharper
Hue	Greenish — — Reddish (NTSC signals only)
Reset	Resets picture to the factory preset levels.

Adjusting the Picture and Sound (continued)

SOUND CONTROL Effect

Treble	Less — — More
Bass	Less — — More
Balance	Left — — Right
Reset	Resets sound to the factory preset levels.
Spatial	Acoustic sound effect.
Dual Sound	A: Left channel → B: Right channel → stereo → mono
Volume Offset	Presets the volume level for individual programmes. -12 — 0 — +12
Volume	Adjusts the headphone volume.
Dual Sound	Presets the headphone channels. A: Left channel → B: Right channel → stereo → mono

Manual Fine-Tuning

Normally, the automatic fine-tuning (AFT) function is operating. If the picture is distorted however, you can manually fine-tune the TV to obtain a better picture reception.

- 1 Press the MENU button **13**.
- 2 Press blue or green **8** to select the symbol  on the menu screen then press yellow **8**.

MANUAL PROGRAMME PRESET					
PROG	SYS	CHAN	LABEL	AFT	
1	B/G	C 1	----	ON	
2	B/G	C 4	----	ON	
3	B/G	C12	----	ON	
4	B/G	C22	----	ON	
5	B/G	C33	----	ON	
6	B/G	C41	----	ON	
7	B/G	C17	----	ON	
8	B/G	C32	----	ON	

- 3 Press blue or green **8** to select 'MANUAL PROGRAMME' then press yellow **8**.

- 4 Press blue or green **8** to select the programme number which corresponds to the channel you want to manually fine-tune.

- 5 Press yellow **8** repeatedly until the AFT position changes colour..

- 6 Press blue or green **8** to change the frequency of the channel from -15 to +15.

- 7 Press OK **6**.







- 8 Repeat steps 4 to 7 to fine-tune other channels.

- 9 Press the MENU button **13** to restore the normal TV picture.

Sorting Programme Positions

This function enables you to move channels to different programme numbers.

- 1 Press the MENU button **13**.
- 2 Press blue or green **8** to select the symbol  on the menu screen then press yellow **8**.

PRESET	
	AUTO PROGRAMME
	MANUAL PROGRAMME
	AV LABEL PRESET
	PROGRAMME SORTING
	PARENTAL LOCK
	LANGUAGE
	PICTURE ROTATION [00]

- 3 Press blue or green **8** to select 'PROGRAMME SORTING' then press yellow **8**.

PROGRAMME SORTING			
PROG	SYS	CHAN	LABEL
1	B/G	C23	BBC - 1
2	B/G	C28	RTL - -
3	B/G	C29	VHS - 1
4	B/G	C31	ZDF - -
5	B/G	C44	ITV - -
6	B/G	C14	SKY - -
7	B/G	C15	SAT - 1
8	B/G	C16	BBC - 2

- 4 Press blue or green **8** to select the channel you want to move to another programme number then press yellow **8**.

- 5 Press blue or green **8** to select the programme number to which you want to move the channel selected in step 4 then press yellow **8**.

- 6 Repeat steps 4 to 5 if you wish to move other channels to different programme numbers.

- 7 Press the MENU button **13** to restore the normal TV picture.

Using Parental Lock

This function enables you to prevent undesirable broadcasts from appearing on the screen. We suggest you use this function to prevent children from watching programmes which you consider unsuitable.

- 1 Press the MENU button **13**.
- 2 Press blue or green **8** to select the symbol  on the menu screen then press yellow **8**.
- 3 Press blue or green **8** to select 'PARENTAL LOCK' then press yellow **8**.



- 4 Press blue or green **8** to select the channel you want to block then press yellow **8**. The symbol  appears before the programme number to indicate that this channel is now blocked.

PROG	SYS	CHAN	LABEL
1	B/G	C23	BBC-1
2	B/G	C26	RTL
3	B/G	C29	VHS-1
4	B/G	C31	ZDF
5	B/G	C44	ITV
6	B/G	C14	SKY
7	B/G	C15	SAT-1
8	B/G	C16	BBC-2

- 5 Repeat step 4 if you wish to block other channels.
- 6 Press the MENU button **13** to restore the normal TV picture.

Note: To unblock, press yellow **8** after selecting the channel to unblock in the 'PARENTAL LOCK' menu.

Using the Sleep Timer

This function enables you to select a time period after which the TV automatically switches into standby mode.

- 1 Press the MENU button **13**.
- 2 Press blue or green **8** to select the symbol  on the menu screen then press yellow **8**.
- 3 Press yellow **8**.
- 4 Press red or yellow **8** to set time delay and press OK **6**.

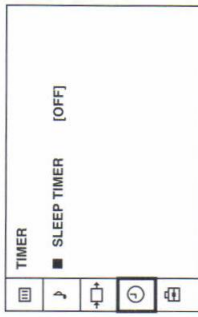

- OFF 0:30 1:00 1:30 3:30 4:00
- One minute before the TV switches into standby mode, a message is displayed on the screen.
- 5 Press the MENU button **13** to restore the normal TV picture.

Adjusting the Picture Rotation

If, due to the earth magnetism, the picture slants, you can use the function 'Picture Rotation' to readjust the picture.

- 1 Press the MENU button **13**.
- 2 Press blue or green **8** to select the symbol  on the menu screen then press yellow **8**.
- 3 Press blue or green **8** to select 'PICTURE ROTATION' then press yellow **8**.
- 4 Press red or yellow **8** to adjust the picture rotation then press OK **6**. The adjusting range is -5 to +5.
- 5 Press the MENU button **13** to restore the normal TV picture.



Skipping Programme Positions

This function enables you to skip unused channels when selecting programme numbers with the PROG+/- buttons. However, you can still watch the skipped channel(s) by using the number buttons.

- 1 Press the MENU button **13**.
- 2 Press blue or green **8** to select the symbol  on the menu screen then press yellow **8**.
- 3 Press blue or green **8** to select 'MANUAL PROGRAMME' then press yellow **8**.
- 4 Press blue or green **8** to select the channel you want to skip then press yellow **8**.
- 5 Press blue or green **8** until '---' appears in the 'SYS' position.
- 6 Press OK **6**.
- 7 Repeat steps 4 to 6 to skip other channels.
- 8 Press the MENU button **13** to restore the normal TV picture.

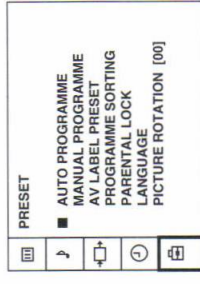

MANUAL PROGRAMME PRESET			
PROG	SYS	CHAN	LABEL AFT
1	B/G	C 1	----- ON
2	B/G	C 4	----- ON
3	B/G	C12	----- ON
4	B/G	C22	----- ON
5	B/G	C33	----- ON
6	B/G	C41	----- ON
7	B/G	C17	----- ON
8	B/G	C32	----- ON

Captioning a Station Name

Names for channels are usually automatically taken from teletext if available. You can however name a channel or an input video source using up to five characters (letters or numbers).

- 1 Press the MENU button **13**.
- 2 Press blue or green **8** to select the symbol  on the menu screen then press yellow **8**.
- 3 Press blue or green **8** to select 'MANUAL PROGRAMME' then press yellow **8**.

PRESET	AUTO PROGRAMME
	MANUAL PROGRAMME
	AV LABEL PRESET
	PROGRAMME SORTING
	PARENTAL LOCK
	LANGUAGE
	PICTURE ROTATION [00]
- 4 Press blue or green **8** to select the channel you wish to caption then press yellow **8** repeatedly until the first element of the 'LABEL' position is highlighted.
- 5 Press **8** blue or green to select a letter or number and press yellow **8** (select '.' for a blank).
Select other characters in the same way.

MANUAL PROGRAMME PRESET			
PROG	SYS	CHAN	LABEL AFT
1	B/G	C 1 ON
2	B/G	C 4 ON
3	B/G	C12 ON
4	B/G	C22 ON
5	B/G	C33 ON
6	B/G	C41 ON
7	B/G	C17 ON
8	B/G	C32 ON
- 6 After selecting all the characters, press OK **6**.
- 7 Repeat steps 4 to 6 to caption names for other channels.
- 8 Press the MENU button **13** to restore the normal TV screen.

Teletext

Most TV channels broadcast information via teletext. The index page of the broadcaster (usually page 100) gives you information on how to use the service.
Make sure you use a TV channel with a strong signal, otherwise teletext errors may occur.

Switching Teletext On and Off

- 1 Select the channel which carries the teletext service you wish to view.
- 2 Press **2** to display teletext.
If no teletext signal is broadcast, the indication P100 is displayed on a black screen.
- 3 Input three digits for the page number using the number buttons **4**.
The page counter searches for the page and after some seconds the page is displayed.
- 4 Press **3** to return to the normal TV picture.

Using Other Teletext Functions

To	Press
Access the next or preceding teletext page	14 for the next page or 14 for the preceding page
Mix the mode	2 when in teletext mode. Now the teletext page is superimposed on the TV programme. Press again to return to the normal teletext display.
Freeze a teletext subpage	11 . Press once again to cancel.
Reveal hidden information (eg: answers to a quiz)	12 . Press once again to cancel.

Favourite page system

You can store up to four of your favourite teletext pages per Teletext service. In this way you have quick access to the pages you frequently use.

Storing pages

- 1 Use the number buttons **4** to select the page you would like to store.
 - 2 Press **↔** **7** twice.
The colour prompts at the bottom of the screen flash.
 - 3 Press red, green, blue or yellow to store the selected page.
The page is now stored on this colour.
- Repeat steps 1 to 3 for the other 3 pages.

Displaying the Favourite Pages

- 1 Press **↔** **7**.
 - 2 Press blue, green, red or yellow to select the desired page.
- Make sure you press **↔** **7**, otherwise the normal Fastext facility operates.

Using Fastext

(only available, if the TV station broadcasts Fastext signals)

With Fastext you can access pages with one key stroke . When Fastext is broadcast, a colour-coded menu appears at the bottom of the screen. The colours of this menu correspond to the red, green, yellow and blue colours on the Remote Commander.

Press the Remote Commander colour button that corresponds to the colour-coded menu. The selected page is displayed after some seconds.

Connecting Optional Equipment

There is a wide range of optional equipment you can connect to your TV. Refer to the illustrations on the front flap page of this manual.

Symbol	Acceptable input signals	Available output signals
↔ 3, ↔ 3 B ↔ 3 C	Normal audio/video and S video	No output
↔ 1 K	Normal audio/video and RGB	Audio/video from TV tuner
↔ 2/ ↔ 2 L	Normal audio/video and S video	Audio/video from selected source

About S video input

Video signals may be separated into Y (luminance) and C (chrominance) signals. Separating the two signals prevents interference and thus improves the picture quality.

Notes on connections:

If the picture or sound is distorted, move the VCR away from the TV.

When connecting a monaural VCR, connect only the white jack to both the TV and VCR.

Selecting Input and Output Signals

This section explains how to select the output signal from **2/3** and how to select and view the input. You can use direct access buttons **1** to **3** to select the input or the menu system to select input and output.

Selecting With Direct Access Buttons

Press **1** repeatedly.
Press **2** to restore the normal TV picture.

Symbol on the screen	Input Signal
1	Audio/video through Euro AV connector K
2	RGB through Euro AV connector K
2	Audio/video through Euro AV connector L
3	S video through Euro AV connector L
3	Audio/video through the phono jacks C
3	S video through the phono jacks B

Selecting With the Video Connection Menu

- 1 Press the MENU button **13**.
- 2 Press blue or green **8** to select **VIDEO CONNECTION** then press yellow **6**.
- 3 Press blue or green to select input or output then press yellow **6**.
- 4 Press blue or green repeatedly to select the desired input or output source then press OK **6**.
- 5 Press the MENU button **13** to restore the normal TV picture.

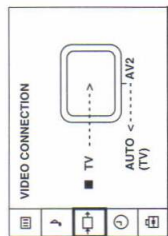

Note: If you select 'AUTO' for output, the output source automatically becomes the same as the desired input source.

Using AV Label Preset

This function enables you to label the input sources using up to five characters (letters or numbers).

- 1 Press the MENU button **13**.
- 2 Press blue or green **8** to select the symbol **AV** on the screen then press yellow **6**.
- 3 Press blue or green **8** to select 'AV LABEL PRESET' then press yellow **6**.
- 4 Press blue or green **8** to select the desired input source then press yellow **6**.
- 5 Press blue or green **8** to select a letter or number then press yellow **6** (select '-' for a blank).
Select other characters in the same way.
- 6 After selecting all the characters, press OK **6**.
- 7 Repeat steps 4 to 6 to label other input sources.
- 8 Press the MENU button **13** to restore the normal TV screen.

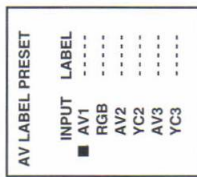

Free service manuals
Gratis schema's
Digitized by

www.freeservicemanuals.info

Troubleshooting

Here are some simple solutions to the problems which affect the picture and sound.

Problem	Solution
No picture (screen is dark), no sound	<ul style="list-style-type: none"> • Plug the TV in. • Press 0 1 on the TV. (If U indicator H is on, press 0 3 or a programme number 4 on the Remote Commander.) • Check the aerial connection. • Check if the selected video source is on. • Turn the TV off for 3 or 4 seconds then turn it on again using 0 1.
Poor or no picture (screen is dark), but good sound	<ul style="list-style-type: none"> • Press MENU 3 to enter the 'PICTURE CONTROL' menu and adjust 'Contrast', 'Brightness' and 'Colour'.
Poor picture quality when watching an RGB video source.	<ul style="list-style-type: none"> • Press ↔ 1 E repeatedly to select ↔.
Good picture but no sound	<ul style="list-style-type: none"> • Press ↙ + 9 F. • If 0x is displayed on the screen, press 0x 1.
No colour for colour programmes	<ul style="list-style-type: none"> • Press MENU 3 to enter the 'PICTURE CONTROL' menu, select 'Reset' then press OK 6.
Remote Commander does not function.	<ul style="list-style-type: none"> • Replace the batteries.

If you continue to have problems, have your TV serviced by qualified personnel. Never open the casing yourself.

SECTION 2 DISASSEMBLY

2-1. REAR COVER REMOVAL

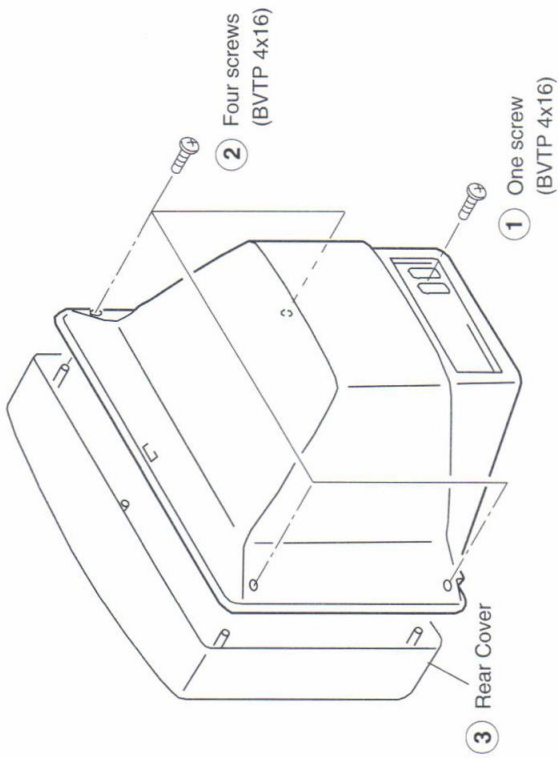

2-2. CHASSIS ASSY REMOVAL

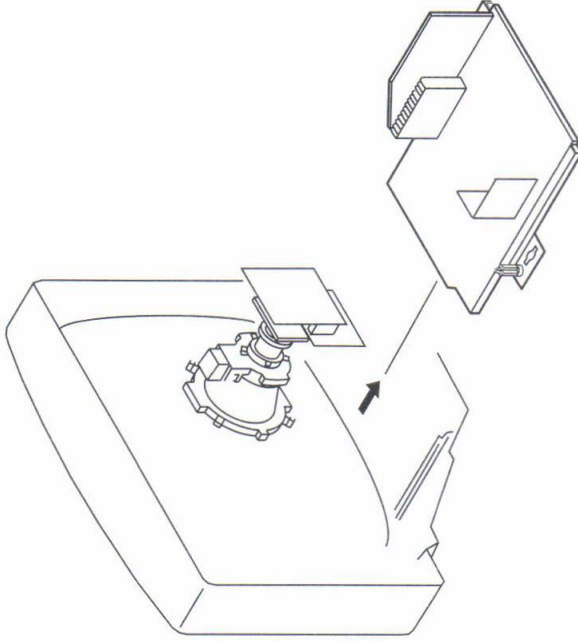

2-3. SERVICE POSITION

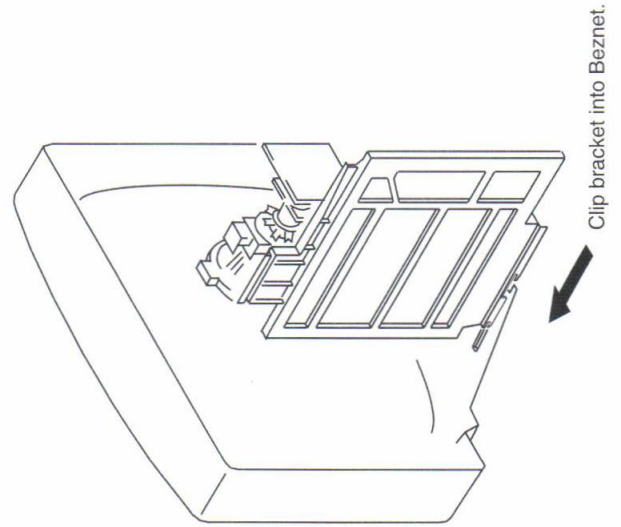

2-4. WIRE DRESSING

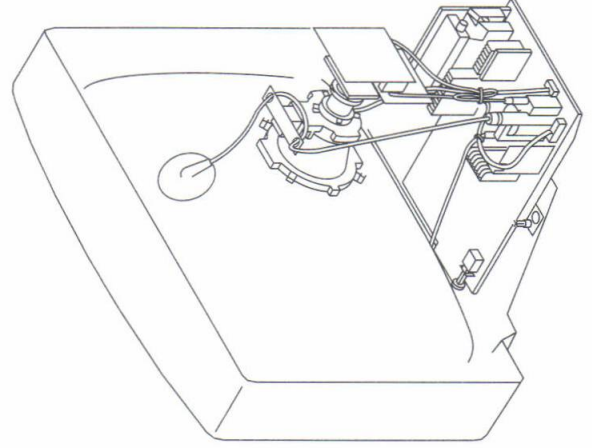

2-7. PICTURE TUBE REMOVAL

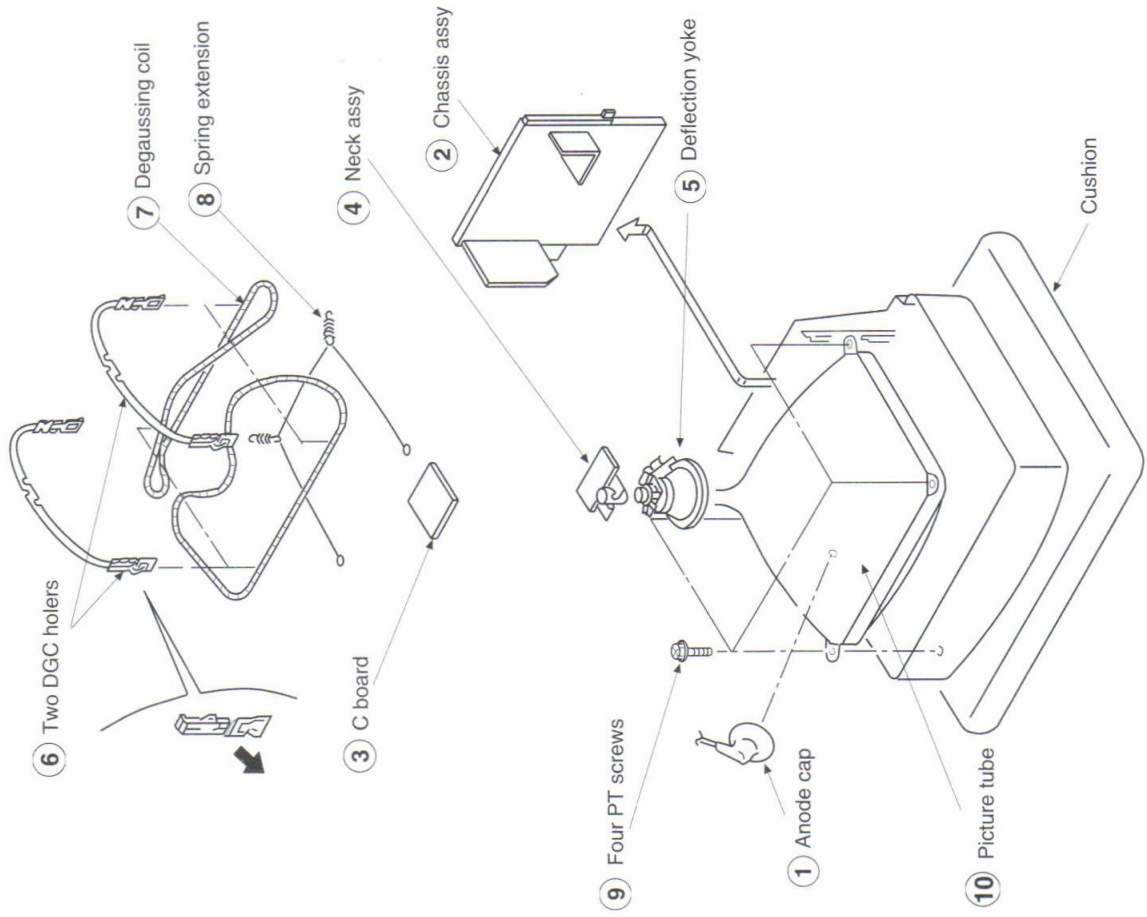

2-5. A BOARD REMOVAL

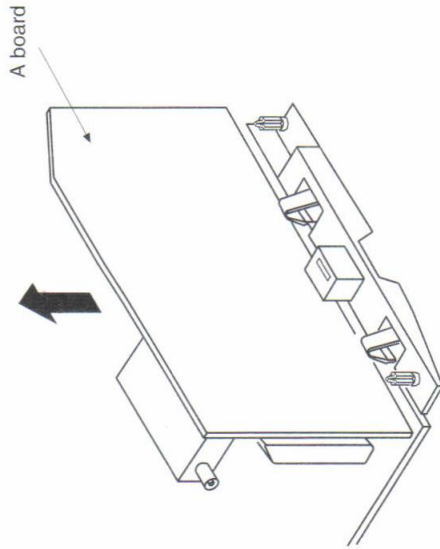

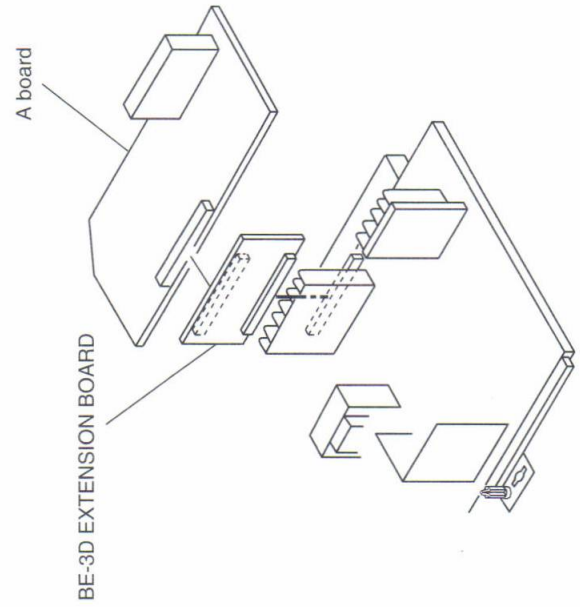

2-6. EXTENSION BOARD



• **REMOVAL OF ANODE-CAP**

Note: Short circuit the anode of the picture tube and the anode cap to the metal chassis, CRT shield or carbon paint on the CRT, after removing the anode.

• **REMOVING PROCEDURES.**

- 
- 
- 
- ① Turn up one side of the rubber cap in the direction indicated by the arrow ①
 - ② Using a thumb pull up the rubber cap firmly in the direction indicated by the arrow ②
 - ③ When one side of the rubber cap is separated from the anode button, the anode-cap can be removed by turning up the rubber cap and pulling it up in the direction of the arrow ③

• **HOW TO HANDLE AN ANODE-CAP**

- ① Don't damage the surface of anode-cap with sharp shaped material !
 - ② Don't press the rubber hardly not to hurt inside of anode-caps !
 - ③ A metal fitting called as shatter-hook terminal is built into the rubber. Don't turn the foot of rubber over hardly !
- The shatter-hook terminal will stick out or damage the rubber.

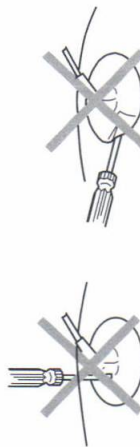

SECTION 3 SET - UP ADJUSTMENTS

- When complete readjustment is necessary or a new picture tube is installed, carry out the following adjustments.
- Unless there are specific instructions to the contrary, carry out these adjustments with the rated power supply.
- Unless there are specific instructions to the contrary, set the controls and switches to these settings :

- Contrast 80% (or remote control normal)
- ☼ Brightness 50%

- Carry out the following adjustments in this order :
 1. Beam landing
 2. Convergence
 3. Focus
 4. White balance

- Note:** Testing equipment required.
1. Color bar/pattern generator
 2. Degausser
 3. DC power supply
 4. Digital multimeter
 5. Oscilloscope

Preparation:

- In order to reduce the influence of geomagnetism on the set's picture tube, face it east or west.
- Switch on the set's power and degauss with the degausser.

3-1. BEAM LANDING

1. Input the white signal with the pattern generator.
 CONTRAST } normal
 BRIGHTNESS }
2. Position neck assy as shown in Fig.3-2.
3. Set the pattern generator raster signal to red.
4. Move the deflection yoke forward and adjust with the purity control so that the red is at the centre and the blue and the green take up equally sized areas on each side. (See Fig. 3-1 - 3-3)
5. Move the deflection yoke forward and adjust so that the entire screen becomes red. (See Fig. 3-1)
6. Switch the raster signal to blue, then to green and verify the condition.
7. When the position of the deflection yoke has been decided, fasten the deflection yoke with the screws.
8. If the beam does not land correctly in all the corners, use a magnet to adjust it. (See Fig. 3-4)

Fig. 3-2

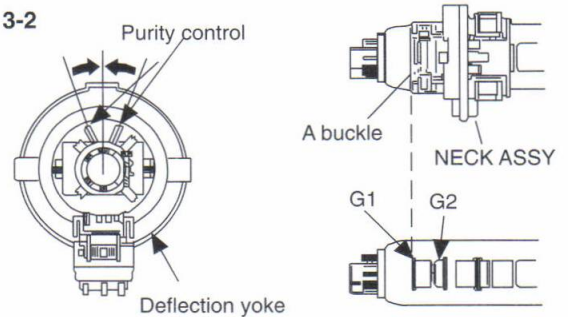

Fig. 3-3

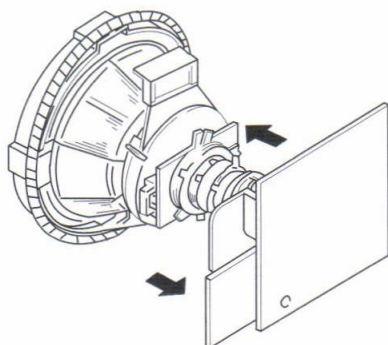
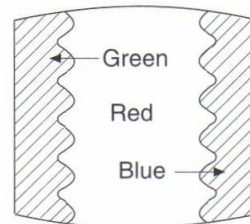

Fig. 3-1

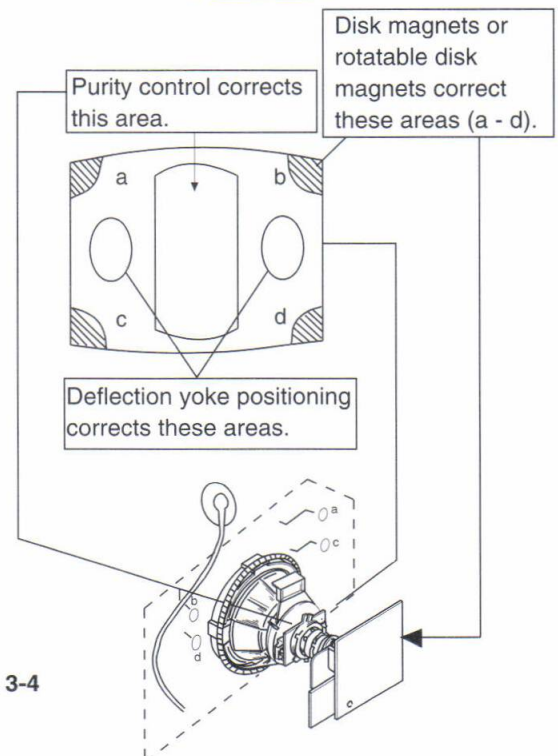

Fig. 3-4

3-2. CONVERGENCE

Preparation:

- Before starting this adjustment, adjust the focus, horizontal size, and vertical size.
- Minimize the brightness setting.
- Provide a dot pattern.

- Tilt the V.STAT magnet and adjust the static convergence by opening or closing the V.STAT magnet.

(1) Horizontal and vertical static convergence

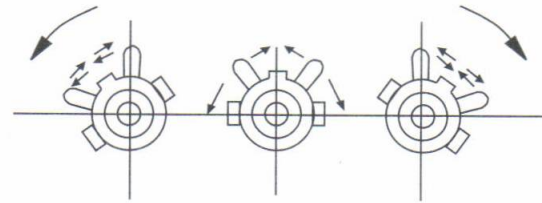
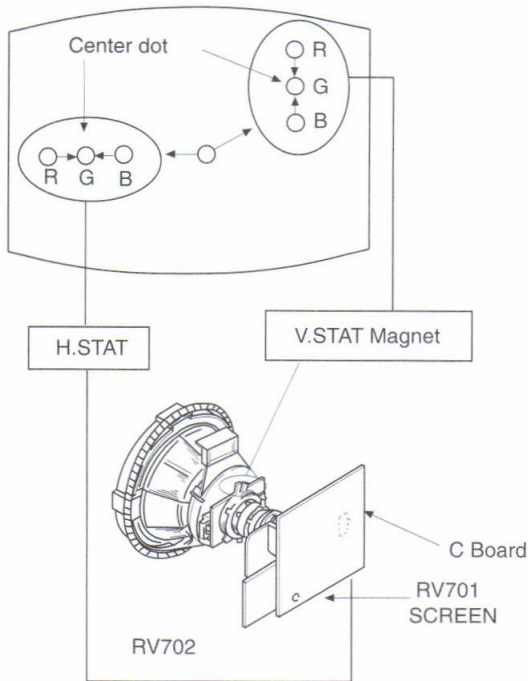

4. If the V.STAT magnet is moved in the direction of the (a) and (b) arrows, the red, green, and blue points move as shown below.

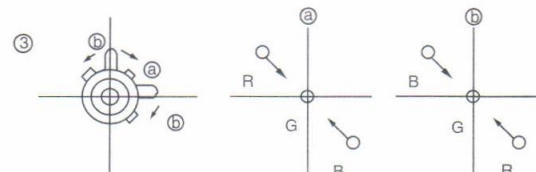
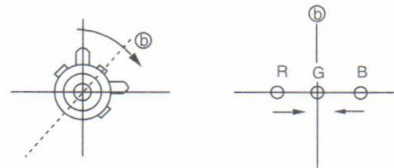
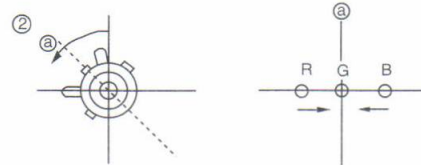
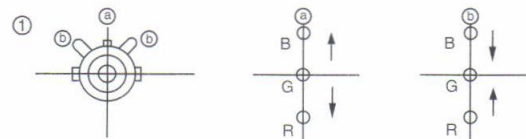

1. (Moving horizontally), adjust the H.STAT control so that the red, green, and blue points are on top of each other at the centre of the screen.
2. (Moving vertically), adjust the V.STAT magnet so that the red, green, and blue points are on top of each other at the centre of the screen.
3. If the H.STAT variable resistor cannot bring the red, green, and blue points together at the centre of the screen, adjust the horizontal convergence with the H.STAT variable resistor and the V.STAT magnet in the manner given below.
(In this case, the H.STAT variable resistor and the V.STAT magnet influence each other)

• Operation of BMC (Hexapole) Magnet

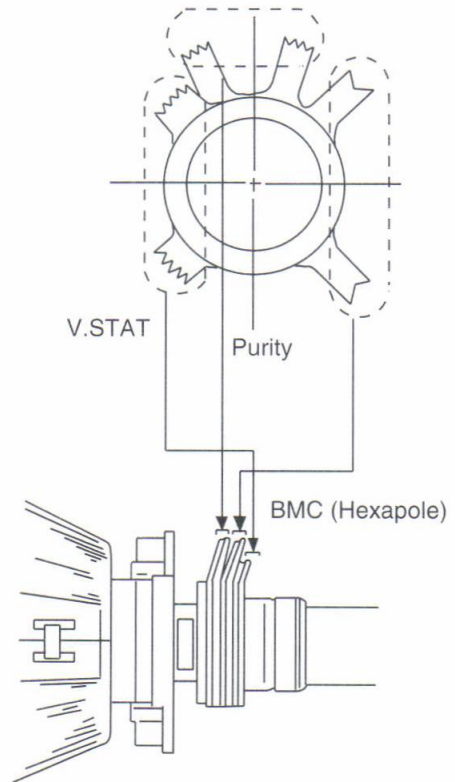
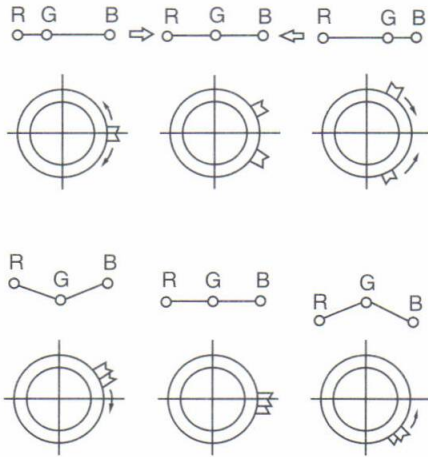

- The respective dot position resulting from moving each magnet interact, so be sure to perform adjustment while tracking.
Use the H.STAT VR to adjust the red, green, and blue dots so they coincide at the centre of the screen (by moving the dots in the horizontal direction).

(2) Dynamic convergence adjustment.

Preparation:

- Before starting this adjustment, adjust the horizontal static convergence and the vertical static convergence.
1. Slightly loosen the deflection yoke screws.

2. Remove the deflection yoke spacer.
3. Move the deflection yoke as shown in the figure below and optimize the convergence.
4. Tighten the deflection yoke screws.
5. Re-install the deflection yoke spacer.

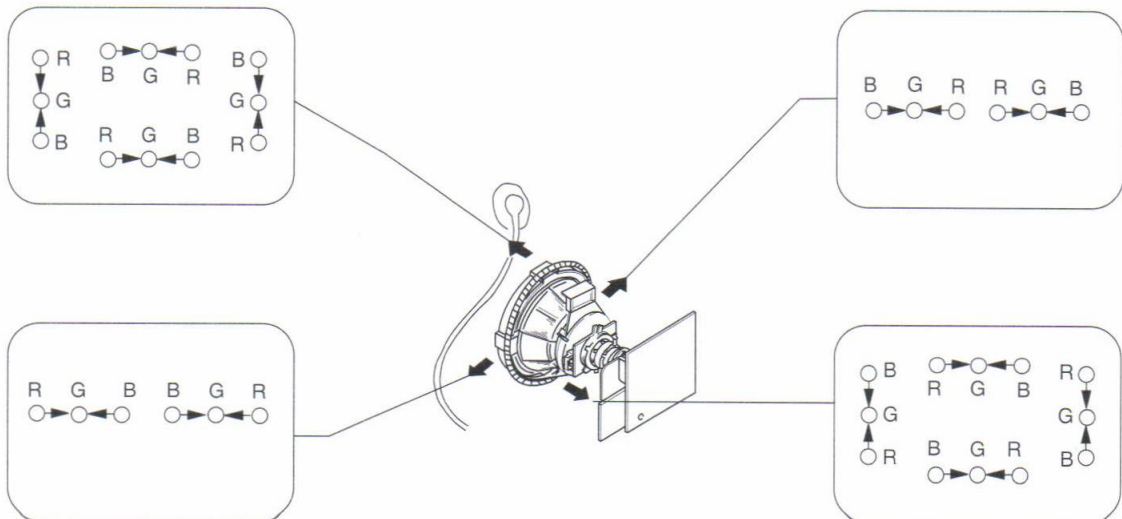

(3) Screen corner convergence.

If you are unable to adjust the corner convergence properly, correct them with the use of permalloy assemblies.

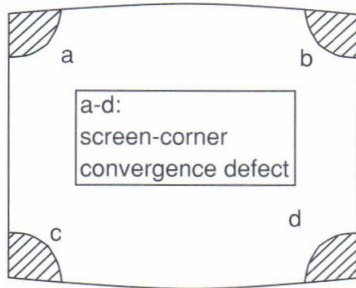

Install the permalloy assembly for the section with fault

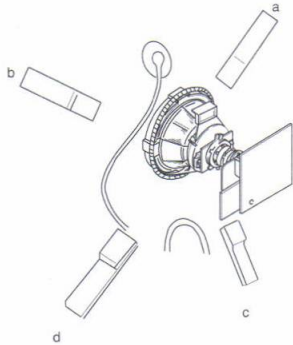

Permalloy

3-3. WHITE BALANCE

G2 Setting

1. Switch the set into AV mode (apply no signal to the AV connectors).
2. Connect a Volt Meter to Test Point 1 on the A board.
3. Adjust RV01 to obtain a voltage of 3.0V ±0.3V.

White balance adjustment

1. Input an all white signal from the pattern generator.
2. Enter into the service mode.
3. Enter into Picture Adjustment service menu.
4. Select sub-contrast and adjust to 7.
5. Select the Green Drive and adjust so that the white balance becomes optimum.
6. Select the Blue Drive and adjust so that the white balance becomes optimum.
7. Press the TV button to return to TV operation.

PICTURE ADJUSTMENT

AFC mode	1
REF position	2
SCP BGR	1
SCP BGF	1
Trap Fo	0
Sub contrast	Adj
Sub colour	Adj
Sub brightness	Adj
Sub hue	Adj
Green drive	Adj
Blue drive	Adj
Green cutoff	Adj
Blue cutoff	Adj
Gamma	0
Pre / overshoot	0
Y delay	3

SECTION 4

CIRCUIT ADJUSTMENTS

4-1. ELECTRICAL ADJUSTMENTS

Service adjustment to this model can be performed with the supplied remote commander RM-839.

HOW TO ENTER INTO SERVICE MODE

1. Turn on the main power switch of the set and enter into standby mode.
2. Press the following sequence of buttons on the Remote Commander.

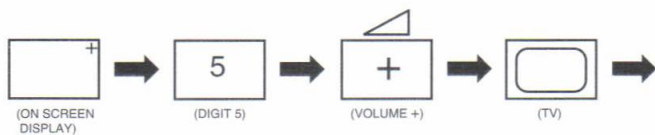

"TT--" will appear in the top right corner of the screen. Other status information will also be displayed.

3. Press MENU on the commander to obtain the following menu on the screen.

TEST MENU

> Picture adjustment
 Geometry
 Wide
 MSP
 IC status
 Current TV status

4. Move to the corresponding adjustment using the ↓ button on the commander.
5. Press the + button to enter the selected adjustment.
6. Turn off the power to quit the service mode when adjustments are completed.

PICTURE ADJUSTMENT

AFC mode	1
REF position	3
SCP BGR	1
SCP BGF	1
Trap Fo	7
Sub contrast	Adj
Sub colour	Adj
Sub brightness	Adj
Sub hue	Adj
Green drive	Adj
Blue drive	Adj
Green cutoff	Adj
Blue cutoff	Adj
Gamma	0
Pre / overshoot	0
Y delay	5

GEOMETRY ADJUSTMENT

V Size	Adj
V Position	Adj
S Correction	Adj
V Linearity	Adj
H Size	Adj
H Position	Adj
Pin Amp	Adj
Pin Phase	Adj
AFC Bow	Adj
AFC Angle	Adj
EHT V	Adj
EHT H	Adj
Corner Pin	Adj

WIDE

V Aspect	43
V Scroll	31
Upper V Lin	0
Lower V Lin	0
Left Blanking	1
Right Blanking	11

MSP

AGC ON/OFF	ON
Constant gain CDB	0
FM prescale FMP	36
Zwei mono-st WHI	36
Zwei st-mono WLO	18
Zwei mono-bi WMH	36
Zwei bi-mono WLO	18
Time zwei WML	41
Fawct limit	10
Fawct soll init FAW	12
Fawer tol	2
Nicam Err Max CCT	10
Nicam Err Min	0
Nicam Prescale NIP	97
Time Nicam	31
Carrier mute CRM	OFF
Audio clock ACO	HIZ
Scart prescale	25
Scart volume	64

IC STATUS (CXA2000 / CXA2040)

CXA2000

H lock	1
IKR	1
VNG	0
X-RAY	0
Colour system	3
CV1 Sync	1

CXA2040

Sync sep	1
S1 mode pin	01
S2 mode pin	01

TUNER

Tuner status	01101011
--------------	----------

TV STATUS

Text system	C TEXT/TV TEXT
Dolby	NO/YES
Text language set	WEST/EAST/RUSSIAN
Menu language set	WEST/EAST/RUSSIAN
Destination	B/D/U/K/L/E/A/R
Scart 16:9	OFF/ON
RGB priority	OFF/ON
Ageing	OFF/ON
Size	29/25
Colour trap sw	SECAM/ALL
Velocity mod	ON/OFF
AFT STATUS	WINDOW/HIGH/LOW

SUB BRIGHTNESS ADJUSTMENT

1. Input a Phillips pattern.
2. Set the picture control to minimum.
3. Enter into the Picture Adjustment Service Menu.
4. Adjust the Sub-Brightness data so that there is barely a difference between the 0 IRE and 10 IRE signal.

SUB CONTRAST ADJUSTMENT

1. Input a video that contains a small 100% area on a black background.
2. Set the picture control to maximum.
3. Connect an oscilloscope to pin 3 of CN301 (A board).
4. Enter into the Picture Adjustment Service Menu.
5. Adjust the Sub-contrast data to obtain a black to white amplitude of 2.50 volts.

SUB COLOUR ADJUSTMENT

1. Receive a PAL Colour Bar video signal.
2. Connect an oscilloscope to pin 3 of CN301 (A board).
3. Enter into the Picture Adjustment Service Menu.
4. Adjust the sub colour data so that cyan, magenta and blue colour bars are of equal height.

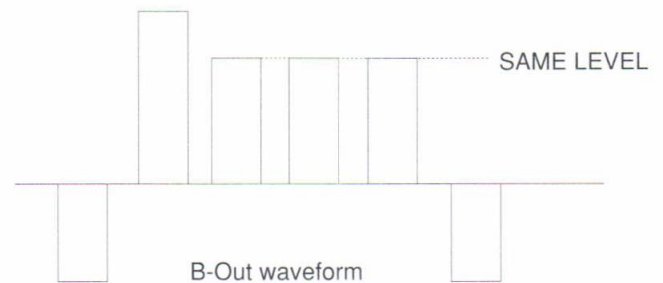

NOTE: The data shown in the TV STATUS table is dependant on destination, screen size and country.

SYSTEM B/G, D/K, I & L I.F ADJUSTMENT

1. Input an off air signal of between 60-100dBuV / 75 ohm terminated, via the tuner socket.
2. Enter into the I.F adjustment service mode (i.e. " TT 59 ") to fix the I.F frequency to 38.9 MHz.
3. Enter into the service mode and select "Current TVStatus".
4. Adjust the I.F coil (LV01) until the "AFT Status" indicates a " Window " condition.

SYSTEM L BAND 1 I.F ADJUSTMENT

1. Input an off air signal of between 60-100dBuV / 75 ohm terminated, via the tuner socket.
2. Enter into the I.F adjustment service mode (i.e. " TT 59 ") to fix the I.F frequency to 34.2 MHz.
3. Enter into the service mode and select "Current TVStatus".
4. Adjust the RV02 until the "AFT Status" indicates a " Window " condition.

TUNER AGC ADJUSTMENT

1. Receive a signal of 63dBuV / 75 ohm terminated via the tuner socket.
2. Measure the voltage at test point 1 (A board).
3. Adjust RV01 to obtain a voltage of 3.0V ± 0.3V.

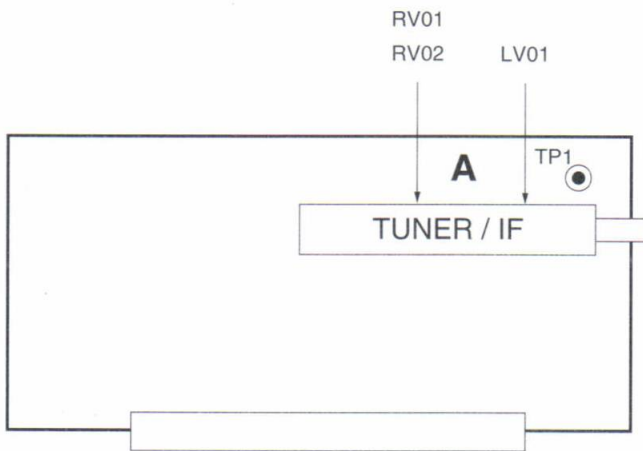

- A Board component side -

DEFLECTION SYSTEM ADJUSTMENT

1. Enter into the Geometry Adjustment Service Menu.
2. Select and adjust each item in order to obtain the optimum image.

GEOMETRY ADJUSTMENT

V Size	Adj
V Position	Adj
S Correction	Adj
V Linearity	Adj
H Size	Adj
H Position	Adj
Pin Amp	Adj
Pin Phase	Adj
AFC Bow	Adj
AFC Angle	Adj
EHT V	Adj
EHT H	Adj
Corner Pin	Adj

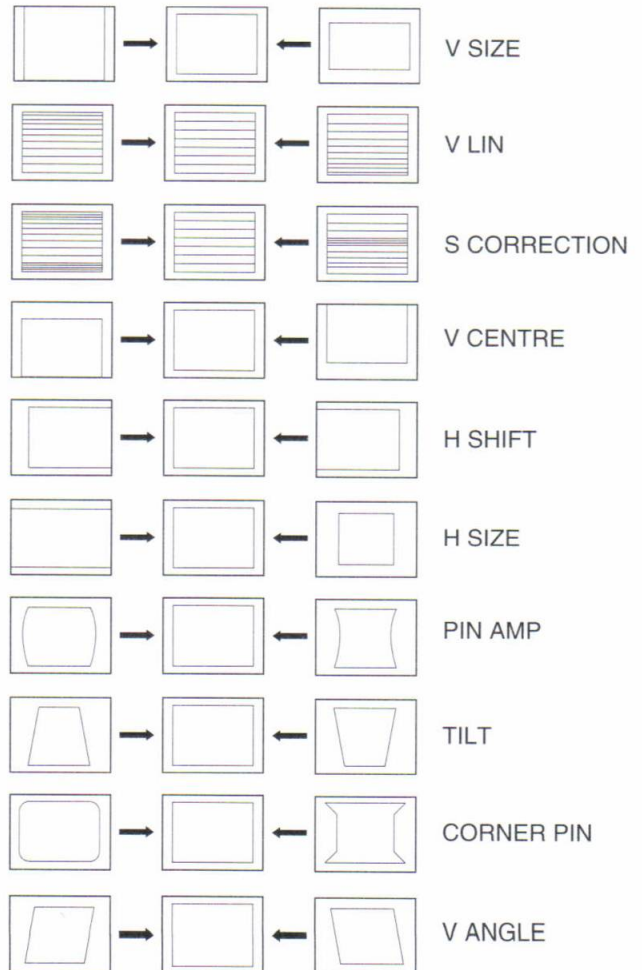

4-2. TEST MODE 2:

Is available by pressing Test button twice, OSD " TT " appears. The functions described below are available by pressing the two numbers. To release the Test mode 2, press 0 twice, or switch the TV into stand-by mode.

00	Switch test mode 2 off
01	Picture maximum
02	Picture minimum
03	Volume 30%
04	Set service menu mode
05	Set production menu mode
06	Volume 80%
07	Set ageing condition
08	Set shipping condition
09	Language reset
10	No function
11	Adjustment without OSD
12	Dummy
13	Display TV configuration
14	Forced AV 6:9 mode
15	Reset LPM from ROM data
16	copy LPM to reset memory
17	Preset label for AV sources
18	RGB priority on/off
19	Clear all preset labels
20	No function
21	Sub contrast
22	Sub colour
23	Sub brightness
24	Set destination = U
25	Set destination = D
26	Set destination = B
27	Set destination = K
28	Set destination = L
29	Set destination = E
30	No function
31	Set destination =A
32	Dummy
33	Auto AGC
34	Dummy
35	Manual AGC adjust

36-40	Dummy
41	Re-initialise NVM
42	Production use only
43	Initialise geometry settings
44	Initialise all favourite pages = 100
45	Channel locks = off
46	Dealer commander mode
47	Default MSP settings
48	Restore NVM test byte
49	Delete NVM test byte
50-60	No function
61	Turn on Dolby Pro Logic mode
62	White noise to left speaker
63	White noise to right speaker
64	White noise to centre speaker
65	White noise to rear speaker
66	Set standard stereo mode
67	Set Pro Logic normal mode
68	Set Pro Logic wide mode
69	Set Pro Logic phantom mode
70	No function
71	Picture rotation on/off
72	Dolby register settings
74	No function
75	Reset picture colour balance
76	Reset picture geometry
77	Reset sound settings
78	Reset error codes in the NVM
79-99	No function

4-3. BE-3D SELF DIAGNOSTIC SOFTWARE

The identification of errors within the BE-3D chassis is triggered in 1 of 2 ways :- 1: Bus busy or 2: Device failure to respond to IIC. In the event of one of these situations arising the software will first try to release the bus if busy (Failure to do so will report with continuous flashing LED) and then communicate with each device in turn to establish if a device is faulty. If a device is found to be faulty the relevant device number will be displayed through the led (Series of flashes which must be counted) See Table 1, non fatal errors are reported with this method.

Table 1

ERROR	LED ERROR COUNT
Protection circuit trip < ANY TIME >	02
IIC SCL LOW < POWER UP ONLY >	03
IIC SDA LOW < POWER UP ONLY >	04
IIC SDA & SCL LOW < POWER UP ONLY >	05
Jungle/Choroma controller no acknowledge < POWER UP ONLY >	06
Video Switch no acknowledge < POWER UP ONLY >	07
Tuner no acknowledge	08
MSP no acknowledge	09
NVM no acknowledge	10
M3L TXD LOW < POWER UP ONLY >	11
M3L RXD LOW < POWER UP ONLY >	12
M3L ENABLE LOW < POWER UP ONLY >	13
M3L TXD & RXD LOW < POWER UP ONLY >	14
Compact Text test fail < POWER UP ONLY >	15
AV switch cannot power on reset	16
Cannot initialise jungle	17
NVM acknowledge fail after initialisation	18
Multiple devices with no acknowledge < POWER UP ONLY >	19
Compacttext run-time failure	20
AVSWITCH response failure after power up	21
JUNGLE/CHROMA controller response failure after power up	22
CompactText does not respond	23

Flash Timing Example : e.g. error number 3.

Stby LED



SECTION 5
DIAGRAMS

KV-29C1 KV-29C1

KV-29C1 KV-29C1

KV-29C1

5-1. BLOCK DIAGRAM (1)

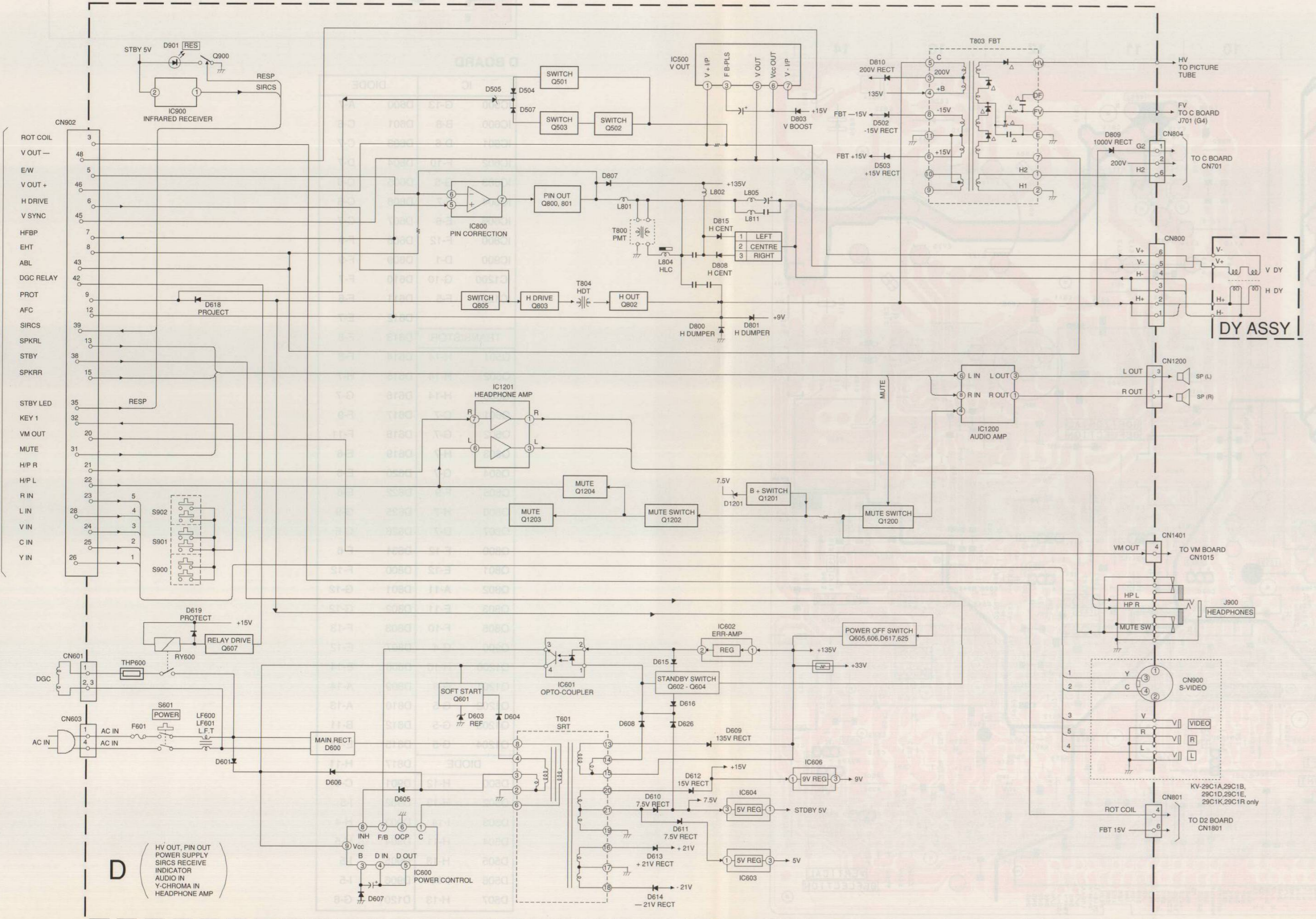

BLOCK DIAGRAM (2)

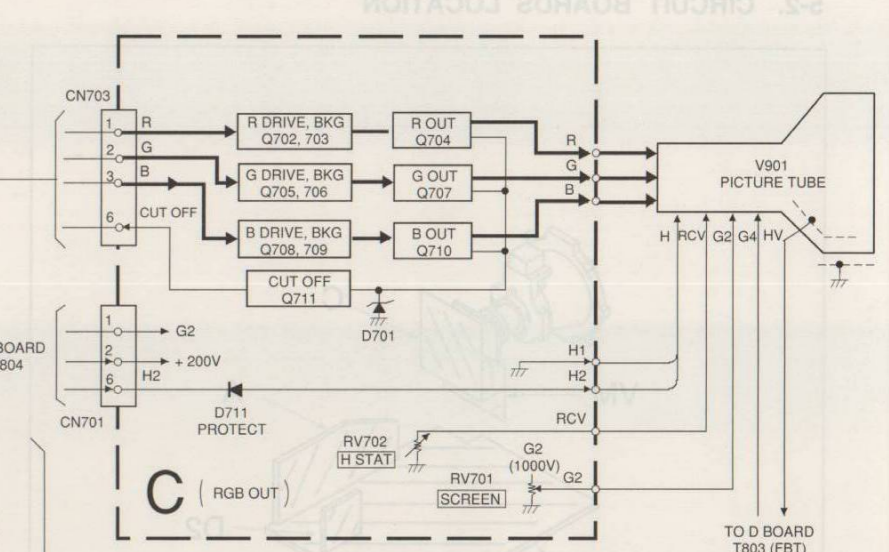
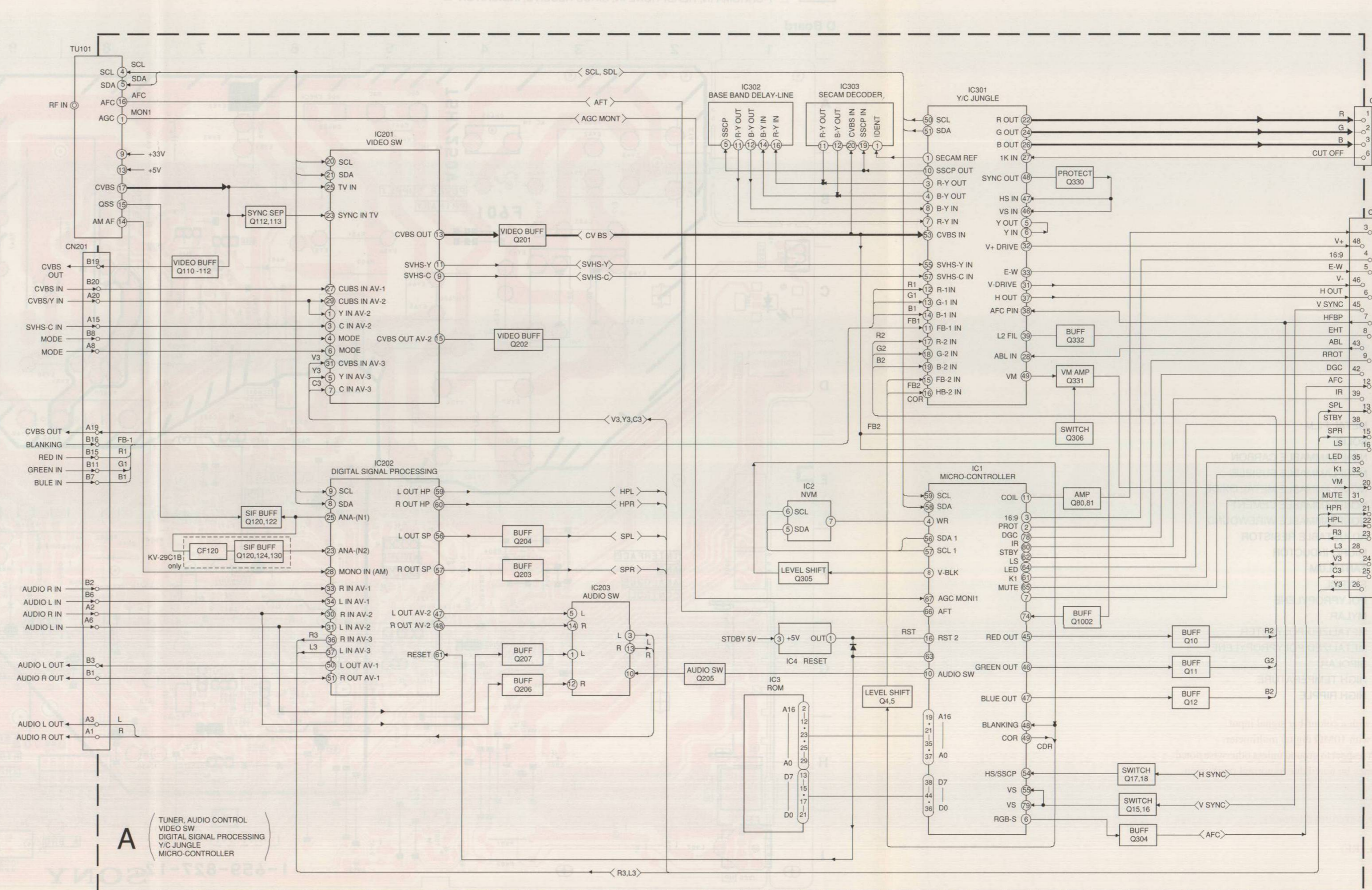

Free service manuals
Gratis schema's
Digitized by
www.freescvmanu.info

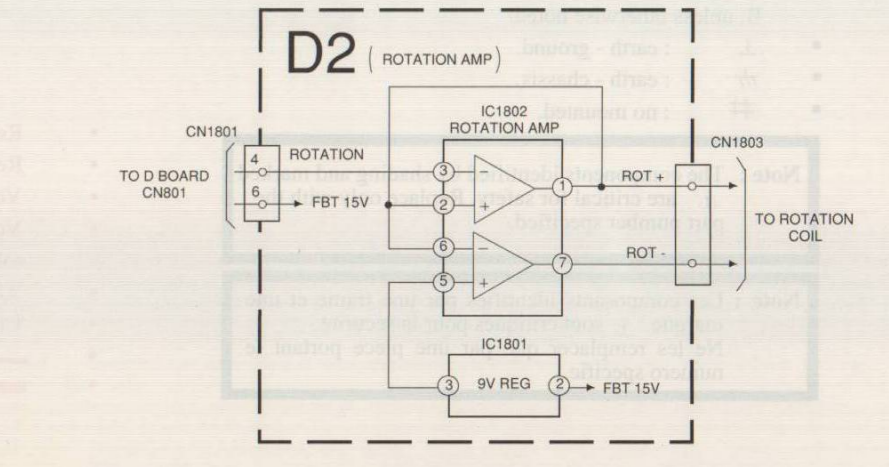
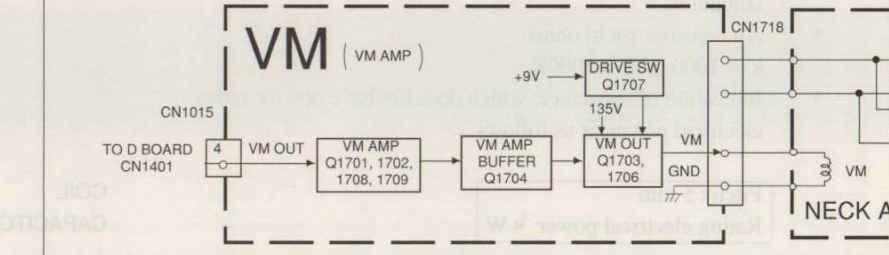

5-2. CIRCUIT BOARDS LOCATION

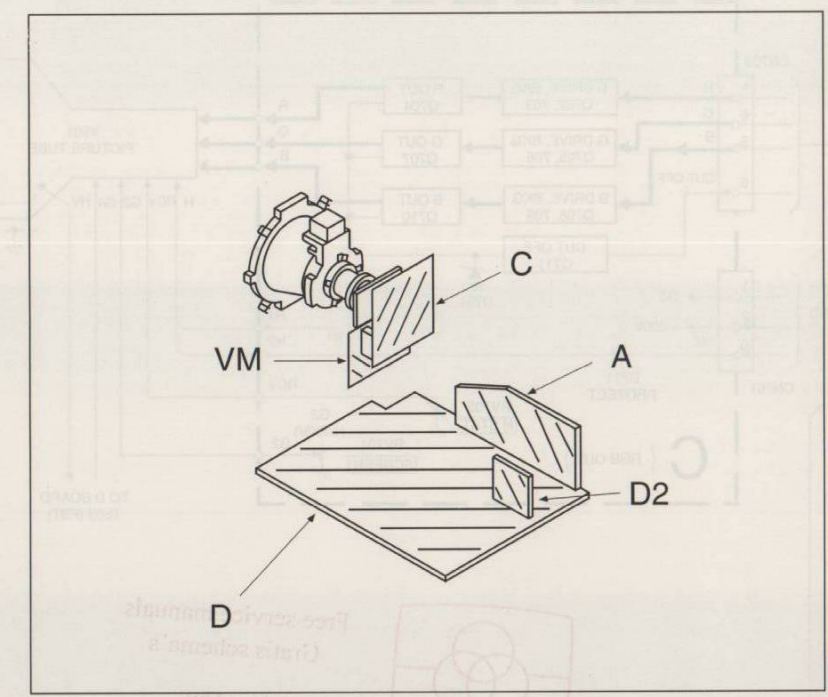

5-3. SCHEMATIC DIAGRAMS AND PRINTED WIRING BOARDS

- Note :**
- All capacitors are in μF unless otherwise noted. pF : μpF 50WV or less are not indicated except for electrolytic and tantalums.
 - All resistors are in ohms. $k = 1000$, $M = 1000K$
 - Indication of resistance, which does not have one for rating electrical power, is as follows.
- Pitch : 5 mm
Rating electrical power $\frac{1}{4}$ W
- : nonflammable resistor.
 - : internal component.
 - : panel designation, or adjustment for repair.
 - All variable and adjustable resistors have characteristic curve B, unless otherwise noted.
 - \perp : earth - ground.
 - $\text{---}\perp$: earth - chassis.
 - $\#$: no mounted.

Reference information

RESISTOR	: RN	METAL FILM
	: RC	SOLID
	: FPRD	NONFLAMMABLE CARBON
	: FUSE	NONFLAMMABLE FUSIBLE
	: RS	NONFLAMMABLE METAL OXIDE
	: RB	NONFLAMMABLE CEMENT
	: RW	NONFLAMMABLE WIREWOUND
	: X	ADJUSTABLE RESISTOR
COIL	: LF-8L	MICRO INDUCTOR
CAPACITOR	: TA	TANTALUM
	: PS	STYROL
	: PP	POLYPROPYLENE
	: PT	MYLAR
	: MPS	METALIZED POLYESTER
	: MPP	METALIZED POLYPROPYLENE
	: ALB	BIPOLAR
	: ALT	HIGH TEMPERATURE
	: ALR	HIGH RIPPLE

- Readings are taken with a colour-bar signal input.
- Readings are taken with 10M Ω digital multimeter.
- Volatges are dc with respect to ground unless otherwise noted.
- Voltage variations may be noted due to normal production tolerances.
- All voltages are in V.
- Circled numbers are waveform references.
- : B+ bus.
- : signal path. (RF)

Note : The components identified by shading and marked \perp are critical for safety. Replace only with the part number specified.

Note : Les composants identifies par une trame et une marque \perp sont critiques pour la securite. Ne les remplacer que par une piece portant le numero specifique.

D HV OUT, PIN OUT, POWER SUPPLY, CONTROL SW, AUDIO IN Y-CHROMA IN, HEADPHONE IN, SIRCS RECEIVE, INDICAITON

D Board

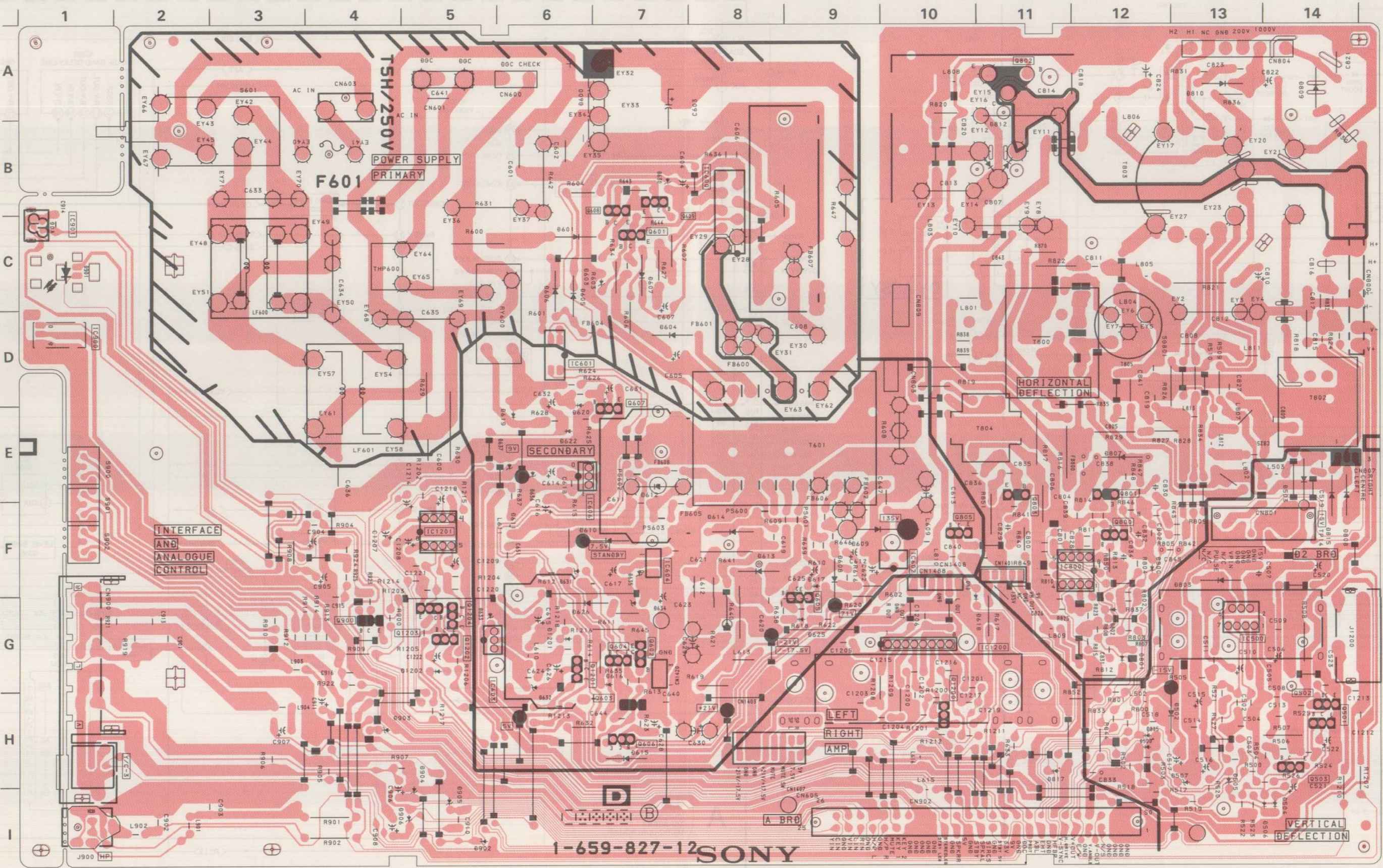

NOTE:
The circuit indicated as left contains high voltage of over 600 Vp-p. Care must be paid to prevent an electric shock in inspection or repairing.

D BOARD

IC		DIODE	
IC500	G-13	D600	A-7
IC600	B-8	D601	C-6
IC601	D-6	D603	C-7
IC602	F-10	D604	D-7
IC603	G-5	D605	C-6
IC604	F-7	D606	C-6
IC800	F-12	D608	F-9
IC900	D-1	D609	F-9
IC1200	G-10	D610	F-7
IC1201	F-5	D611	F-6
		D612	E-7
		D613	F-8
TRANSISTOR			
Q501	H-14	D614	F-8
Q502	H-14	D615	H-7
Q503	H-14	D616	G-7
Q601	C-7	D617	F-9
Q602	G-7	D618	F-11
Q603	H-7	D619	E-6
Q604	G-7	D620	E-6
Q605	F-9	D622	E-6
Q606	H-7	D625	G-9
Q607	D-7	D626	G-6
Q800	F-12	D631	F-6
Q801	E-12	D800	F-12
Q802	A-11	D801	G-12
Q803	E-11	D802	G-12
Q805	F-10	D803	F-13
Q900	G-4	D807	E-12
Q1200	H-10	D808	E-14
Q1201	G-6	D809	A-14
Q1202	G-5	D810	A-13
Q1203	G-5	D812	B-11
Q1204	G-5	D815	E-14
DIODE			
D500	H-12	D901	C-1
D502	H-13	D902	I-5
D503	I-14	D903	H-4
D504	H-11	D904	H-5
D505	H-13	D905	I-5
D506	I-14	D906	I-5
D507	H-13	D1201	G-6

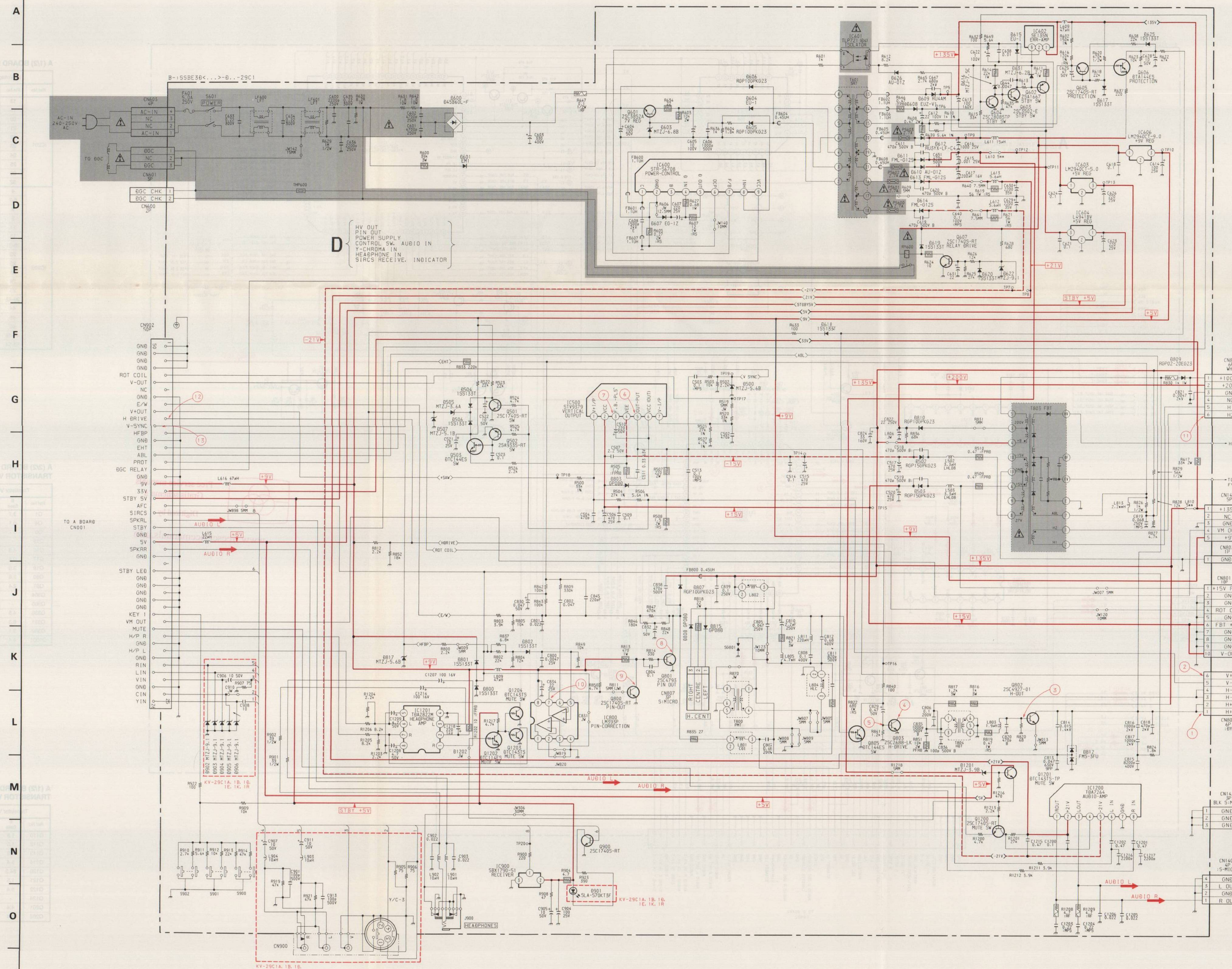

WAVEFORMS D BOARD

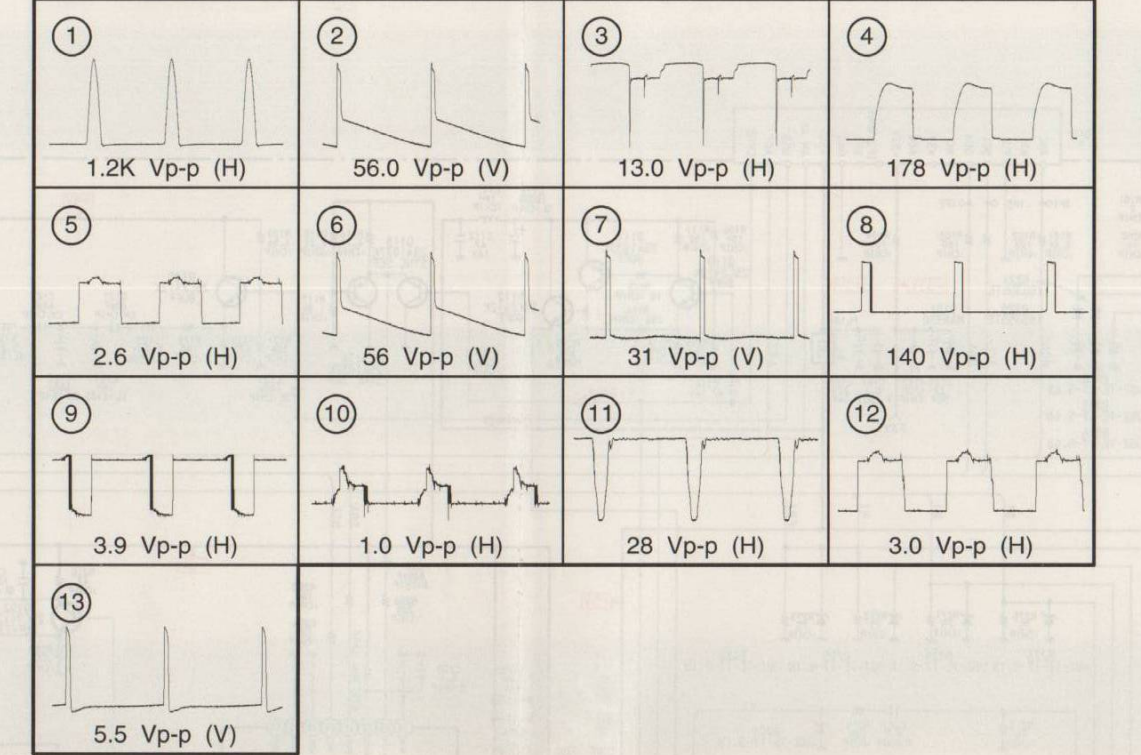

D BOARD TRANSISTOR VOLTAGE TABLE

Table with 4 columns: Ref No, B (Base), C (Collector), E (Emitter). Lists voltage levels for various transistors like Q501, Q502, etc.

D BOARD IC VOLTAGE TABLE

Table with 3 columns: Ref No, Pin No, Voltage (V). Lists voltage levels for various ICs like IC500, IC600, etc.

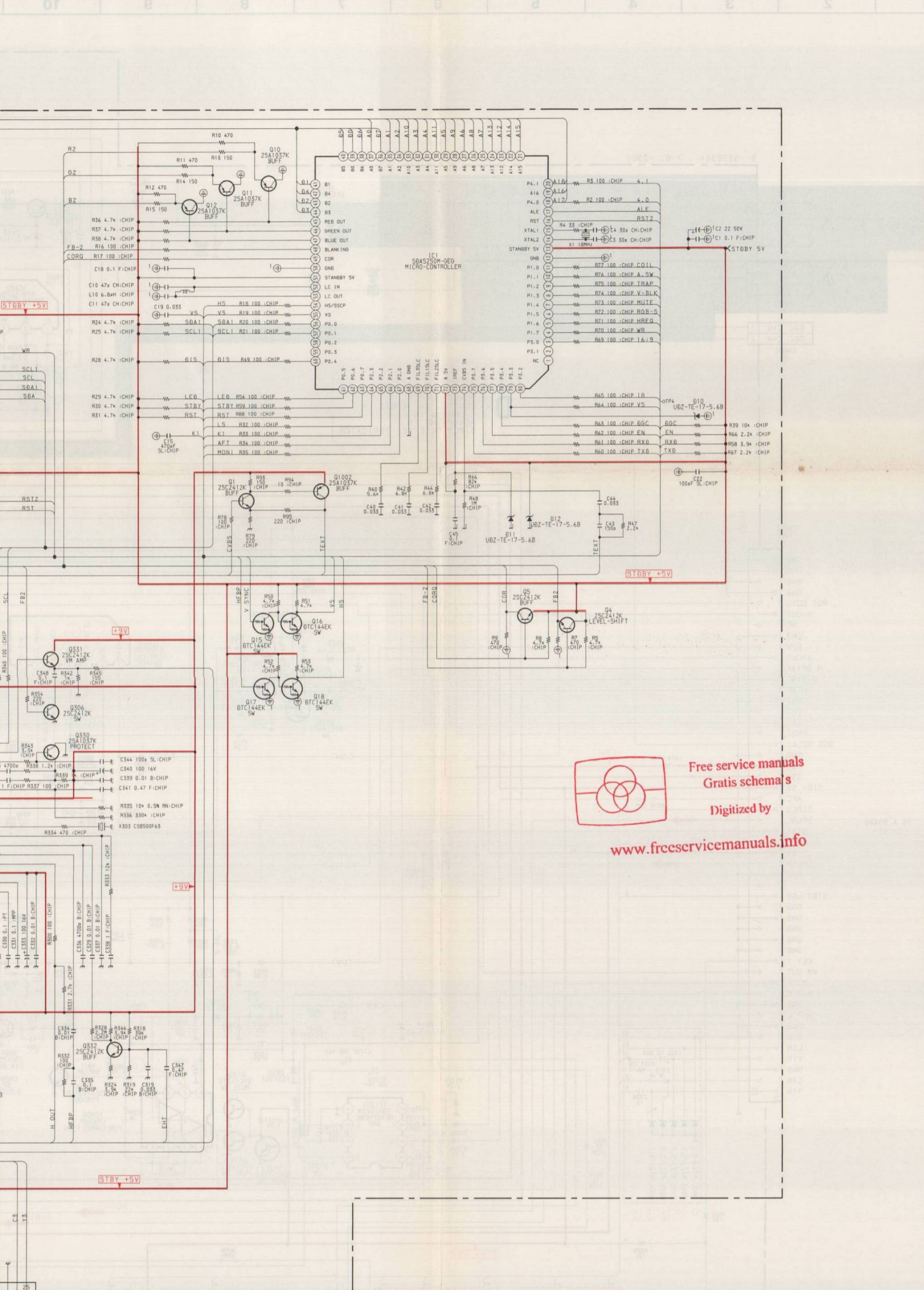
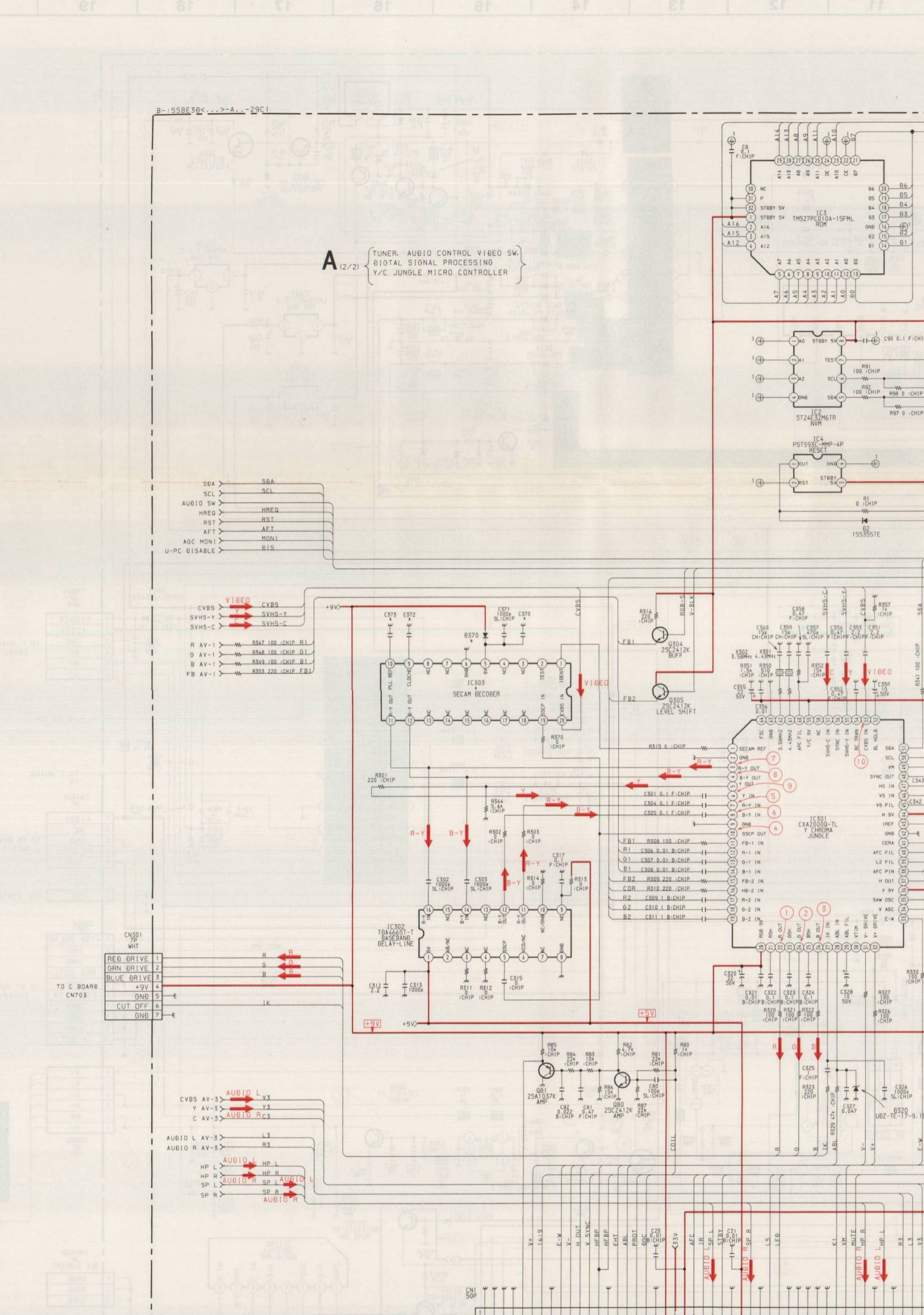
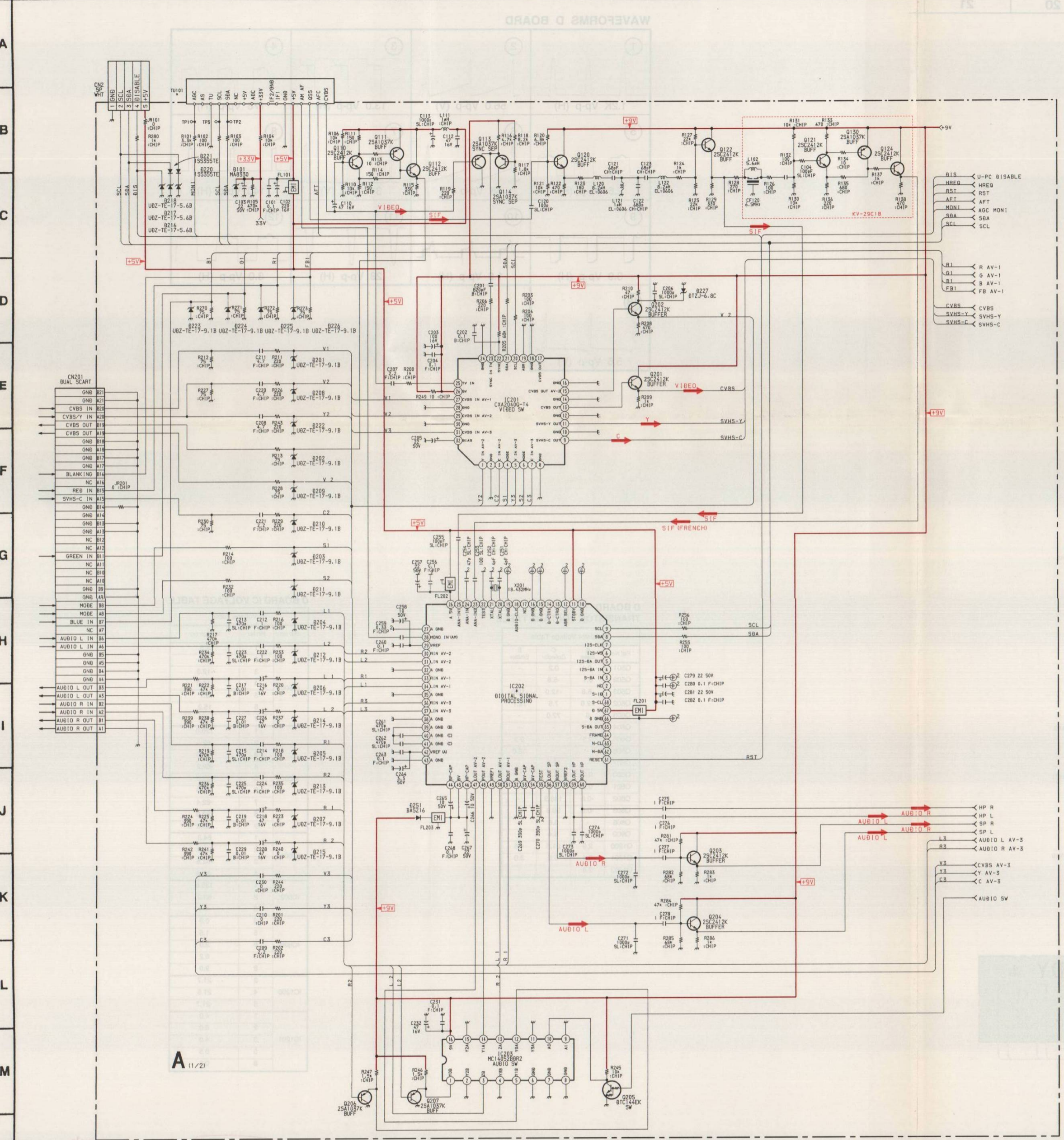

A (1/2) BOARD IC VOLTAGE TABLE

IC Voltage Table		
Ref No	Pin No	Voltage (V)
IC201	13	4.4
	15	4.4
	21	3.5
	22	4.5
	23	4.4
	24	0
	25	4.4
	26	8.8
	32	4.4
	4	2.8
	6-7	0.1
	8	3.0
IC202	9	3.6
	11	4.7
	13	4.7
	20-21	2.4
	23	0.2
	25	1.5
	26	4.8
	28	3.8
	29	2.6
	39-42	3.8
	44	7.1
	45	8.0
46	7.1	
47-48	3.8	
53-54	3.8	

A (2/2) BOARD TRANSISTOR VOLTAGE TABLE

Transistor Voltage Table				
Ref No	B	C	E	Emitter
Q1	3.7	4.8	3.1	-
Q4	0.1	4.8	-	-
Q5	0.7	4.8	4.0	-
Q15	-	4.3	-	-
Q16	4.3	0.2	-	-
Q17	0.4	3.5	-	-
Q18	3.5	0.7	-	-
Q80	2.6	2.2	-	-
Q81	2.4	-	3.0	-
Q304	-	4.8	-	-
Q305	-	4.8	-	-
Q330	4.5	-	5.1	-
Q331	6.3	8.8	5.7	-
Q332	3.1	8.8	2.5	-
Q1001	4.4	-	-	-

A (1/2) BOARD TRANSISTOR VOLTAGE TABLE

Transistor Voltage Table				
Ref No	B	C	E	Emitter
Q10	1.8	8.2	1.2	-
Q12	1.5	8.8	0.8	-
Q13	1.8	-	-	-
Q14	5.4	6.0	-	-
Q120	84.3	8.8	3.7	-
Q121	1.5	5.4	0.9	-
Q122	5.4	8.8	4.7	-
Q124	-	8.8	-	-
Q201	4.4	8.8	3.7	-
Q202	4.4	8.8	3.7	-

A BOARD * MARK

Ref. No.	29C1A	29C1B	29C1D	29C1D 1	29C1E	29C1K	29C1R
C19	-	-	-	-	-	0.033MF	0.033MF
C370	2.2UF	2.2UF	2.2UF	2.2UF	2.2UF	2.2UF	2.2UF
C372	0.1UF	0.1UF	0.1UF	0.1UF	0.1UF	0.1UF	0.1UF
C373	0.22UF	0.22UF	0.22UF	0.22UF	0.22UF	0.22UF	0.22UF
D370	BAS216	BAS216	BAS216	BAS216	BAS216	BAS216	BAS216
IC202	MSP3400C-PS	MSP3410-15	MSP3400C-PS	MSP3400C-PS	MSP3410-15	MSP3400C-PS	MSP3400C-PS
IC303	-	TDA8395T	TDA8395T	TDA8395T	TDA8395T	TDA8395T	TDA8395T
R81	-	-	-	-	4.7K	4.7K	-
TU101	TUVIF (AEP)	TUVIF (FR)	TUVIF (AEP)	TUVIF (AEP)	TUVIF (AEP)	TUVIF (AEP)	TUVIF (AEP)

Free service manuals
Gratis schemas
Digitized by
www.freecircuitsmanuals.info

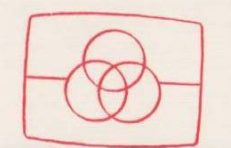

Free service manuals
Gratis schema's
Digitized by

www.freeremotemanuals.info

WAVEFORMS A BOARD

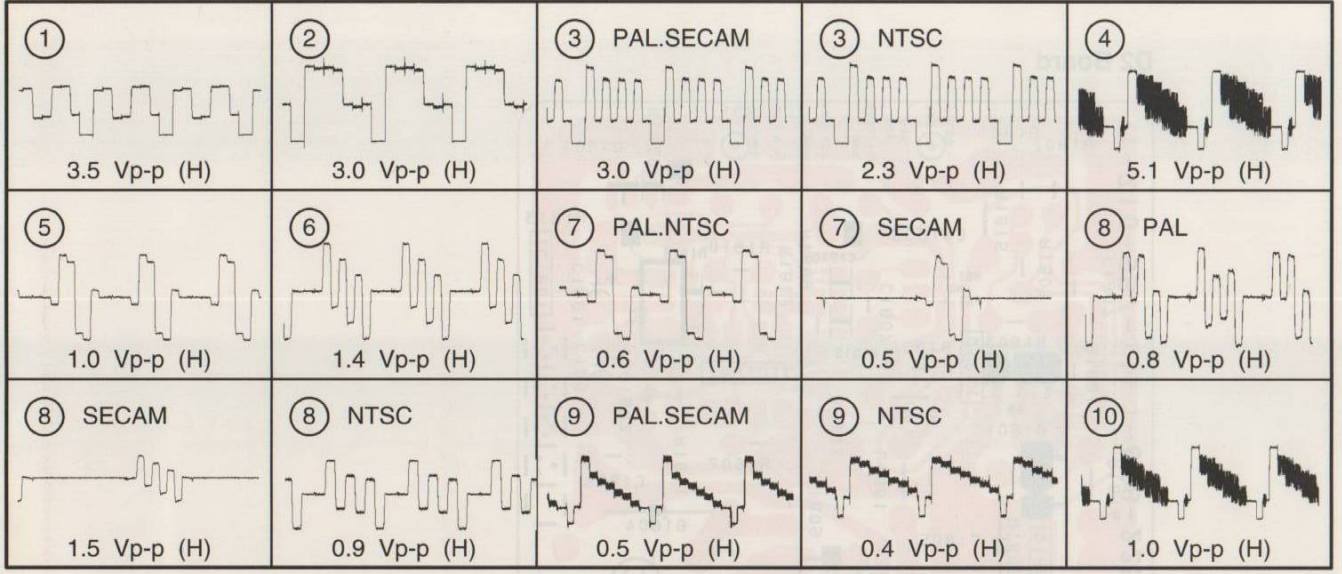

A TUNER, AUDIO CONTROL VIDEO SW, DIGITAL SIGNAL PROCESSING
Y/C JUNGLE MICRO CONTROLLER

A Board <Conductor Side>

A Board <Component Side>

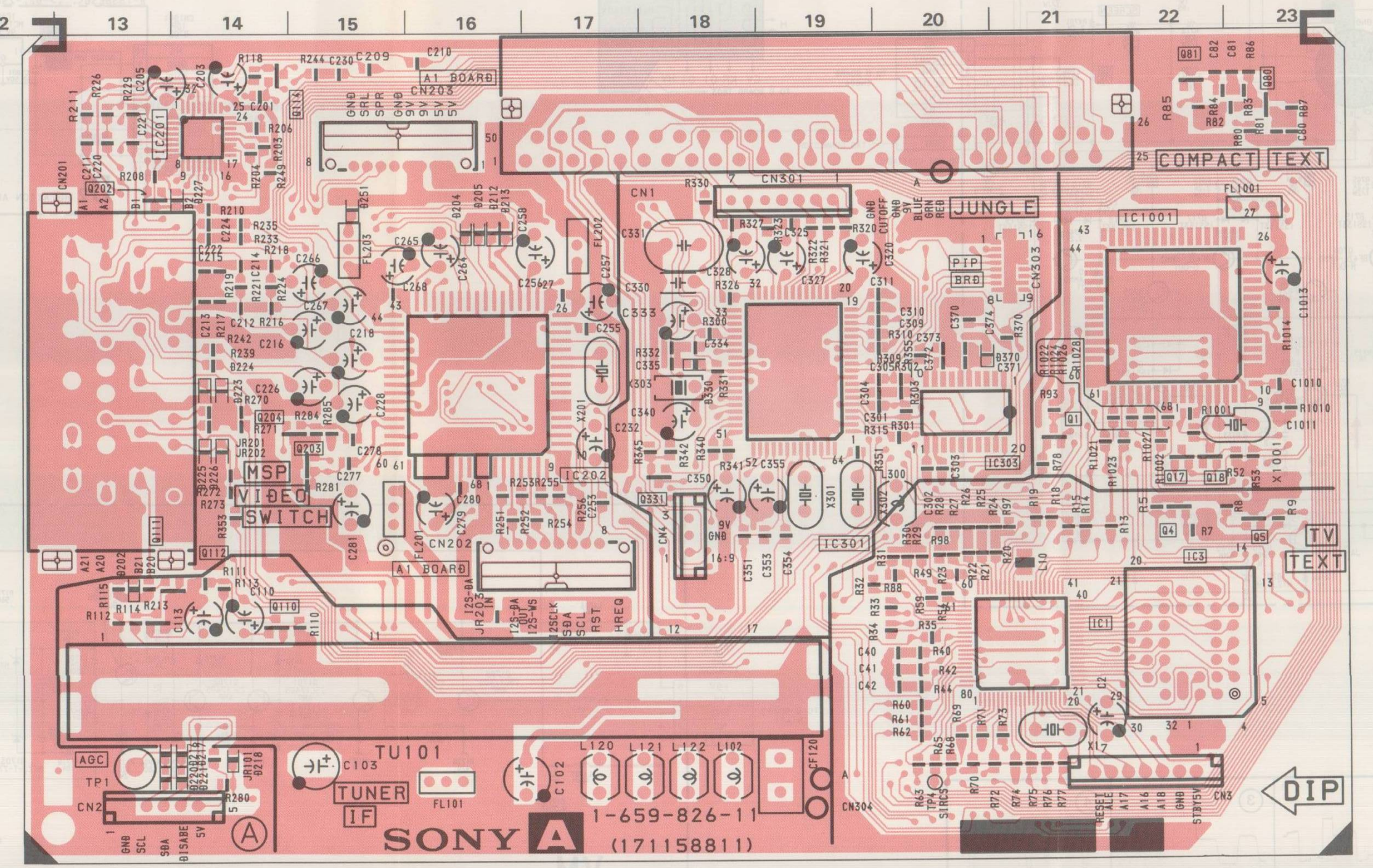
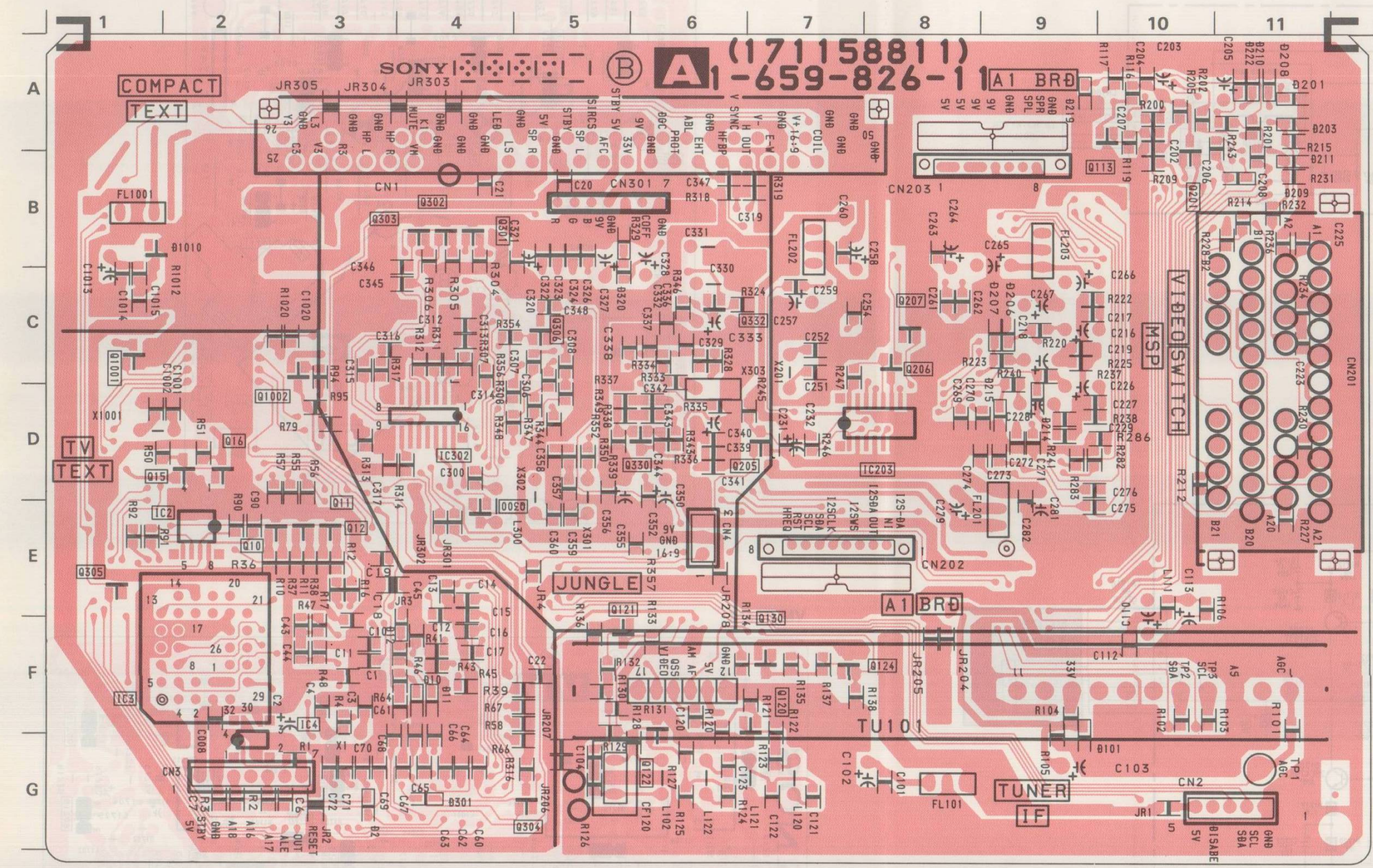

A (2/2) BOARD IC VOLTAGE TABLE

IC Voltage Table with columns for IC, Ref No, Pin No, and Voltage (V). Includes data for IC1, IC301, IC302, IC303, and IC1001.

A BOARD

IC and Component list table with columns for IC, Q305, and E-1. Lists various components like IC1, IC2, IC3, IC201, IC202, IC203, IC301, IC302, IC303, Q1, Q4, Q5, Q10, Q11, Q15, Q16, Q17, Q18, Q80, Q81, Q110, Q111, Q112, Q113, Q114, Q120, Q121, Q122, Q124, Q130, Q201, Q202, Q203, Q204, Q205, Q206, Q207, Q304.

KV-29C1

KV-29C1

KV-29C1

KV-29C1

KV-29C1

D2

[ROTATION AMP]

C [R, G, B OUT]

VM [VM AMP]

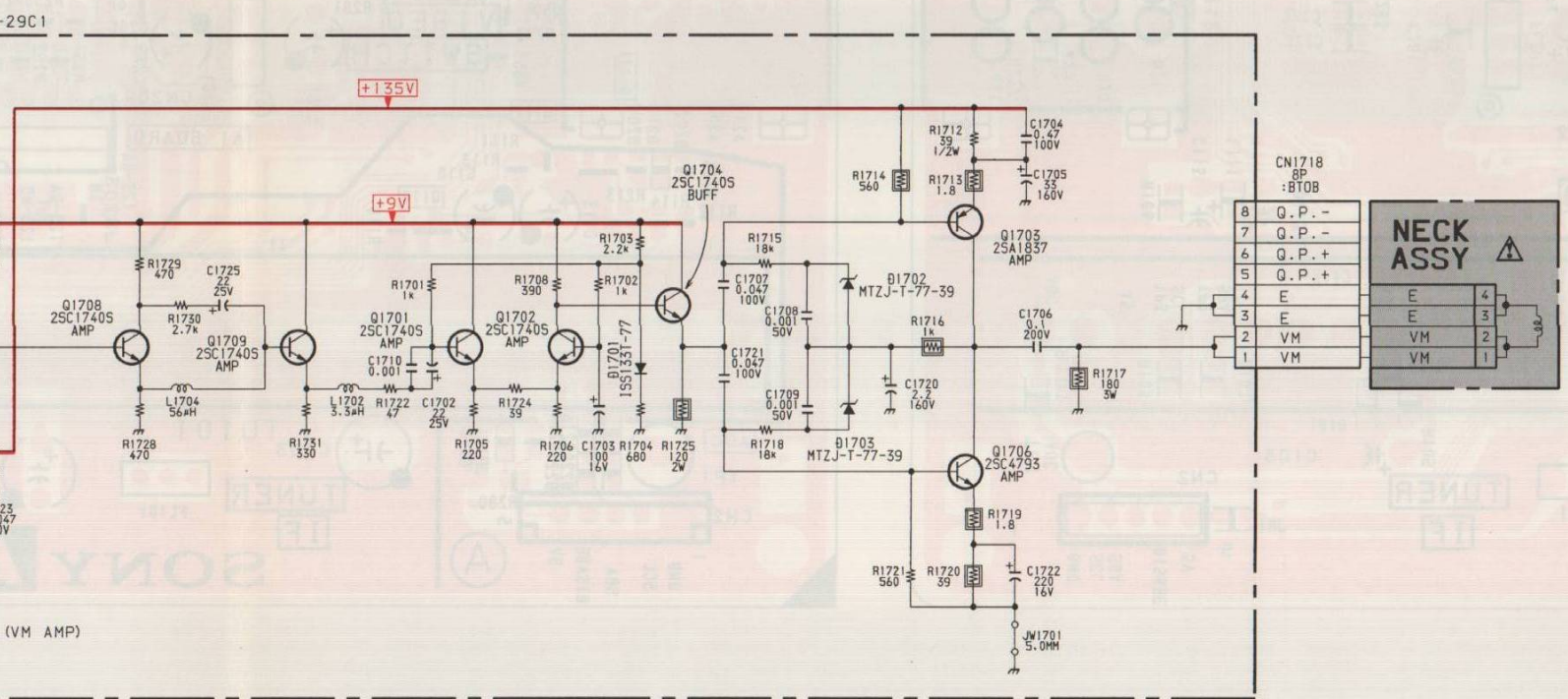
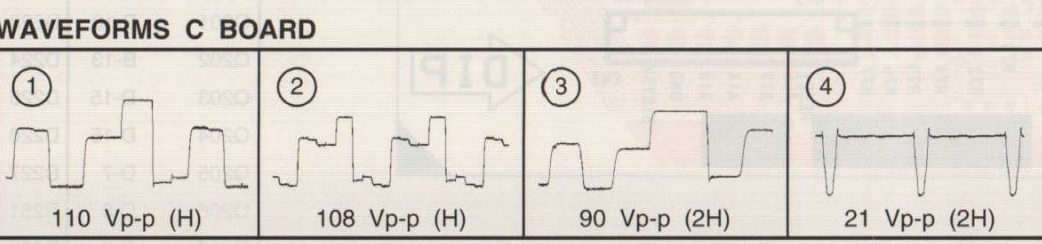
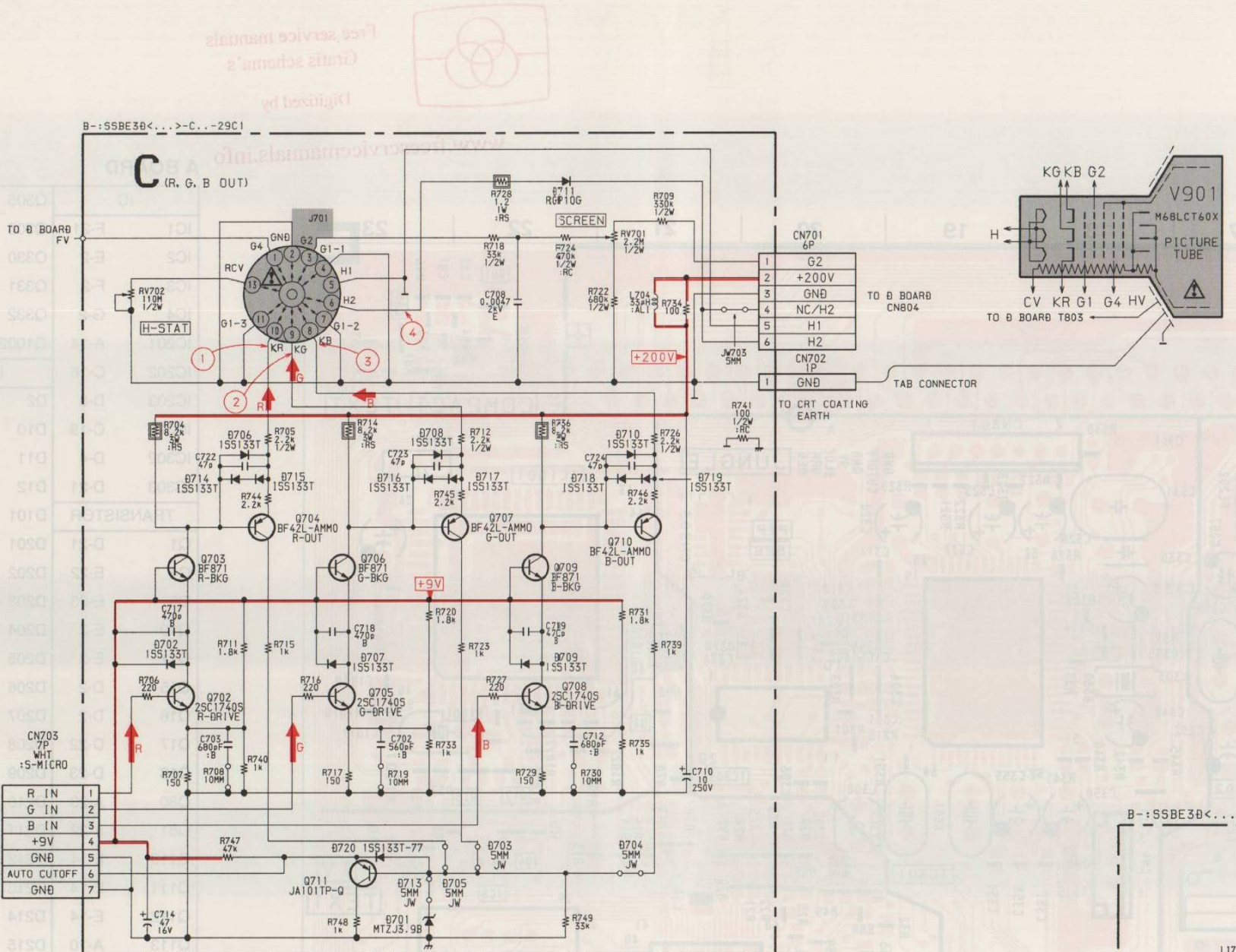

VM (VM AMP)

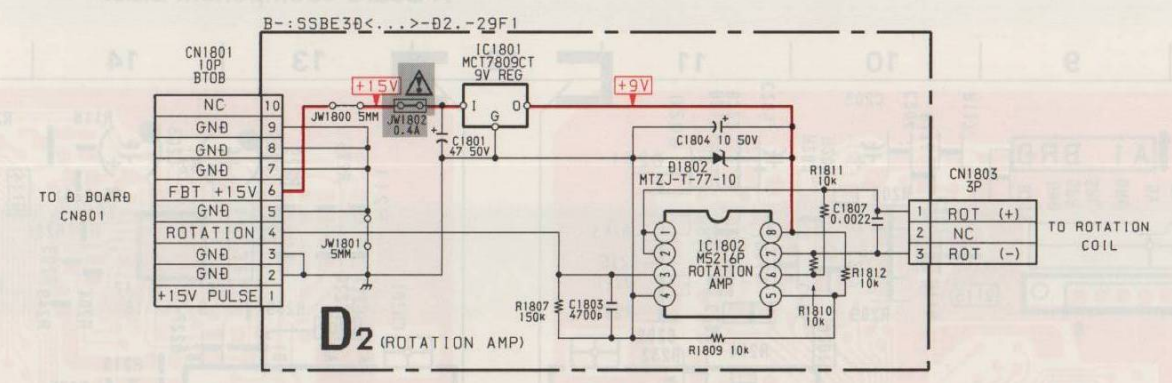

D2 (ROTATION AMP)

C Board

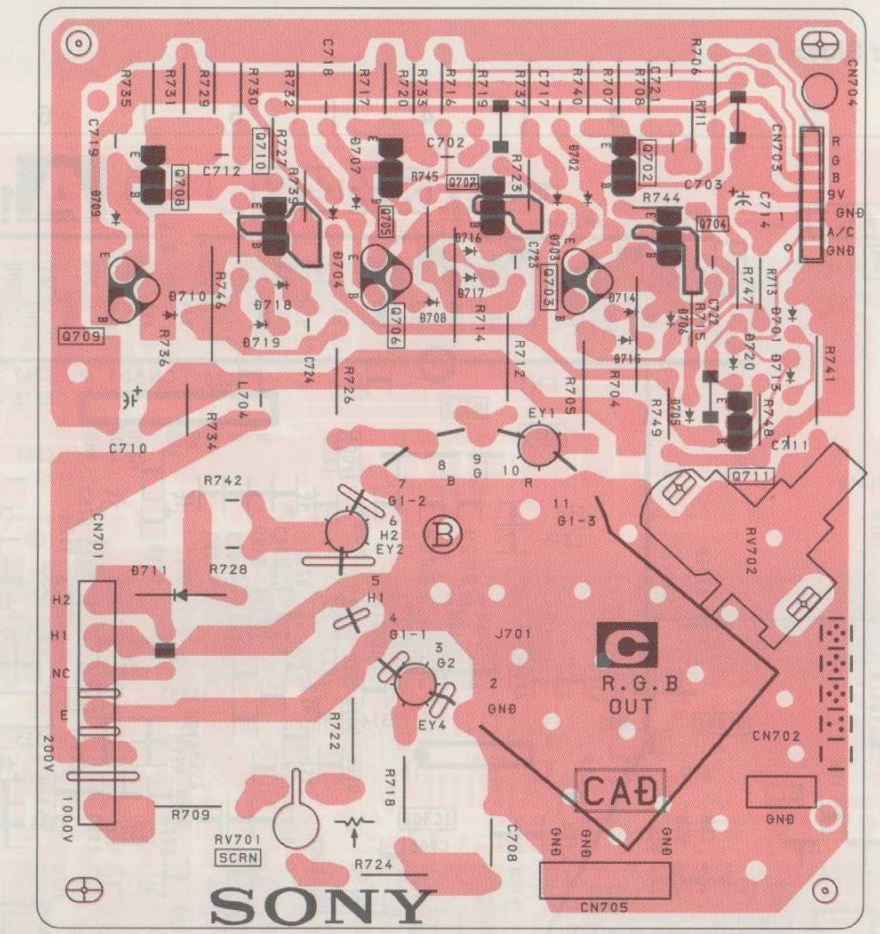

VM Board

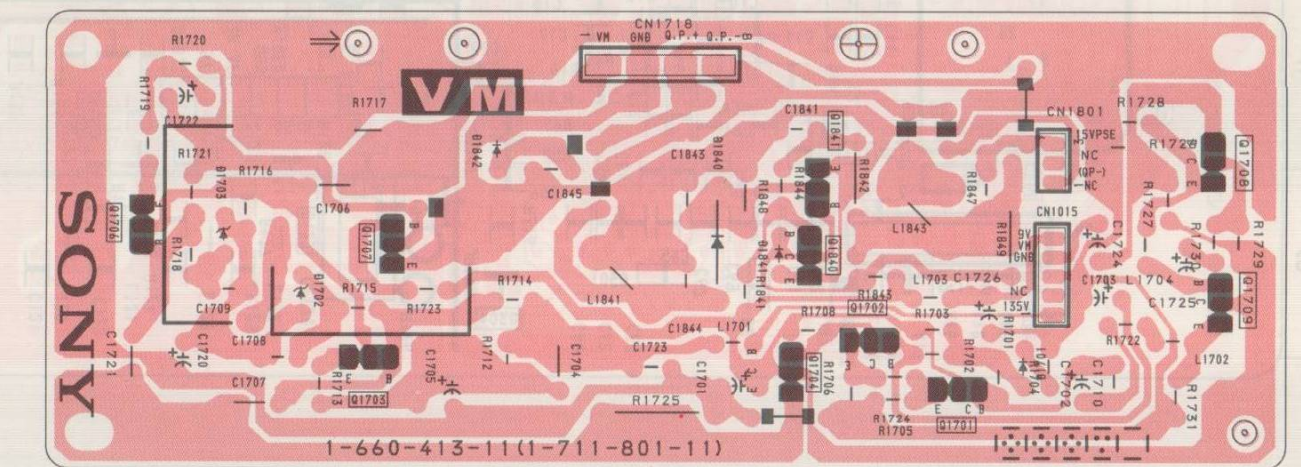

D2 Board

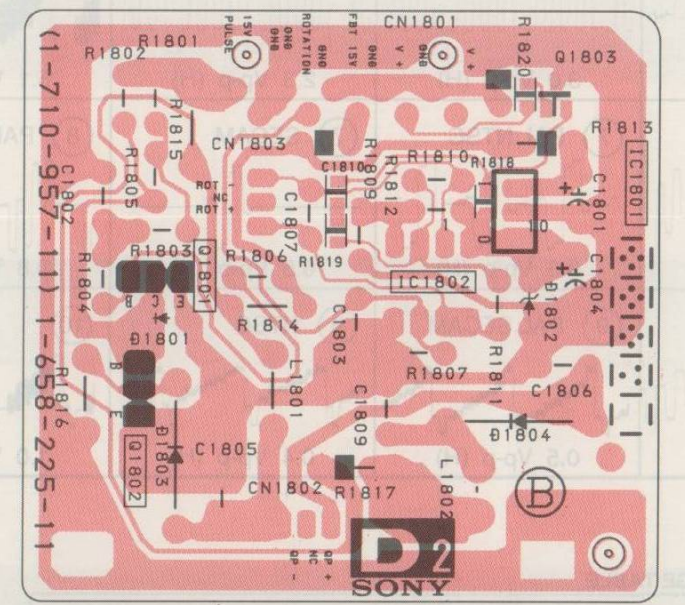

C BOARD TRANSISTOR VOLTAGE TABLE

Ref No	B	C	E
Q702	2.0	11.4	1.4
Q703	12.0	168.3	11.4
Q704	168.3	6.0	163.5
Q705	1.7	11.4	1.2
Q706	12.0	178.8	11.4
Q707	178.2	6.2	173.8
Q708	2.0	11.4	1.4
Q709	12.0	168.3	11.4
Q710	168.0	6.4	160.0

VM BOARD TRANSISTOR VOLTAGE TABLE

Ref No	B	C	E
Q1701	2.5	8.8	1.8
Q1702	2.5	5.5	1.8
Q1703	134.3	71.8	134.8
Q1704	5.5	8.8	4.8
Q1706	1.0	71.8	0.4
Q1707	0.7	-	-
Q1708	2.9	6.6	2.2
Q1709	2.2	8.8	1.5
Q1840	0.6	-	-

D2 BOARD IC VOLTAGE TABLE

Ref No	Pin No	Voltage (V)
IC1802	1-2	2.8
	3	3.0
	5-6	4.4
	7	6.2
	8	9.0
	9	9.0
	10	9.0
	11	9.0

VIF (AEP) (KV-29C1A, 29C1D, 29C1D 1, 29C1E, 29C1K ONLY)

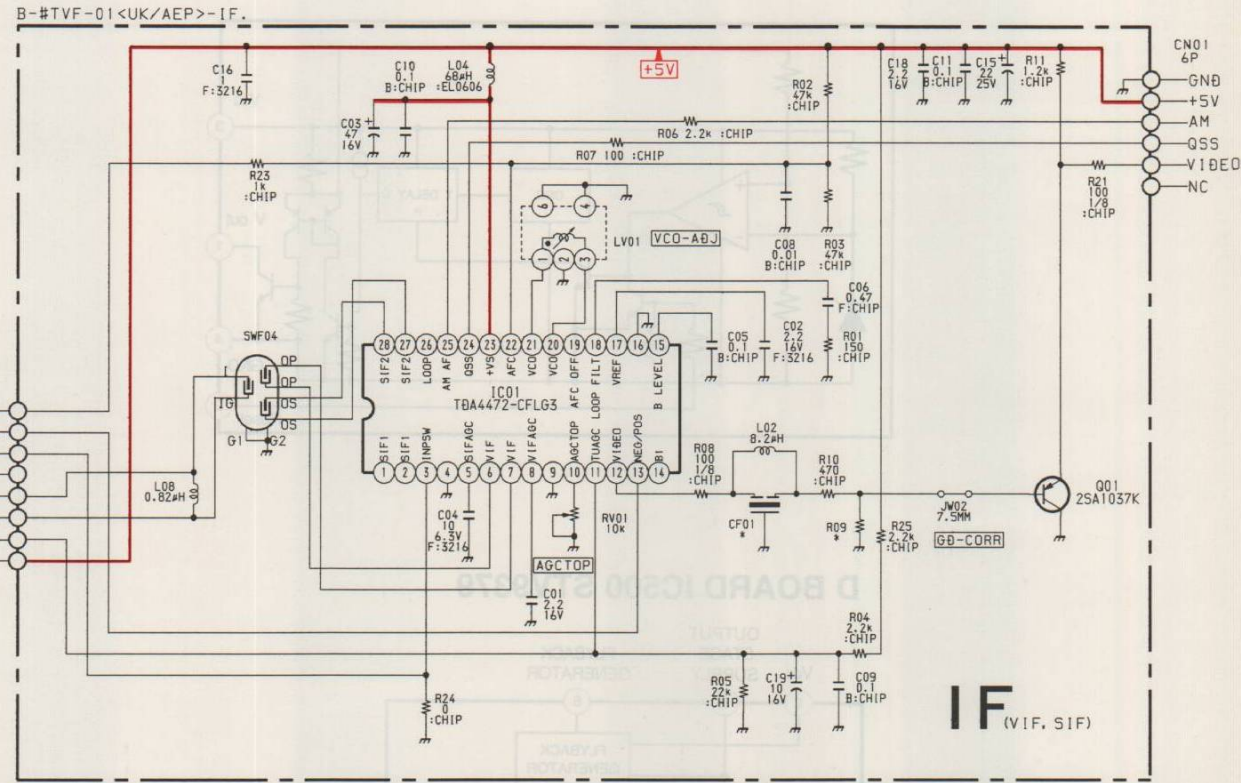

IF [VIF, SIF]

IF Board

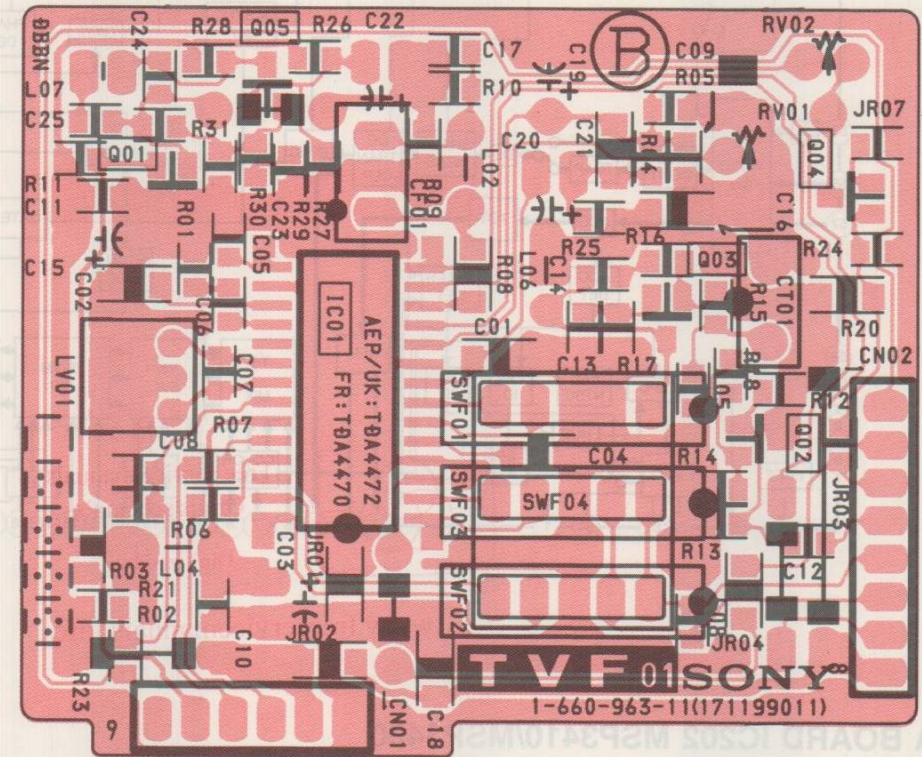

VIF (FR) (KV-29C1B ONLY)

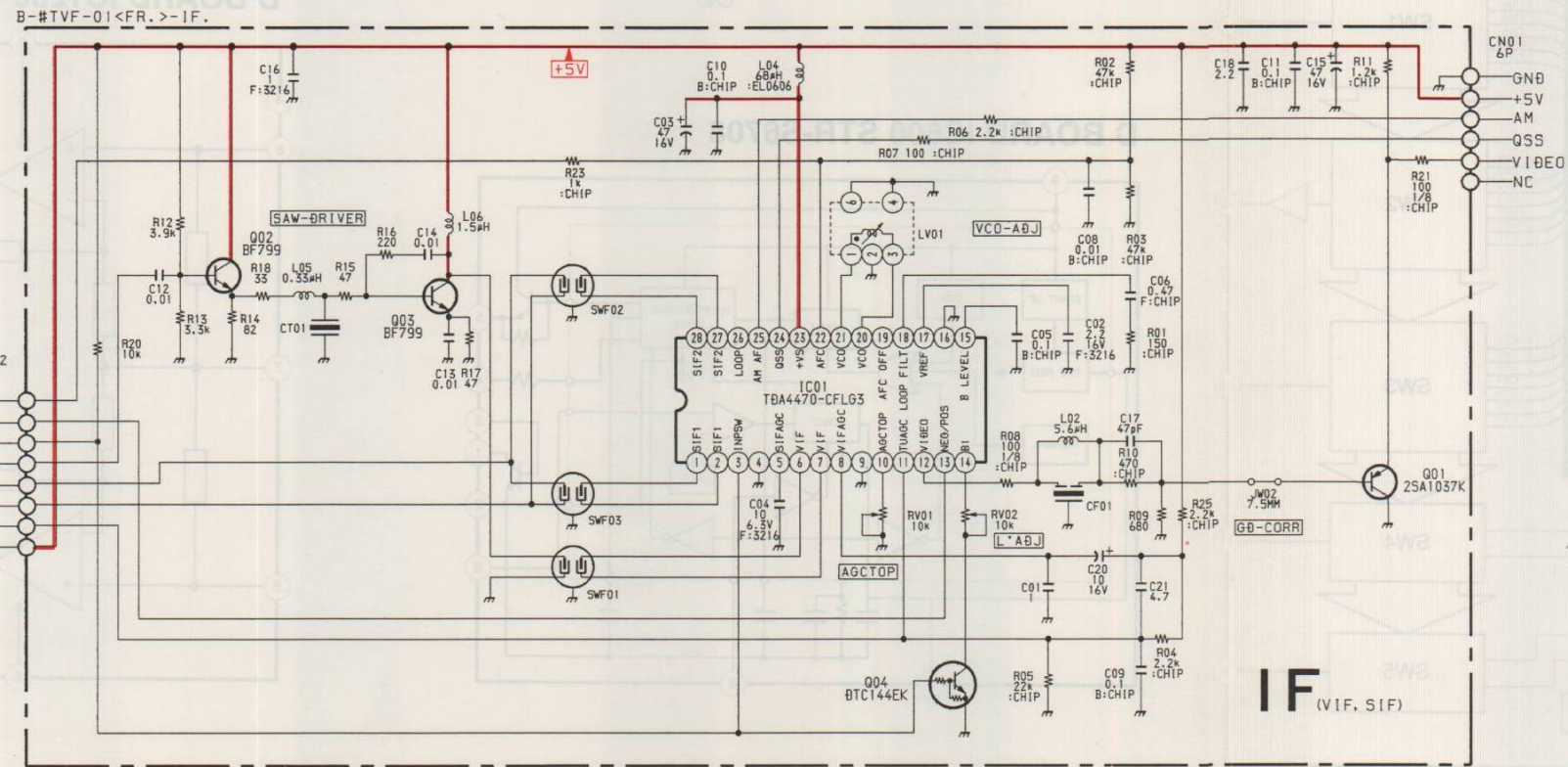

A BOARD IC301 CXA2000Q-TL

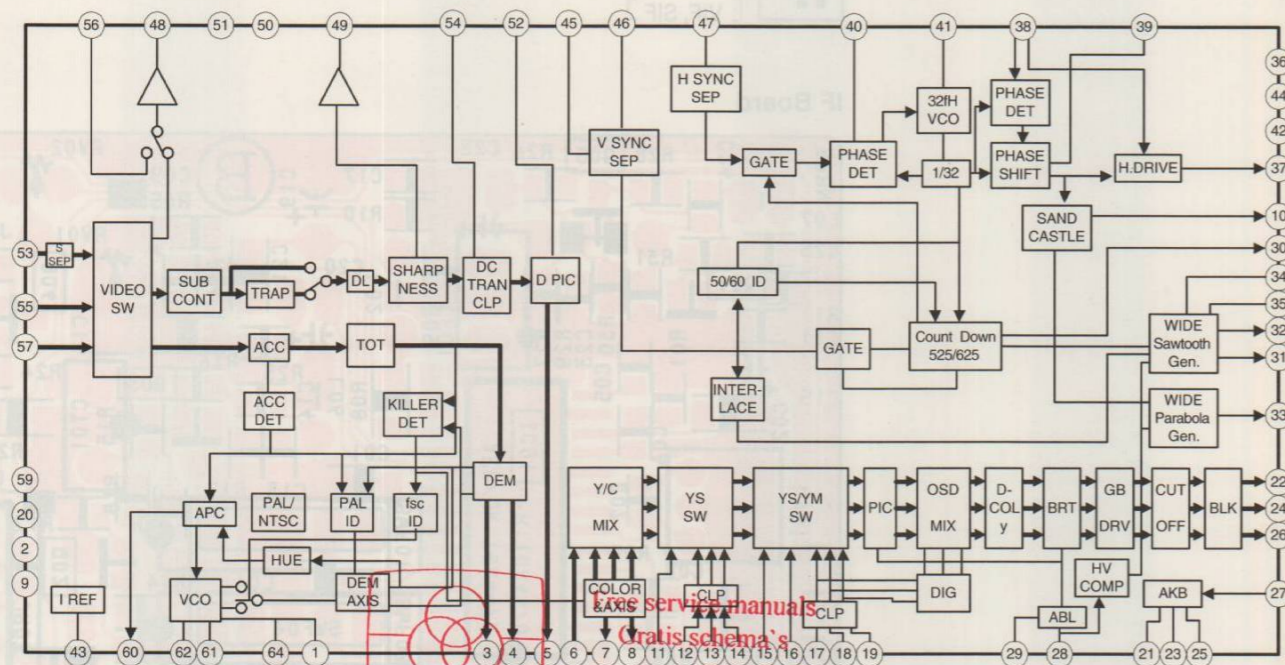

Digitized by

www.freeservicemanuals.info

A BOARD IC4 PST593C

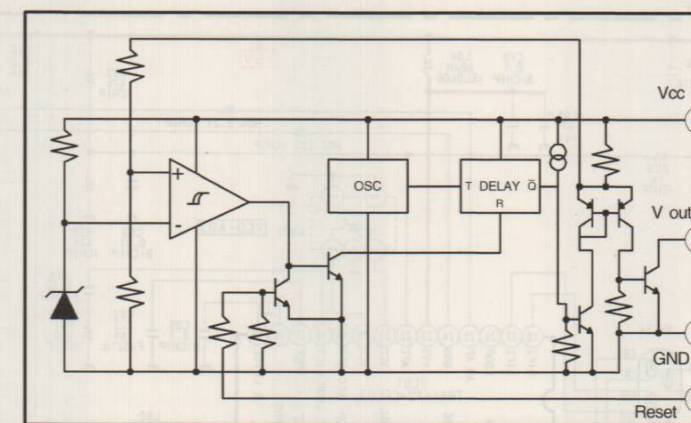

D BOARD IC500 STV9379

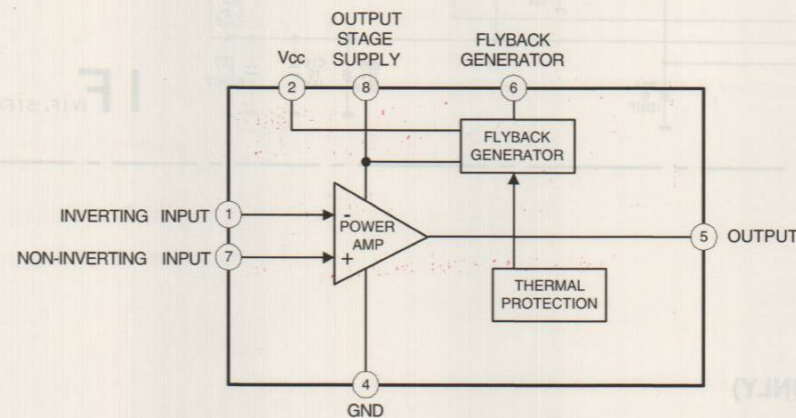

D BOARD IC1200 TDA7264

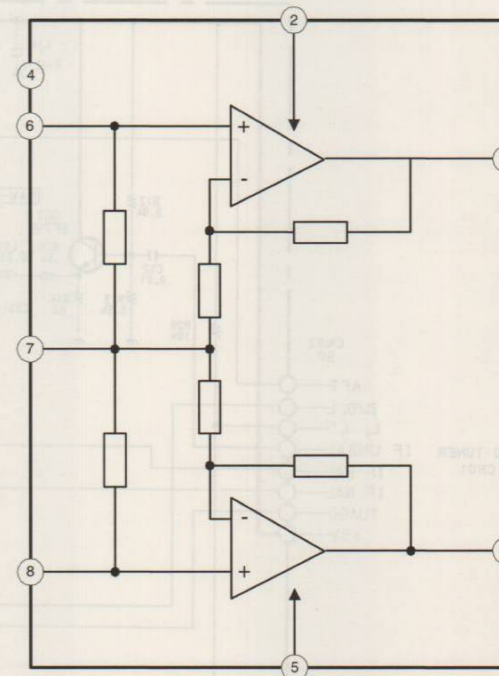

D BOARD IC600 STR-S6708

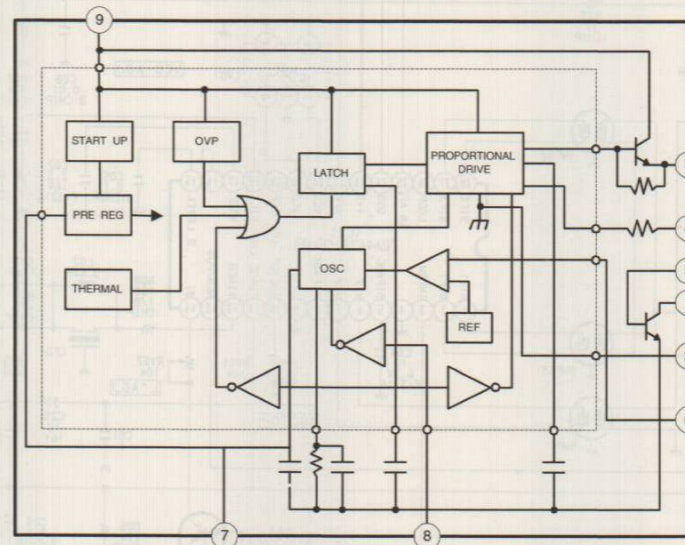

A BOARD IC201 CXA2040Q

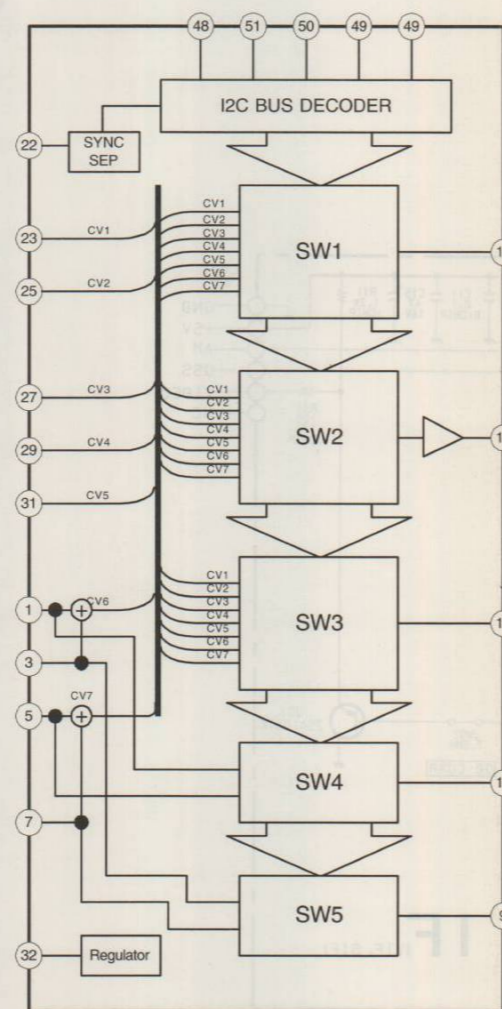

A BOARD IC202 MSP3410/MSP3400

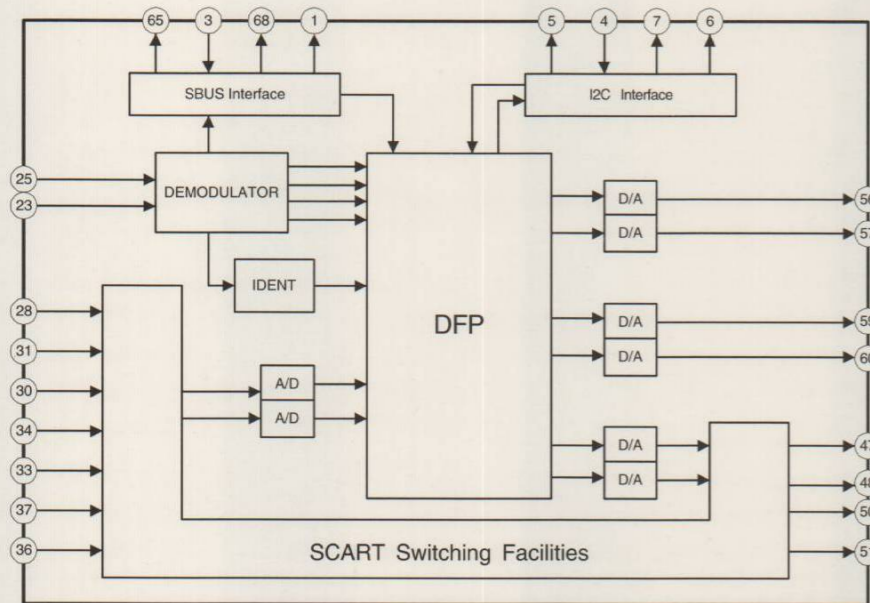

5-4. SEMICONDUCTORS

CXA2000Q-TL

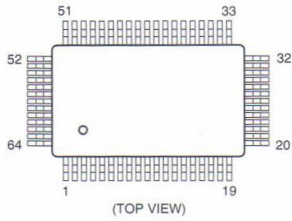

MC14052BDR2

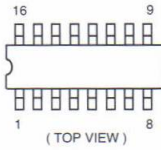

ST24E32M6TR

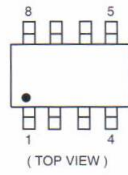

TMS27PC010A-15FML

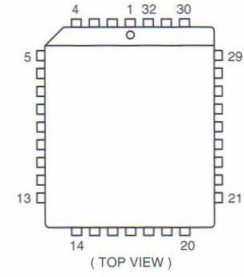

MSP3400C-PS
MSP3410-15

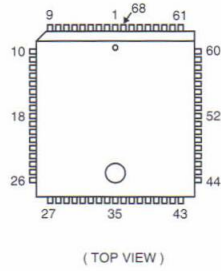

STR-S6708

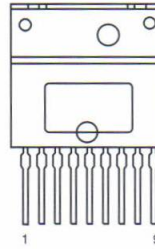

CXA2040Q-T4

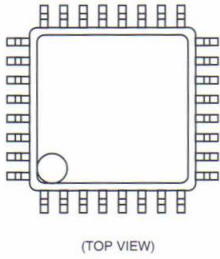

BF871-127

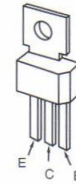

L4941BV

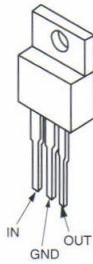

PST593C-MMP-4P

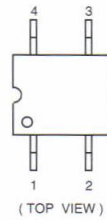

STV9379

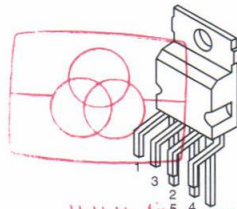

- BF421L-AMMO
- JA101TP-Q
- 2SA733-K
- 2SA933AS
- 2SA933S
- 2SA1091-O
- 2SC3502-F
- 2SC2808STP-R

Free service manuals
Gratis schemas
Digitized by
www.freeremotemanuals.info



- LM393P
- M5216P
- TDA2822M
- µPC393C

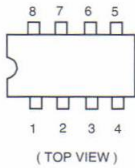

SBX1790-51



TDA4665T-T

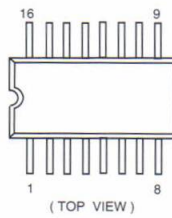

- DTA144ES
- DTC114ES
- DTC143TS
- DTC144ES
- 2SC1740S-RT

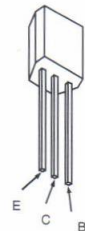

- LM2940CT-5.0
- LM2940T-9.0
- MCT7809CT
- NJM78M09FA
- µPC2405HF

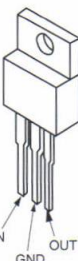

SDA5250M-GEG

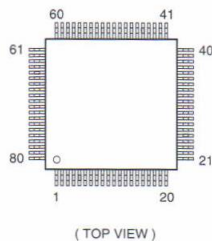

TDA7264

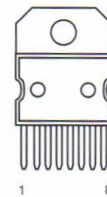

SE135N

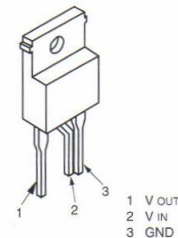

TDA8395T

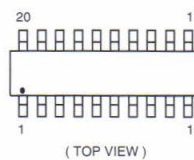

- DTC144EK
- 2SA1037K
- 2SA1162-G
- 2SC2412K

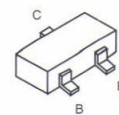

TLP721(D4-)



- AU-01Z-V1 GP08D
- EG-1Z-V1 RGP02
- EGP20G RGP10GPKG23
- EL1Z RGP15GPKG23
- EM1-V1 RU3YX
- EU-1-V1 RU4AM-T3
- EU2-V1 RU4DS
- FML-G12S

- MTZJ-3.6A RD3.9ESB2
- MTZJ-3.9B RD5.1ESB2
- MTZJ-5.1B RD5.6ESB2
- MTZJ-5.6B RD6.2ESB2
- MTZJ-6.2B RD6.8ESB2
- MTZJ-6.8B RD7.5ESB2
- MTZJ-7.5C RD10ESB2
- MTZJ-T-77-9.1A
- MTZJ-10 RD39ES-B2
- MTZJ-39C 1SS133T-77

2SA1175-HFE
2SC2785-HFE

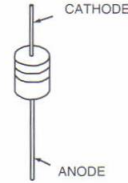
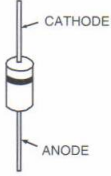
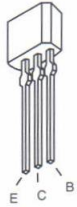

- BAS216 MA8330
- DTZ6.8C 1SS355
- DTZ9.1 UDZ-TE-17-5.6B
- DTZ33B UDZ-TE-17-9.1B

2SA1667
2SA1837
2SC3852A

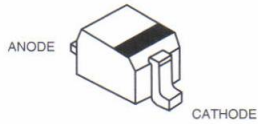
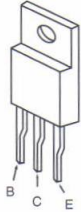

SLA-570KT3F

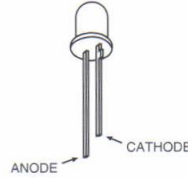

2SC2688-LK

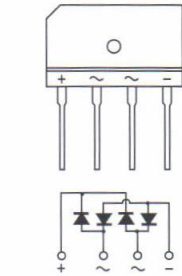
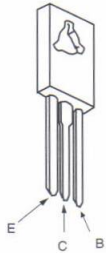

FMS-3FU

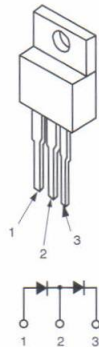

2SC4793



2SC4927-01

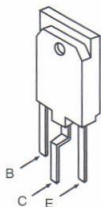

MA3030H(TX)

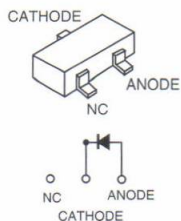

SECTION 6

EXPLODED VIEWS

NOTE :

- Items with no part number and no description are not stocked because they are seldom required for routine service.
- The construction parts of an assembled part are indicated with a collation number in the remarks column.
- Items marked " * " are not stocked since they are seldom required for routine service. Some delay should be anticipated when ordering these items.





The components identified by shading and marked  are critical for safety.

Replace only with the part number specified.

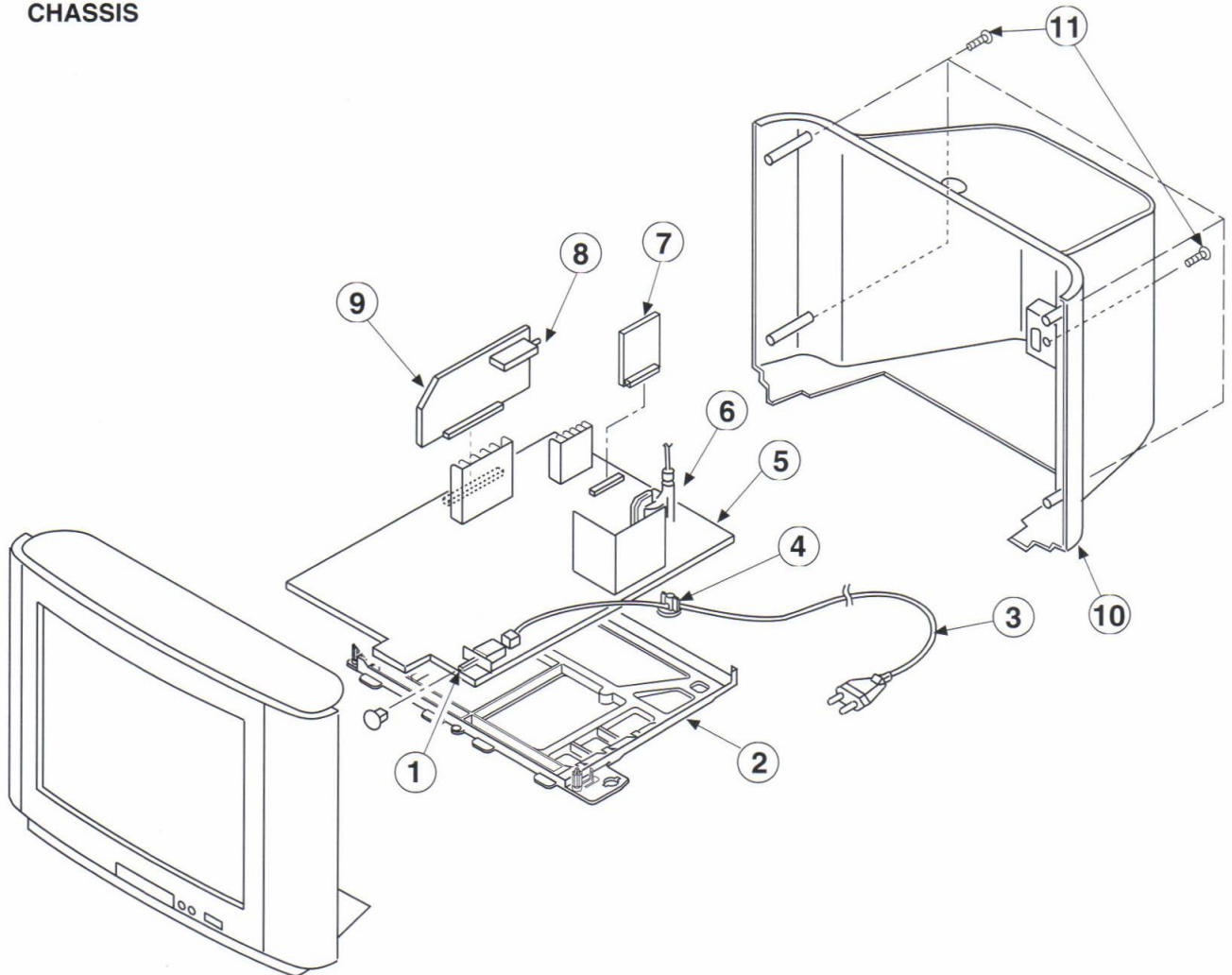
Les composants identifiés par une trame et une marque  sont critiques pour la sécurité.

Ne les remplacer que par une pièce portant le numéro spécifié.

6-1. CHASSIS



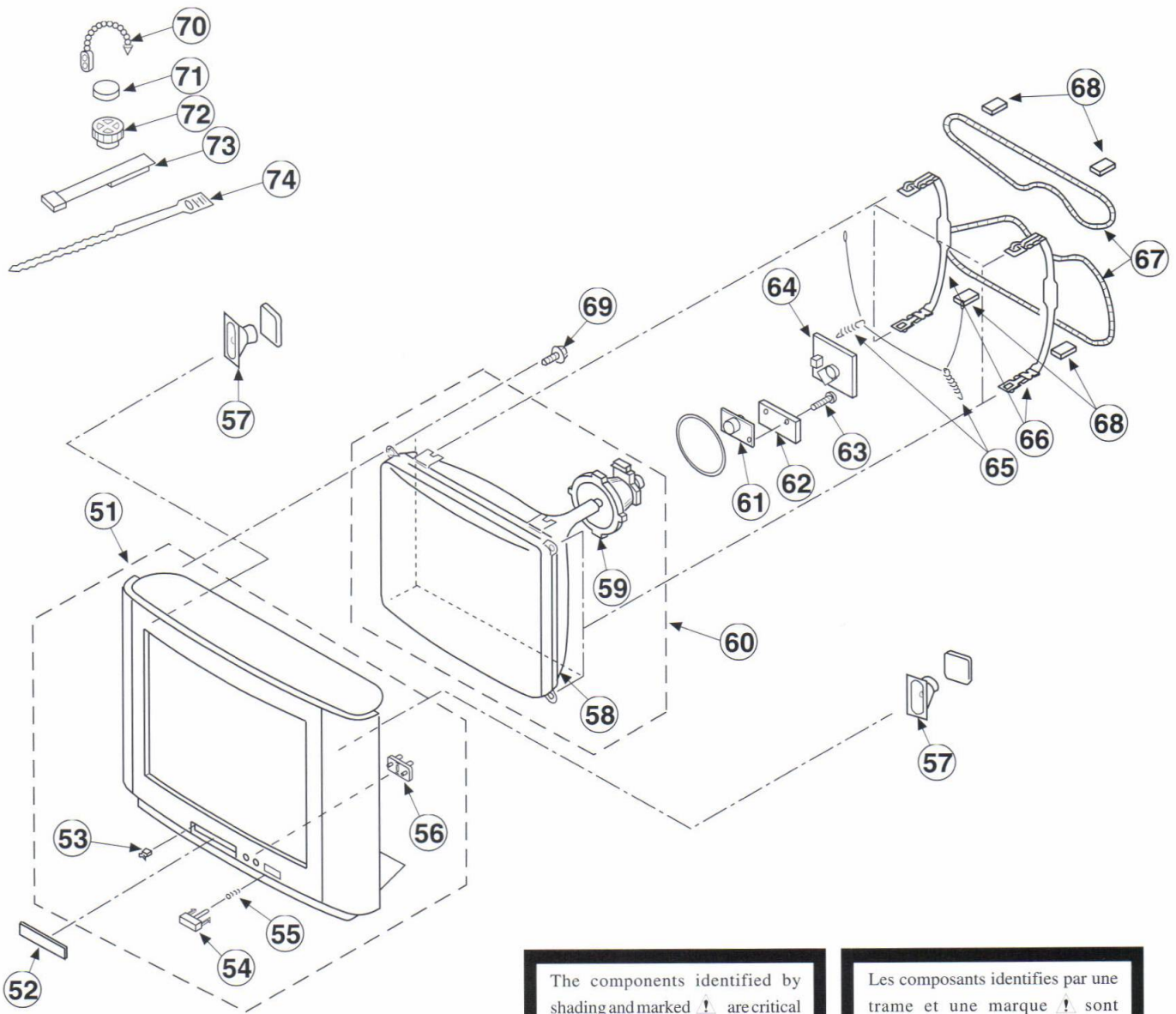

REF NO	PART NO	DESCRIPTION	REMARK	REF NO	PART NO	DESCRIPTION	REMARK
1	 1-571-433-21	SWITCH, PUSH (AC POWER)		8	1-693-338-11	TUNER/VIF (AEP) (KV-29C1A/29C1D/29C1E/29C1K/ 29C1R)	
2	*4-202-998-11	BRACKET, MAIN		9	1-693-340-11	TUNER/VIF (FR) (KV-29C1B)	
3	 1-751-680-11	CORD, POWER (WITH NOISE FILTER) 2.5A/250V (KV-29C1A/29C1D/29C1E/29C1K/29C1R)			*A-1632-423-A	A BOARD, COMPLETE (KV-29C1A)	
4	 1-690-270-21	CORD, POWER (WITH CONNECTOR) 2.5A/250V (KV-29C1B/29C1E/29C1K/29C1R)			*A-1632-425-A	A BOARD, COMPLETE (KV-29C1B)	
5	*4-202-531-01	AC CORD LOCK (SC)			*A-1632-422-A	A BOARD, COMPLETE (KV-29C1D/29C1E/29C1K/29C1R)	
6	*A-1642-165-A	D BOARD, COMPLETE (KV-29C1A/29C1B/29C1D/29C1E/29C1K/ 29C1R)			*A-1632-424-A	A BOARD, COMPLETE (KV-29C1E)	
7	*A-1642-188-A	D BOARD, COMPLETE (KV-29C1D 1)			*A-1632-426-A	A BOARD, COMPLETE (KV-29C1K)	
8	 1-453-169-11	TRANSFORMER ASSY, FLYBACK (UX-1604A2)		10	4-202-993-01	COVER, REAR	
9	*A-1640-214-A	D2 BOARD, COMPLETE		11	4-039-358-01	SCREW (4x16), (+) BV TAPPING	

6-2. PICTURE TUBE



The components identified by shading and marked  are critical for safety. Replace only with the part number specified.

Les composants identifiés par une trame et une marque  sont critiques pour la sécurité. Ne les remplacer que par une pièce portant le numéro spécifié.

REF NO	PART NO	DESCRIPTION	REMARK	REF NO	PART NO	DESCRIPTION	REMARK
51	X-4200-253-1	BEZNET ASSY	53-56	64	*A-1638-082-A	C BOARD, COMPLETE	
52	4-203-340-01	DOOR		65	4-369-318-31	SPRING, TENSION	
53	4-392-036-01	CATCHER, PUSH (KV-29C1A/29C1B/29C1D/29C1E/29C1K/ 29C1R)		66	4-202-415-01	CLIP, DGC (29")	
	4-047-464-01	CATCHER, PUSH (KV-29C1D 1)		67	 1-406-807-11	COIL, DEGAUSSING	
54	4-203-339-01	BUTTON, POWER		68	*4-203-390-01	CUSHION, DGC	
55	4-202-964-01	SPRING		69	4-036-188-01	SCREW (M), PT	
56	*4-203-338-11	GUIDE, LIGHT		70	4-308-870-00	CLIP, LEAD WIRE	
57	1-504-146-11	SPEAKER (5x11CM)		71	1-452-032-00	MAGNET, DISK; 10MM Ø	
58	 8-733-856-05	PICTURE TUBE (SD-269) (M68LCT60X)		72	1-452-094-00	MAGNET, ROTATABLE DISK; 15MM Ø	
59	 8-451-467-11	DEFLECTION YOKE (Y29GXA2B)		73	X-4387-214-1	PERMALLOY ASSY, CORRECTION	
60	 8-733-856-71	ITC	58 -59	74	3-701-007-00	BAND, BINDING	
61	 8-453-005-11	NECK ASSY (NA297-M)					
62	*A-1644-070-A	VM BOARD, COMPLETE					
63	4-639-357-01	SCREW(3x8), (+) BV TAPPING					

A

REF.NO.	PART NO.	DESCRIPTION	REMARK	REF.NO.	PART NO.	DESCRIPTION	REMARK
C259	1-164-336-11	CERAMIC CHIP 0.33MF	25V	C340	1-126-933-11	ELECT 100MF	20% 16V
C260	1-163-038-00	CERAMIC CHIP 0.1MF	25V	C341	1-164-005-11	CERAMIC CHIP 0.47MF	25V
C261	1-163-133-00	CERAMIC CHIP 470PF	5% 50V	C342	1-164-346-11	CERAMIC CHIP 1MF	16V
C262	1-163-133-00	CERAMIC CHIP 470PF	5% 50V	C343	1-163-017-00	CERAMIC CHIP 0.0047MF	10% 50V
C263	1-163-038-00	CERAMIC CHIP 0.1MF	25V	C344	1-163-117-00	CERAMIC CHIP 100PF	5% 50V
C264	1-126-962-11	ELECT 3.3MF	20% 50V	C347	1-164-005-11	CERAMIC CHIP 0.47MF	25V
C265	1-126-964-11	ELECT 10MF	20% 50V	C348	1-163-038-00	CERAMIC CHIP 0.1MF	25V
C266	1-126-964-11	ELECT 10MF	20% 50V	C350	1-126-964-11	ELECT 10MF	20% 50V
C267	1-126-965-11	ELECT 22MF	20% 50V	C351	1-164-505-11	CERAMIC CHIP 2.2MF	16V
C268	1-163-038-00	CERAMIC CHIP 0.1MF	25V	C352	1-164-005-11	CERAMIC CHIP 0.47MF	25V
C269	1-163-131-00	CERAMIC CHIP 390PF	5% 50V	C353	1-164-505-11	CERAMIC CHIP 2.2MF	16V
C270	1-163-131-00	CERAMIC CHIP 390PF	5% 50V	C354	1-164-005-11	CERAMIC CHIP 0.47MF	25V
C271	1-163-141-00	CERAMIC CHIP 0.001MF	5% 50V	C355	1-126-965-11	ELECT 22MF	20% 50V
C272	1-163-141-00	CERAMIC CHIP 0.001MF	5% 50V	C356	1-164-232-11	CERAMIC CHIP 0.01MF	10% 50V
C273	1-163-141-00	CERAMIC CHIP 0.001MF	5% 50V	C357	1-163-133-00	CERAMIC CHIP 470PF	5% 50V
C274	1-163-141-00	CERAMIC CHIP 0.001MF	5% 50V	C358	1-164-005-11	CERAMIC CHIP 0.47MF	25V
C275	1-164-346-11	CERAMIC CHIP 1MF	16V	C359	1-163-231-11	CERAMIC CHIP 15PF	5% 50V
C276	1-164-346-11	CERAMIC CHIP 1MF	16V	C360	1-163-231-11	CERAMIC CHIP 15PF	5% 50V
C277	1-164-346-11	CERAMIC CHIP 1MF	16V	C370	1-164-505-11	CERAMIC CHIP 2.2MF	16V
C278	1-164-346-11	CERAMIC CHIP 1MF	16V			(KV-29C1B/29C1D/29C1E/29C1K/29C1R)	1/29C1E/29C1K/29C1R
C279	1-126-965-11	ELECT 22MF	20% 50V	C371	1-163-141-00	CERAMIC CHIP 0.001MF	5% 50V
C280	1-163-038-00	CERAMIC CHIP 0.1MF	25V	C372	1-164-004-11	CERAMIC CHIP 0.1MF	10% 25V
C281	1-126-965-11	ELECT 22MF	20% 50V			(KV-29C1B/29C1D/29C1E/29C1K/29C1R)	1/29C1E/29C1K/29C1R
C282	1-163-038-00	CERAMIC CHIP 0.1MF	25V	C373	1-164-489-11	CERAMIC CHIP 0.22MF	10% 16V
C301	1-163-038-00	CERAMIC CHIP 0.1MF	25V			(KV-29C1B/29C1D/29C1E/29C1K/29C1R)	1/29C1E/29C1K/29C1R
C302	1-163-141-00	CERAMIC CHIP 0.001MF	5% 50V	C1001	1-163-235-11	CERAMIC CHIP 22PF	5% 50V
C303	1-163-141-00	CERAMIC CHIP 0.001MF	5% 50V	C1002	1-163-235-11	CERAMIC CHIP 22PF	5% 50V
C304	1-163-038-00	CERAMIC CHIP 0.1MF	25V	C1010	1-163-038-00	CERAMIC CHIP 0.1MF	25V
C305	1-163-038-00	CERAMIC CHIP 0.1MF	25V	C1014	1-163-038-00	CERAMIC CHIP 0.1MF	25V
C306	1-164-232-11	CERAMIC CHIP 0.01MF	10% 50V	C1020	1-163-101-00	CERAMIC CHIP 22PF	5% 50V
C307	1-164-232-11	CERAMIC CHIP 0.01MF	10% 50V			< FILTER >	
C308	1-164-232-11	CERAMIC CHIP 0.01MF	10% 50V	CF120	1-409-327-00	TRAP, CERAMIC (6.5MHz)	(KV-29C1B)
C309	1-164-346-11	CERAMIC CHIP 1MF	16V			< CONNECTOR >	
C310	1-164-346-11	CERAMIC CHIP 1MF	16V	CN1	1-695-302-11	CONNECTOR, BOARD TO BOARD	50P
C311	1-164-346-11	CERAMIC CHIP 1MF	16V	CN2	*1-568-880-51	PLUG, CONNECTOR	5P
C312	1-164-505-11	CERAMIC CHIP 2.2MF	16V	CN201	1-766-296-11	CONNECTOR, DUAL SCART	
C313	1-163-141-00	CERAMIC CHIP 0.001MF	5% 50V	CN301	*1-568-882-51	PIN, CONNECTOR	7P
C315	1-216-295-00	METAL GLAZE 0	5% 1/10W			< DIODE >	
C317	1-163-038-00	CERAMIC CHIP 0.1MF	25V	D2	8-719-988-62	DIODE 1SS355	
C319	1-163-989-11	CERAMIC CHIP 0.033MF	10% 25V	D10	8-719-158-15	DIODE RD5.6S-B	
C320	1-126-965-11	ELECT 22MF	20% 50V	D11	8-719-158-15	DIODE RD5.6S-B	
C321	1-164-232-11	CERAMIC CHIP 0.01MF	10% 50V	D12	8-719-158-15	DIODE RD5.6S-B	
C322	1-164-004-11	CERAMIC CHIP 0.1MF	10% 25V	D101	8-719-977-81	DIODE DTZ33B	
C323	1-164-004-11	CERAMIC CHIP 0.1MF	10% 25V	D201	8-719-977-22	DIODE DTZ9.1	
C324	1-164-004-11	CERAMIC CHIP 0.1MF	10% 25V	D202	8-719-977-22	DIODE DTZ9.1	
C325	1-164-346-11	CERAMIC CHIP 1MF	16V	D203	8-719-977-22	DIODE DTZ9.1	
C326	1-163-141-00	CERAMIC CHIP 0.001MF	5% 50V	D204	8-719-977-22	DIODE DTZ9.1	
C327	1-137-374-11	FILM 0.047MF	5% 50V	D205	8-719-977-22	DIODE DTZ9.1	
C328	1-126-964-11	ELECT 10MF	20% 50V	D206	8-719-977-22	DIODE DTZ9.1	
C329	1-164-232-11	CERAMIC CHIP 0.01MF	10% 50V	D207	8-719-977-22	DIODE DTZ9.1	
C330	1-130-777-00	FILM 0.1MF	5% 63V	D208	8-719-977-22	DIODE DTZ9.1	
C331	1-137-581-11	FILM 0.1MF	5% 100V	D209	8-719-977-22	DIODE DTZ9.1	
C332	1-164-232-11	CERAMIC CHIP 0.01MF	10% 50V	D210	8-719-977-22	DIODE DTZ9.1	
C333	1-126-933-11	ELECT 100MF	20% 16V	D211	8-719-977-22	DIODE DTZ9.1	
C334	1-164-232-11	CERAMIC CHIP 0.01MF	10% 50V				
C335	1-164-004-11	CERAMIC CHIP 0.1MF	10% 25V				
C336	1-163-017-00	CERAMIC CHIP 0.0047MF	10% 50V				
C337	1-164-232-11	CERAMIC CHIP 0.01MF	10% 50V				
C338	1-164-346-11	CERAMIC CHIP 1MF	16V				
C339	1-164-232-11	CERAMIC CHIP 0.01MF	10% 50V				



REF.NO.	PART NO.	DESCRIPTION	REMARK	REF.NO.	PART NO.	DESCRIPTION	REMARK
D212	8-719-977-22	DIODE DTZ9.1		Q18	8-729-901-01	TRANSISTOR DTC144EK	
D213	8-719-977-22	DIODE DTZ9.1		Q80	8-729-920-74	TRANSISTOR 2SC2412K-QR	
D214	8-719-977-22	DIODE DTZ9.1		Q81	8-729-216-22	TRANSISTOR 2SA1162-G	
D215	8-719-977-22	DIODE DTZ9.1		Q110	8-729-920-74	TRANSISTOR 2SC2412K-QR	
D216	8-719-158-15	DIODE RD5.6S-B		Q111	8-729-216-22	TRANSISTOR 2SA1162-G	
D217	8-719-158-15	DIODE RD5.6S-B		Q112	8-729-920-74	TRANSISTOR 2SC2412K-QR	
D218	8-719-158-15	DIODE RD5.6S-B		Q113	8-729-216-22	TRANSISTOR 2SA1162-G	
D220	8-719-988-62	DIODE 1SS355		Q114	8-729-216-22	TRANSISTOR 2SA1162-G	
D221	8-719-988-62	DIODE 1SS355		Q120	8-729-920-74	TRANSISTOR 2SC2412K-QR	
D222	8-719-977-22	DIODE DTZ9.1		Q121	8-729-920-74	TRANSISTOR 2SC2412K-QR (KV-29C1B)	
D223	8-719-977-22	DIODE DTZ9.1		Q122	8-729-920-74	TRANSISTOR 2SC2412K-QR	
D224	8-719-977-22	DIODE DTZ9.1		Q124	8-729-920-74	TRANSISTOR 2SC2412K-QR (KV-29C1B)	
D225	8-719-977-22	DIODE DTZ9.1		Q130	8-729-216-22	TRANSISTOR 2SA1162-G (KV-29C1B)	
D226	8-719-977-22	DIODE DTZ9.1		Q201	8-729-920-74	TRANSISTOR 2SC2412K-QR	
D227	8-719-977-13	DIODE DTZ6.8C		Q202	8-729-920-74	TRANSISTOR 2SC2412K-QR	
D251	8-719-047-16	DIODE BAS216		Q203	8-729-920-74	TRANSISTOR 2SC2412K-QR	
D320	8-719-977-22	DIODE DTZ9.1		Q204	8-729-920-74	TRANSISTOR 2SC2412K-QR	
D370	8-719-047-16	DIODE BAS216 (KV-29C1B/29C1D/29C1E/29C1K/ 29C1R)		Q205	8-729-901-01	TRANSISTOR DTC144EK	
		< LINE FILTER >		Q206	8-729-216-22	TRANSISTOR 2SA1162-G	
FL101	1-236-071-11	ENCAPSULATED COMPONENT		Q207	8-729-216-22	TRANSISTOR 2SA1162-G	
FL201	1-236-071-11	ENCAPSULATED COMPONENT		Q304	8-729-920-74	TRANSISTOR 2SC2412K-QR	
FL202	1-236-071-11	ENCAPSULATED COMPONENT		Q305	8-729-920-74	TRANSISTOR 2SC2412K-QR	
FL203	1-236-071-11	ENCAPSULATED COMPONENT		Q306	8-729-920-74	TRANSISTOR 2SC2412K-QR	
		< IC >		Q330	8-729-216-22	TRANSISTOR 2SA1162-G	
IC1	8-759-376-75	IC SDA5250M-GEG		Q331	8-729-920-74	TRANSISTOR 2SC2412K-QR	
IC2	8-759-334-20	IC ST24E32M6TR		Q332	8-729-920-74	TRANSISTOR 2SC2412K-QR	
IC3	8-759-167-62	IC TMS27PC010A-15FML		Q1002	8-729-216-22	TRANSISTOR 2SA1162-G	
IC4	8-759-394-57	IC PST593C-MMP-4P				< RESISTOR >	
IC201	8-752-076-06	IC CXA2040Q-T4		JR101	1-216-295-00	METAL GLAZE 0 5% 1/10W	
IC202	8-759-376-80	IC MSP3410-15 (KV-29C1B/29C1E)		JR201	1-216-295-00	METAL GLAZE 0 5% 1/10W	
	8-759-376-56	IC MSP3400C-PS (KV-29C1A/29C1D/29C1E/29C1K/29C1R)		R1	1-216-295-00	METAL GLAZE 0 5% 1/10W	
IC203	8-759-385-76	IC MC14052 BDR2		R2	1-216-025-00	METAL GLAZE 100 5% 1/10W	
IC301	8-752-076-09	IC CXA2000Q-TL		R3	1-216-025-00	METAL GLAZE 100 5% 1/10W	
IC302	8-759-288-85	IC TDA4665T-T		R4	1-216-013-00	METAL GLAZE 33 5% 1/10W	
IC303	8-759-251-56	IC TDA8395T (KV-29C1B/29C1D/29C1E/29C1K/ 29C1R)		R5	1-216-065-00	METAL GLAZE 4.7K 5% 1/10W	
		< COIL >		R7	1-216-041-00	METAL GLAZE 470 5% 1/10W	
L10	1-410-379-31	INDUCTOR CHIP 6.8UH		R8	1-216-065-00	METAL GLAZE 4.7K 5% 1/10W	
L102	1-408-406-00	INDUCTOR 5.6UH (KV-29C1B)		R9	1-216-041-00	METAL GLAZE 470 5% 1/10W	
L111	1-410-993-11	INDUCTOR CHIP 1UH		R10	1-216-041-00	METAL GLAZE 470 5% 1/10W	
L120	1-408-408-00	INDUCTOR 8.2UH		R11	1-216-041-00	METAL GLAZE 470 5% 1/10W	
L121	1-408-397-00	INDUCTOR 1UH		R12	1-216-041-00	METAL GLAZE 470 5% 1/10W	
L122	1-408-408-00	INDUCTOR 8.2UH		R13	1-216-029-00	METAL GLAZE 150 5% 1/10W	
		< TRANSISTOR >		R14	1-216-029-00	METAL GLAZE 150 5% 1/10W	
Q1	8-729-920-74	TRANSISTOR 2SC2412K-QR		R15	1-216-029-00	METAL GLAZE 150 5% 1/10W	
Q4	8-729-920-74	TRANSISTOR 2SC2412K-QR		R16	1-216-025-00	METAL GLAZE 100 5% 1/10W	
Q5	8-729-920-74	TRANSISTOR 2SC2412K-QR		R17	1-216-025-00	METAL GLAZE 100 5% 1/10W	
Q10	8-729-216-22	TRANSISTOR 2SA1162-G		R18	1-216-025-00	METAL GLAZE 100 5% 1/10W	
Q11	8-729-216-22	TRANSISTOR 2SA1162-G		R19	1-216-025-00	METAL GLAZE 100 5% 1/10W	
Q12	8-729-216-22	TRANSISTOR 2SA1162-G		R20	1-216-025-00	METAL GLAZE 100 5% 1/10W	
Q15	8-729-901-01	TRANSISTOR DTC144EK		R21	1-216-025-00	METAL GLAZE 100 5% 1/10W	
Q16	8-729-901-01	TRANSISTOR DTC144EK		R24	1-216-065-00	METAL GLAZE 4.7K 5% 1/10W	
Q17	8-729-901-01	TRANSISTOR DTC144EK		R25	1-216-065-00	METAL GLAZE 4.7K 5% 1/10W	
				R28	1-216-065-00	METAL GLAZE 4.7K 5% 1/10W	
				R29	1-216-065-00	METAL GLAZE 4.7K 5% 1/10W	
				R30	1-216-065-00	METAL GLAZE 4.7K 5% 1/10W	
				R31	1-216-065-00	METAL GLAZE 4.7K 5% 1/10W	
				R32	1-216-025-00	METAL GLAZE 100 5% 1/10W	
				R33	1-216-025-00	METAL GLAZE 100 5% 1/10W	

A

REF.NO.	PART NO.	DESCRIPTION	REMARK	REF.NO.	PART NO.	DESCRIPTION	REMARK
R34	1-216-025-00	METAL GLAZE	100 5% 1/10W	R106	1-216-073-00	METAL GLAZE	10K 5% 1/10W
R35	1-216-025-00	METAL GLAZE	100 5% 1/10W	R110	1-216-073-00	METAL GLAZE	10K 5% 1/10W
R36	1-216-065-00	METAL GLAZE	4.7K 5% 1/10W	R111	1-216-029-00	METAL GLAZE	150 5% 1/10W
R37	1-216-065-00	METAL GLAZE	4.7K 5% 1/10W	R112	1-216-029-00	METAL GLAZE	150 5% 1/10W
R38	1-216-065-00	METAL GLAZE	4.7K 5% 1/10W	R113	1-216-001-00	METAL GLAZE	10 5% 1/10W
R39	1-216-073-00	METAL GLAZE	10K 5% 1/10W	R114	1-216-029-00	METAL GLAZE	150 5% 1/10W
R40	1-216-067-00	METAL GLAZE	5.6K 5% 1/10W	R115	1-216-037-00	METAL GLAZE	330 5% 1/10W
R42	1-216-069-00	METAL GLAZE	6.8K 5% 1/10W	R116	1-216-065-00	METAL GLAZE	4.7K 5% 1/10W
R44	1-216-069-00	METAL GLAZE	6.8K 5% 1/10W	R117	1-216-055-00	METAL GLAZE	1.8K 5% 1/10W
R46	1-216-095-00	METAL GLAZE	82K 5% 1/10W	R118	1-216-071-00	METAL GLAZE	8.2K 5% 1/10W
R47	1-216-057-00	METAL GLAZE	2.2K 5% 1/10W	R119	1-216-033-00	METAL GLAZE	220 5% 1/10W
R48	1-216-121-91	METAL GLAZE	1M 5% 1/10W	R120	1-216-069-00	METAL GLAZE	6.8K 5% 1/10W
R49	1-216-025-00	METAL GLAZE	100 5% 1/10W	R121	1-216-073-00	METAL GLAZE	10K 5% 1/10W
R50	1-216-065-00	METAL GLAZE	4.7K 5% 1/10W	R122	1-216-041-00	METAL GLAZE	470 5% 1/10W
R51	1-216-065-00	METAL GLAZE	4.7K 5% 1/10W	R123	1-216-031-00	METAL GLAZE	180 5% 1/10W
R52	1-216-065-00	METAL GLAZE	4.7K 5% 1/10W	R124	1-216-049-00	METAL GLAZE	1K 5% 1/10W
R53	1-216-065-00	METAL GLAZE	4.7K 5% 1/10W	R125	1-216-081-00	METAL GLAZE	22K 5% 1/10W
R54	1-216-025-00	METAL GLAZE	100 5% 1/10W	R126	1-216-025-00	METAL GLAZE	100 5% 1/10W (KV-29C1B)
R58	1-216-063-91	METAL GLAZE	3.9K 5% 1/10W	R127	1-216-081-00	METAL GLAZE	22K 5% 1/10W
R59	1-216-025-00	METAL GLAZE	100 5% 1/10W	R128	1-216-035-00	METAL GLAZE	270 5% 1/10W
R60	1-216-025-00	METAL GLAZE	100 5% 1/10W	R129	1-216-037-00	METAL GLAZE	330 5% 1/10W
R61	1-216-025-00	METAL GLAZE	100 5% 1/10W	R130	1-216-073-00	METAL GLAZE	10K 5% 1/10W (KV-29C1B)
R62	1-216-025-00	METAL GLAZE	100 5% 1/10W	R131	1-216-073-00	METAL GLAZE	10K 5% 1/10W (KV-29C1B)
R63	1-216-025-00	METAL GLAZE	100 5% 1/10W	R132	1-216-025-00	METAL GLAZE	100 5% 1/10W (KV-29C1B)
R64	1-216-025-00	METAL GLAZE	100 5% 1/10W	R133	1-216-041-00	METAL GLAZE	470 5% 1/10W (KV-29C1B)
R65	1-216-025-00	METAL GLAZE	100 5% 1/10W	R134	1-216-001-00	METAL GLAZE	10 5% 1/10W (KV-29C1B)
R66	1-216-057-00	METAL GLAZE	2.2K 5% 1/10W	R135	1-216-045-00	METAL GLAZE	680 5% 1/10W (KV-29C1B)
R67	1-216-057-00	METAL GLAZE	2.2K 5% 1/10W	R136	1-216-033-00	METAL GLAZE	220 5% 1/10W (KV-29C1B)
R69	1-216-025-00	METAL GLAZE	100 5% 1/10W	R137	1-216-049-00	METAL GLAZE	1K 5% 1/10W (KV-29C1B)
R70	1-216-025-00	METAL GLAZE	100 5% 1/10W	R138	1-216-041-00	METAL GLAZE	470 5% 1/10W (KV-29C1B)
R71	1-216-025-00	METAL GLAZE	100 5% 1/10W	R200	1-216-049-00	METAL GLAZE	1K 5% 1/10W
R72	1-216-025-00	METAL GLAZE	100 5% 1/10W	R201	1-216-033-00	METAL GLAZE	220 5% 1/10W
R73	1-216-025-00	METAL GLAZE	100 5% 1/10W	R202	1-216-033-00	METAL GLAZE	220 5% 1/10W
R74	1-216-025-00	METAL GLAZE	100 5% 1/10W	R203	1-216-025-00	METAL GLAZE	100 5% 1/10W
R75	1-216-025-00	METAL GLAZE	100 5% 1/10W	R204	1-216-025-00	METAL GLAZE	100 5% 1/10W
R76	1-216-025-00	METAL GLAZE	100 5% 1/10W	R205	1-216-093-00	METAL GLAZE	68K 5% 1/10W
R77	1-216-025-00	METAL GLAZE	100 5% 1/10W	R206	1-216-033-00	METAL GLAZE	220 5% 1/10W
R78	1-216-025-00	METAL GLAZE	100 5% 1/10W	R208	1-216-041-00	METAL GLAZE	470 5% 1/10W
R79	1-216-033-00	METAL GLAZE	220 5% 1/10W	R209	1-216-049-00	METAL GLAZE	1K 5% 1/10W
R80	1-216-049-00	METAL GLAZE	1K 5% 1/10W	R210	1-216-017-91	METAL GLAZE	47 5% 1/10W
R81	1-216-081-00	METAL GLAZE	22K 5% 1/10W	R211	1-216-033-00	METAL GLAZE	220 5% 1/10W
R82	1-216-065-00	METAL GLAZE	4.7K 5% 1/10W	R212	1-216-022-00	METAL GLAZE	75 5% 1/10W
R83	1-216-073-00	METAL GLAZE	10K 5% 1/10W	R213	1-216-022-00	METAL GLAZE	75 5% 1/10W
R84	1-216-081-00	METAL GLAZE	22K 5% 1/10W	R214	1-216-025-00	METAL GLAZE	100 5% 1/10W
R85	1-216-073-00	METAL GLAZE	10K 5% 1/10W	R216	1-216-025-00	METAL GLAZE	100 5% 1/10W
R86	1-216-077-00	METAL GLAZE	15K 5% 1/10W	R217	1-216-113-00	METAL GLAZE	470K 5% 1/10W
R87	1-216-081-00	METAL GLAZE	22K 5% 1/10W	R218	1-216-025-00	METAL GLAZE	100 5% 1/10W
R88	1-216-296-00	METAL GLAZE	0 5% 1/8W	R219	1-216-113-00	METAL GLAZE	470K 5% 1/10W
R91	1-216-025-00	METAL GLAZE	100 5% 1/10W	R220	1-216-295-00	METAL GLAZE	0 5% 1/10W
R92	1-216-025-00	METAL GLAZE	100 5% 1/10W	R221	1-216-039-00	METAL GLAZE	390 5% 1/10W
R93	1-216-029-00	METAL GLAZE	150 5% 1/10W				
R94	1-216-001-00	METAL GLAZE	10 5% 1/10W				
R95	1-216-033-00	METAL GLAZE	220 5% 1/10W				
R97	1-216-295-00	METAL GLAZE	0 5% 1/10W				
R98	1-216-295-00	METAL GLAZE	0 5% 1/10W				
R101	1-216-061-00	METAL GLAZE	3.3K 5% 1/10W				
R102	1-216-025-00	METAL GLAZE	100 5% 1/10W				
R103	1-216-025-00	METAL GLAZE	100 5% 1/10W				
R104	1-216-073-00	METAL GLAZE	10K 5% 1/10W				
R105	1-216-113-00	METAL GLAZE	470K 5% 1/10W				

A

REF.NO.	PART NO.	DESCRIPTION	REMARK	REF.NO.	PART NO.	DESCRIPTION	REMARK
R222	1-216-089-00	METAL GLAZE	47K 5% 1/10W	R327	1-216-025-00	METAL GLAZE	100 5% 1/10W
R223	1-216-295-00	METAL GLAZE	0 5% 1/10W	R328	1-216-129-00	METAL GLAZE	2.2M 5% 1/10W
R224	1-216-039-00	METAL GLAZE	390 5% 1/10W	R329	1-216-089-00	METAL GLAZE	47K 5% 1/10W
R225	1-216-089-00	METAL GLAZE	47K 5% 1/10W	R330	1-216-025-00	METAL GLAZE	100 5% 1/10W
R226	1-216-033-00	METAL GLAZE	220 5% 1/10W	R331	1-216-059-00	METAL GLAZE	2.7K 5% 1/10W
R227	1-216-022-00	METAL GLAZE	75 5% 1/10W	R312	1-216-295-00	METAL GLAZE	0 5% 1/10W
R228	1-216-022-00	METAL GLAZE	75 5% 1/10W	R313	1-216-295-00	METAL GLAZE	0 5% 1/10W
R229	1-216-033-00	METAL GLAZE	220 5% 1/10W	R314	1-216-295-00	METAL GLAZE	0 5% 1/10W
R230	1-216-022-00	METAL GLAZE	75 5% 1/10W	R332	1-216-025-00	METAL GLAZE	100 5% 1/10W
R232	1-216-025-00	METAL GLAZE	100 5% 1/10W	R333	1-216-075-00	METAL GLAZE	12K 5% 1/10W
R233	1-216-025-00	METAL GLAZE	100 5% 1/10W	R334	1-216-041-00	METAL GLAZE	470 5% 1/10W
R234	1-216-113-00	METAL GLAZE	470K 5% 1/10W	R335	1-208-806-11	METAL CHIP	10K 0.50% 1/10W
R235	1-216-025-00	METAL GLAZE	100 5% 1/10W	R336	1-216-109-00	METAL GLAZE	330K 5% 1/10W
R236	1-216-113-00	METAL GLAZE	470K 5% 1/10W	R337	1-216-025-00	METAL GLAZE	100 5% 1/10W
R237	1-216-295-00	METAL GLAZE	0 5% 1/10W	R338	1-216-051-00	METAL GLAZE	1.2K 5% 1/10W
R238	1-216-089-00	METAL GLAZE	47K 5% 1/10W	R339	1-216-049-00	METAL GLAZE	1K 5% 1/10W
R239	1-216-039-00	METAL GLAZE	390 5% 1/10W	R340	1-216-025-00	METAL GLAZE	100 5% 1/10W
R240	1-216-295-00	METAL GLAZE	0 5% 1/10W	R341	1-216-025-00	METAL GLAZE	100 5% 1/10W
R241	1-216-089-00	METAL GLAZE	47K 5% 1/10W	R342	1-216-049-00	METAL GLAZE	1K 5% 1/10W
R242	1-216-039-00	METAL GLAZE	390 5% 1/10W	R343	1-216-061-00	METAL GLAZE	3.3K 5% 1/10W
R243	1-216-033-00	METAL GLAZE	220 5% 1/10W	R344	1-216-067-00	METAL GLAZE	5.6K 5% 1/10W
R244	1-216-033-00	METAL GLAZE	220 5% 1/10W	R345	1-216-025-00	METAL GLAZE	100 5% 1/10W
R245	1-216-073-00	METAL GLAZE	10K 5% 1/10W	R346	1-216-063-91	METAL GLAZE	3.9K 5% 1/10W
R246	1-216-053-00	METAL GLAZE	1.5K 5% 1/10W	R347	1-216-025-00	METAL GLAZE	100 5% 1/10W
R247	1-216-053-00	METAL GLAZE	1.5K 5% 1/10W	R348	1-216-025-00	METAL GLAZE	100 5% 1/10W
R249	1-216-001-00	METAL GLAZE	10 5% 1/10W	R349	1-216-025-00	METAL GLAZE	100 5% 1/10W
R255	1-216-025-00	METAL GLAZE	100 5% 1/10W	R350	1-216-042-00	METAL GLAZE	510 5% 1/10W
R256	1-216-025-00	METAL GLAZE	100 5% 1/10W	R351	1-216-053-00	METAL GLAZE	1.5K 5% 1/10W
R270	1-216-022-00	METAL GLAZE	75 5% 1/10W	R352	1-216-077-00	METAL GLAZE	15K 5% 1/10W
R271	1-216-022-00	METAL GLAZE	75 5% 1/10W	R353	1-216-033-00	METAL GLAZE	220 5% 1/10W
R272	1-216-022-00	METAL GLAZE	75 5% 1/10W	R354	1-216-033-00	METAL GLAZE	220 5% 1/10W
R273	1-216-022-00	METAL GLAZE	75 5% 1/10W	R357	1-216-049-00	METAL GLAZE	1K 5% 1/10W
R280	1-216-049-00	METAL GLAZE	1K 5% 1/10W	R370	1-216-295-00	METAL GLAZE	0 5% 1/10W
R281	1-216-089-00	METAL GLAZE	47K 5% 1/10W	R1001	1-216-025-00	METAL GLAZE	100 5% 1/10W
R282	1-216-093-00	METAL GLAZE	68K 5% 1/10W	R1002	1-216-025-00	METAL GLAZE	100 5% 1/10W
R283	1-216-049-00	METAL GLAZE	1K 5% 1/10W	R1010	1-216-295-00	METAL GLAZE	0 5% 1/10W
R284	1-216-089-00	METAL GLAZE	47K 5% 1/10W	R1012	1-216-041-00	METAL GLAZE	470 5% 1/10W
R285	1-216-093-00	METAL GLAZE	68K 5% 1/10W	R1014	1-216-065-00	METAL GLAZE	4.7K 5% 1/10W
R286	1-216-049-00	METAL GLAZE	1K 5% 1/10W	R1020	1-216-097-00	METAL GLAZE	100K 5% 1/10W
R300	1-216-025-00	METAL GLAZE	100 5% 1/10W	R1021	1-216-029-00	METAL GLAZE	150 5% 1/10W
R301	1-216-033-00	METAL GLAZE	220 5% 1/10W	R1022	1-216-029-00	METAL GLAZE	150 5% 1/10W
R302	1-216-295-00	METAL GLAZE	0 5% 1/10W	R1023	1-216-029-00	METAL GLAZE	150 5% 1/10W
R303	1-216-295-00	METAL GLAZE	0 5% 1/10W	R1024	1-216-025-00	METAL GLAZE	100 5% 1/10W
R308	1-216-025-00	METAL GLAZE	100 5% 1/10W	R1026	1-216-025-00	METAL GLAZE	100 5% 1/10W
R309	1-216-033-00	METAL GLAZE	220 5% 1/10W	R1027	1-216-025-00	METAL GLAZE	100 5% 1/10W
R310	1-216-033-00	METAL GLAZE	220 5% 1/10W	R1028	1-216-025-00	METAL GLAZE	100 5% 1/10W
R311	1-216-295-00	METAL GLAZE	0 5% 1/10W				
R312	1-216-295-00	METAL GLAZE	0 5% 1/10W			< TUNER >	
R313	1-216-295-00	METAL GLAZE	0 5% 1/10W	TU101	1-693-338-11	TUNER/VIF (AEP)	
R314	1-216-295-00	METAL GLAZE	0 5% 1/10W			(KV-29C1A/29C1D/29C1D 1/29C1E/29C1K/29C1R)	
R315	1-216-295-00	METAL GLAZE	0 5% 1/10W			1-693-340-11	TUNER/VIF (FR) (KV-29C1B)
R316	1-216-033-00	METAL GLAZE	220 5% 1/10W				
R318	1-216-689-11	METAL GLAZE	39K 5% 1/10W				
R319	1-216-081-00	METAL GLAZE	22K 5% 1/10W				
R320	1-216-025-00	METAL GLAZE	100 5% 1/10W			< CRYSTAL >	
R321	1-216-025-00	METAL GLAZE	100 5% 1/10W	X1	1-767-120-21	VIBRATOR, CERAMIC	
R322	1-216-025-00	METAL GLAZE	100 5% 1/10W	X201	1-760-628-11	VIBRATOR, CRYSTAL 18.432MHz	
R323	1-216-033-00	METAL GLAZE	220 5% 1/10W	X301	1-567-504-11	OSCILLATOR, CRYSTAL	
R324	1-216-063-91	METAL GLAZE	3.9K 5% 1/10W	X302	1-567-505-11	OSCILLATOR, CRYSTAL	
R326	1-216-025-00	METAL GLAZE	100 5% 1/10W	X303	1-767-127-11	VIBRATOR, CERAMIC	

IF (KV-29C1A/29C1D/29C1D 1/
29C1E/29C1K/29C1R)

IF (KV-29C1B)

REF.NO.	PART NO.	DESCRIPTION	REMARK
A-1652-037-A	IF BOARD, COMPLETE	(KV-29C1A/29C1D/ ***** 29C1D 1/29C1E/ 29C1K/29C1R)	
< CAPACITOR >			
C01	1-164-337-11	CERAMIC CHIP 2.2MF	16V
C02	1-164-337-11	CERAMIC CHIP 2.2MF	16V
C03	1-104-957-11	ELECT 47MF	20% 16V
C04	1-135-259-11	TANTAL. CHIP 10MF	20% 6.3V
C05	1-164-004-11	CERAMIC CHIP 0.1MF	10% 25V
C06	1-164-005-11	CERAMIC CHIP 0.47MF	16V
C08	1-164-232-11	CERAMIC CHIP 0.01MF	10% 50V
C09	1-164-004-11	CERAMIC CHIP 0.1MF	10% 25V
C10	1-164-004-11	CERAMIC CHIP 0.1MF	10% 25V
C11	1-164-004-11	CERAMIC CHIP 0.1MF	10% 25V
C15	1-124-282-00	ELECT 22MF	20% 25V
C16	1-162-638-11	CERAMIC CHIP 1MF	16V
C18	1-164-337-11	CERAMIC CHIP 2.2MF	16V
C19	1-124-937-11	ELECT 10MF	20% 16V
< FILTER >			
CF01	1-404-134-00	TRAP, CERAMIC (5.5MHZ)	
SWF04	1-767-084-11	FILTER, SURFACE WAVE	
< IC >			
IC01	8-759-385-26	IC TDA4472-CFLG3	
< COIL >			
L02	1-408-408-00	INDUCTOR 8.2UH	
L04	1-408-419-00	INDUCTOR 68UH	
L08	1-410-992-11	INDUCTOR CHIP 0.82UH	
< VARIABLE COIL >			
LV01	1-411-874-11	COIL	
< TRANSISTOR >			
Q01	8-729-216-22	TRANSISTOR 2SA1162-G	
< RESISTOR >			
JR01	1-216-296-91	METAL GLAZE 0 5%	1/8W
JR02	1-216-296-91	METAL GLAZE 0 5%	1/8W
JR03	1-216-295-00	METAL GLAZE 0 5%	1/10W
JR04	1-216-296-91	METAL GLAZE 0 5%	1/8W
JR05	1-216-295-00	METAL GLAZE 0 5%	1/10W
JR07	1-216-295-00	METAL GLAZE 0 5%	1/10W
R01	1-216-029-00	METAL GLAZE 150 5%	1/10W
R02	1-216-089-91	METAL GLAZE 47K 5%	1/10W
R03	1-216-089-91	METAL GLAZE 47K 5%	1/10W
R04	1-216-057-00	METAL GLAZE 2.2K 5%	1/10W
R05	1-216-081-00	METAL GLAZE 22K 5%	1/10W
R06	1-216-057-00	METAL GLAZE 2.2K 5%	1/10W
R07	1-216-025-91	METAL GLAZE 100 5%	1/10W
R08	1-216-174-00	METAL GLAZE 100 5%	1/8W
R09	1-216-045-00	METAL GLAZE 680 5%	1/10W
R10	1-216-041-00	METAL GLAZE 470 5%	1/10W
R11	1-216-051-00	METAL GLAZE 1.2K 5%	1/10W
R23	1-216-049-91	METAL GLAZE 1K 5%	1/10W
R24	1-216-295-91	METAL GLAZE 0 5%	1/10W

REF.NO.	PART NO.	DESCRIPTION	REMARK
R25	1-216-057-00	METAL GLAZE 2.2K 5%	1/10W
R021	1-216-174-00	METAL GLAZE 100 5%	1/8W
< VARIABLE RESISTOR >			
RV01	1-226-703-11	RES, ADJ, METAL GLAZE 10K	

A-1652-036-A	IF BOARD, COMPLETE	(KV-29C1B) *****	
< CAPACITOR >			
C01	1-162-638-11	CERAMIC CHIP 1MF	16V
C02	1-164-337-11	CERAMIC CHIP 2.2MF	16V
C03	1-104-957-11	ELECT 47MF	20% 16V
C04	1-135-259-11	TANTAL. CHIP 10MF	20% 6.3V
C05	1-164-004-11	CERAMIC CHIP 0.1MF	10% 25V
C06	1-164-005-11	CERAMIC CHIP 0.47MF	16V
C08	1-164-232-11	CERAMIC CHIP 0.01MF	10% 50V
C09	1-164-004-11	CERAMIC CHIP 0.1MF	10% 25V
C10	1-164-004-11	CERAMIC CHIP 0.1MF	10% 25V
C11	1-164-004-11	CERAMIC CHIP 0.1MF	10% 25V
C12	1-164-232-11	CERAMIC CHIP 0.01MF	10% 50V
C13	1-164-232-11	CERAMIC CHIP 0.01MF	10% 50V
C14	1-164-232-11	CERAMIC CHIP 0.01MF	10% 50V
C15	1-104-957-11	ELECT 47MF	20% 16V
C16	1-162-638-11	CERAMIC CHIP 1MF	16V
C17	1-163-243-11	CERAMIC CHIP 47PF	5% 50V
C18	1-164-337-11	CERAMIC CHIP 2.2MF	16V
C20	1-124-937-11	ELECT 10MF	20% 16V
C21	1-164-506-11	CERAMIC CHIP 4.7MF	16V
< FILTER >			
CF01	1-409-430-11	TRAP, CERAMIC	
SWF01	1-579-273-11	FILTER, SURFACE WAVE	
SWF02	1-760-329-11	FILTER, SURFACE WAVE	
SWF03	1-767-083-11	FILTER, SURFACE WAVE	
< TRIMMER >			
CT01	1-760-662-11	TRAP, CERAMIC	
< IC >			
IC01	8-759-069-36	IC MC74HC4046AF	
< COIL >			
L02	1-408-406-00	INDUCTOR 5.6UH	
L04	1-408-419-00	INDUCTOR 68UH	
L05	1-410-987-11	INDUCTOR CHIP 0.33UH	
L06	1-408-399-00	INDUCTOR 1.5UH	
< VARIABLE COIL >			
LV01	1-411-874-11	COIL	
< TRANSISTOR >			
Q01	8-729-216-22	TRANSISTOR 2SA1162-G	
Q02	8-729-035-11	TRANSISTOR BF799-GEG	
Q03	8-729-035-11	TRANSISTOR BF799-GEG	
Q04	8-729-901-01	TRANSISTOR DTC144EK	

Les composants identifiés par une trame et une marque **A** sont critiques pour la sécurité. Ne les remplacer que par une pièce portant le numéro spécifié.

The components identified by shading and marked **A** are critical for safety. Replace only with the part number specified.

IF (KV-29C1B)

C

REF.NO.	PART NO.	DESCRIPTION	REMARK
< RESISTOR >			
JR01	1-216-296-91	METAL GLAZE 0 5% 1/8W	
JR02	1-216-296-91	METAL GLAZE 0 5% 1/8W	
JR03	1-216-295-00	METAL GLAZE 0 5% 1/10W	
JR04	1-216-296-91	METAL GLAZE 0 5% 1/8W	
JR05	1-216-295-00	METAL GLAZE 0 5% 1/10W	
JR07	1-216-295-00	METAL GLAZE 0 5% 1/10W	
R01	1-216-029-00	METAL GLAZE 150 5% 1/10W	
R02	1-216-089-91	METAL GLAZE 47K 5% 1/10W	
R03	1-216-089-91	METAL GLAZE 47K 5% 1/10W	
R04	1-216-057-00	METAL GLAZE 2.2K 5% 1/10W	
R05	1-216-081-00	METAL GLAZE 22K 5% 1/10W	
R06	1-216-057-00	METAL GLAZE 2.2K 5% 1/10W	
R07	1-216-025-91	METAL GLAZE 100 5% 1/10W	
R08	1-216-174-00	METAL GLAZE 100 5% 1/8W	
R09	1-216-045-00	METAL GLAZE 680 5% 1/10W	
R10	1-216-041-00	METAL GLAZE 470 5% 1/10W	
R11	1-216-051-00	METAL GLAZE 1.2K 5% 1/10W	
R12	1-216-063-91	METAL GLAZE 3.9K 5% 1/10W	
R13	1-216-061-00	METAL GLAZE 3.3K 5% 1/10W	
R14	1-216-023-00	METAL GLAZE 82 5% 1/10W	
R15	1-216-017-91	METAL GLAZE 47 5% 1/10W	
R16	1-216-033-00	METAL GLAZE 220 5% 1/10W	
R17	1-216-017-91	METAL GLAZE 47 5% 1/10W	
R18	1-216-013-00	METAL GLAZE 33 5% 1/10W	
R20	1-216-222-00	METAL GLAZE 10K 5% 1/8W	
R23	1-216-049-91	METAL GLAZE 1K 5% 1/10W	
R25	1-216-057-00	METAL GLAZE 2.2K 5% 1/10W	
R21	1-216-174-00	METAL GLAZE 100 5% 1/8W	

< VARIABLE RESISTOR >

RV01	1-226-703-11	RES, ADJ, METAL GLAZE 10K	
RV02	1-226-703-11	RES, ADJ, METAL GLAZE 10K	

*A-1638-082-A C BOARD, COMPLETE

< CAPACITOR >

C702	1-102-115-00	CERAMIC 560PF 10% 50V	
C703	1-102-116-00	CERAMIC 680PF 10% 50V	
C708	1-162-114-00	CERAMIC 0.0047MF 2KV	
C710	1-107-652-11	ELECT 10MF 20% 250V	
C712	1-102-116-00	CERAMIC 680PF 10% 50V	
C714	1-126-967-11	ELECT 47MF 20% 16V	
C717	1-102-114-00	CERAMIC 470PF 10% 50V	
C718	1-102-114-00	CERAMIC 470PF 10% 50V	
C719	1-102-114-00	CERAMIC 470PF 10% 50V	
C722	1-101-880-00	CERAMIC 47PF 5% 50V	
C723	1-101-880-00	CERAMIC 47PF 5% 50V	
C724	1-101-880-00	CERAMIC 47PF 5% 50V	

< CONNECTOR >

CN701	1-778-037-11	PIN, CONNECTOR 6P	
CN702	1-695-915-11	TAB (CONTACT)	
CN703	*1-568-882-51	PIN, CONNECTOR 7P	

REF.NO.	PART NO.	DESCRIPTION	REMARK
< DIODE >			
D701	8-719-109-72	DIODE RD3.9ES-B2	
D702	8-719-991-33	DIODE 1SS133T-77	
D706	8-719-991-33	DIODE 1SS133T-77	
D707	8-719-991-33	DIODE 1SS133T-77	
D708	8-719-991-33	DIODE 1SS133T-77	
D709	8-719-991-33	DIODE 1SS133T-77	
D710	8-719-991-33	DIODE 1SS133T-77	
D711	8-719-302-43	DIODE EL1Z	
D714	8-719-991-33	DIODE 1SS133T-77	
D715	8-719-991-33	DIODE 1SS133T-77	
D716	8-719-991-33	DIODE 1SS133T-77	
D717	8-719-991-33	DIODE 1SS133T-77	
D718	8-719-991-33	DIODE 1SS133T-77	
D719	8-719-991-33	DIODE 1SS133T-77	
D720	8-719-991-33	DIODE 1SS133T-77	

< CRT SOCKET >

J701	1-526-990-22	SOCKET, CRT	
------	--------------	-------------	--

< COIL >

L704	1-408-609-41	INDUCTOR 33UH	
------	--------------	---------------	--

< TRANSISTOR >

Q702	8-729-119-78	TRANSISTOR 2SC2785-HFE	
Q703	8-729-906-70	TRANSISTOR BF871-127	
Q704	8-729-200-17	TRANSISTOR 2SA1091-O	
Q705	8-729-119-78	TRANSISTOR 2SC2785-HFE	
Q706	8-729-906-70	TRANSISTOR BF871-127	
Q707	8-729-200-17	TRANSISTOR 2SA1091-O	
Q708	8-729-119-78	TRANSISTOR 2SC2785-HFE	
Q709	8-729-906-70	TRANSISTOR BF871-127	
Q710	8-729-200-17	TRANSISTOR 2SA1091-O	
Q711	8-729-173-38	TRANSISTOR 2SA733-K	

< RESISTOR >

R704	1-216-486-00	METAL OXIDE 8.2K 5% 3W	F
R705	1-202-822-00	SOLID 2.2K 10% 1/2W	
R706	1-247-815-91	CARBON 220 5% 1/4W	
R707	1-249-407-11	CARBON 150 5% 1/4W	
R709	1-202-844-00	SOLID 330K 10% 1/2W	
R711	1-249-420-11	CARBON 1.8K 5% 1/4W	
R712	1-202-822-00	SOLID 2.2K 10% 1/2W	
R714	1-216-486-00	METAL OXIDE 8.2K 5% 3W	F
R715	1-249-417-11	CARBON 1K 5% 1/4W	
R716	1-247-815-91	CARBON 220 5% 1/4W	
R717	1-249-407-11	CARBON 150 5% 1/4W	
R718	1-202-814-11	SOLID 33K 10% 1/2W	
R720	1-249-420-11	CARBON 1.8K 5% 1/4W	
R722	1-202-848-00	SOLID 680K 10% 1/2W	
R723	1-249-417-11	CARBON 1K 5% 1/4W	
R724	1-202-846-00	SOLID 470K 10% 1/2W	
R726	1-202-822-00	SOLID 2.2K 10% 1/2W	
R727	1-247-815-91	CARBON 220 5% 1/4W	
R728	1-216-350-11	METAL OXIDE 1.2 5% 1W	F
R729	1-249-407-11	CARBON 150 5% 1/4W	
R731	1-249-420-11	CARBON 1.8K 5% 1/4W	
R733	1-249-417-11	CARBON 1K 5% 1/4W	
R734	1-247-807-31	CARBON 100 5% 1/4W	
R735	1-249-417-11	CARBON 1K 5% 1/4W	

Les composants identifiés par une trame et une marque  sont critiques pour la sécurité. Ne les remplacer que par une pièce portant le numéro spécifique.

The components identified by shading and marked  are critical for safety. Replace only with the part number specified.





REF.NO.	PART NO.	DESCRIPTION	REMARK	REF.NO.	PART NO.	DESCRIPTION	REMARK
R736	1-216-486-00	METAL OXIDE 8.2K 5% 3W	F	C503	1-136-165-00	FILM 0.1MF 5%	50V
R739	1-249-417-11	CARBON 1K 5% 1/4W		C504	1-102-824-00	CERAMIC 470PF 5%	50V
R740	1-249-417-11	CARBON 1K 5% 1/4W		C506	1-126-941-11	ELECT 470MF 20%	25V
R741	1-202-549-00	SOLID 100 20% 1/2W		C507	1-109-953-11	ELECT 2.2MF 20%	50V
R744	1-249-421-11	CARBON 2.2K 5% 1/4W		C509	1-136-165-00	FILM 0.1MF 5%	50V
R745	1-249-421-11	CARBON 2.2K 5% 1/4W		C510	1-126-969-11	ELECT 220MF 20%	50V
R746	1-249-421-11	CARBON 2.2K 5% 1/4W		C511	1-136-202-11	FILM 0.33MF 5%	63V
R747	1-249-437-11	CARBON 47K 5% 1/4W		C513	1-106-220-00	MYLAR 0.1MF 10%	100V
R748	1-249-417-11	CARBON 1K 5% 1/4W		C514	1-136-165-00	FILM 0.1MF 5%	50V
R749	1-249-435-11	CARBON 33K 5% 1/4W		C515	1-126-941-11	ELECT 470MF 20%	25V
< VARIABLE RESISTOR >				C517	1-126-941-11	ELECT 470MF 20%	25V
RV701	1-230-641-11	RES, ADJ, METAL GLAZE 2.2M		C518	1-102-228-00	CERAMIC 470PF 10%	500V
RV702	1-241-656-21	RES, ADJ, METAL FILM 110M		C519	1-102-228-00	CERAMIC 470PF 10%	500V
*****				C520	1-126-941-11	ELECT 470MF 20%	25V
*A-1640-214-A D2 BOARD, COMPLETE				C521	1-124-006-11	ELECT 10MF 20%	25V
*****				C522	1-126-964-11	ELECT 10MF 20%	50V
< CAPACITOR >				C523	1-136-165-00	FILM 0.1MF 5%	50V
C1801	1-126-967-11	ELECT 47MF 20% 50V		C600	1-113-890-51	CERAMIC 0.0022MF 20%	250V
C1803	1-137-368-11	FILM 0.0047MF 5% 50V		C601	1-161-964-91	CERAMIC 0.0047MF 250V	
C1804	1-126-964-11	ELECT 10MF 20% 50V		C602	1-161-964-91	CERAMIC 0.0047MF 250V	
C1807	1-137-366-11	FILM 0.0022MF 5% 50V		C603	1-125-555-11	ELECT 330MF 20%	400V
< CONNECTOR >				C604	1-126-968-11	ELECT 100MF 20%	50V
CN1801	1-573-299-21	CONNECTOR, BOARD TO BOARD 10P		C605	1-107-929-11	ELECT 10MF 20%	100V
CN1803	*1-568-878-51	PIN, CONNECTOR 3P		C606	1-162-318-11	CERAMIC 0.001MF 10%	500V
< DIODE >				C607	1-104-666-11	ELECT 220MF 20%	25V
D1802	8-719-110-17	DIODE RD10ESB2		C608	1-109-880-11	FILM 0.0015MF 3%	2KV
< IC >				C611	1-102-228-00	CERAMIC 470PF 10%	500V
IC1801	8-759-701-59	IC NJM78M09FA		C612	1-111-160-91	ELECT 22MF 20%	100V
IC1802	8-759-603-37	IC M5216P		C613	1-124-347-00	ELECT 100MF 20%	160V
< LINK IC >				C614	1-128-526-11	ELECT 100MF 20%	25V
JW1802	1-532-605-91	LINK, IC (0.4A)		C615	1-111-067-11	ELECT 0.001MF 20%	25V
< RESISTOR >				C616	1-111-067-11	ELECT 0.001MF 20%	25V
R1802	1-249-426-11	CARBON 5.6K 5% 1/4W		C617	1-128-339-51	ELECT 2200MF 20%	16V
R1807	1-247-883-00	CARBON 150K 5% 1/4W		C618	1-136-165-00	FILM 0.1MF 5%	50V
R1809	1-249-429-11	CARBON 10K 5% 1/4W		C619	1-102-228-00	CERAMIC 470PF 10%	500V
R1810	1-249-429-11	CARBON 10K 5% 1/4W		C620	1-102-228-00	CERAMIC 470PF 10%	500V
R1811	1-249-429-11	CARBON 10K 5% 1/4W		C621	1-136-165-00	FILM 0.1MF 5%	50V
R1812	1-249-429-11	CARBON 10K 5% 1/4W		C622	1-107-925-11	ELECT 1MF 20%	100V
*****				C623	1-104-666-11	ELECT 220MF 20%	25V
*A-1642-165-A D BOARD, COMPLETE (KV-29C1A/29C1B/				C624	1-136-165-00	FILM 0.1MF 5%	50V
***** 29C1D/29C1E/				C625	1-126-967-11	ELECT 47MF 20%	50V
***** 29C1K/29C1R)				C626	1-104-666-11	ELECT 220MF 20%	25V
*A-1642-188-A D BOARD, COMPLETE (KV-29C1D 1)				C628	1-126-964-11	ELECT 10MF 20%	50V
*****				C629	1-111-097-11	ELECT 2200MF 20%	35V
4-201-023-11 SPACER, INSULATING				C630	1-111-097-11	ELECT 2200MF 20%	35V
4-202-373-01 SPRING, IC				C631	1-126-965-11	ELECT 22MF 20%	50V
< CAPACITOR >				C633	1-107-564-11	FILM 0.22MF 20%	300V
C502	1-102-824-00	CERAMIC 470PF 5% 50V		C634	1-107-564-11	FILM 0.22MF 20%	300V
				C635	1-107-564-11	FILM 0.22MF 20%	300V
				C636	1-113-890-51	CERAMIC 0.0022MF 20%	250V
				C638	1-136-203-11	FILM 0.01MF 5%	630V
				C640	1-106-220-00	MYLAR 0.1MF 10%	100V
				C644	1-137-043-11	FILM 0.0047MF 10%	400V
				C647	1-162-116-00	CERAMIC 680PF 10%	2KV
				C651	1-102-228-00	CERAMIC 470PF 10%	500V
				C800	1-137-368-11	FILM 0.0047MF 5%	50V
				C801	1-137-372-11	FILM 0.022MF 5%	50V
				C802	1-136-161-00	FILM 0.047MF 5%	50V
				C804	1-136-165-00	FILM 0.1MF 5%	50V
				C805	1-136-207-11	FILM 0.047MF 10%	250V

Les composants identifiés par une trame et une marque  sont critiques pour la sécurité. Ne les remplacer que par une pièce portant le numéro spécifié.

The components identified by shading and marked  are critical for safety. Replace only with the part number specified.



REF.NO.	PART NO.	DESCRIPTION	REMARK	REF.NO.	PART NO.	DESCRIPTION	REMARK
C806	1-104-999-11	MYLAR 0.1MF	10% 200V	C1218	1-126-934-11	ELECT 220MF	20% 16V
C807	1-136-109-00	FILM 0.68MF	5% 200V			< CONNECTOR >	
C808	1-137-205-11	FILM 0.1MF	5% 400V	CN600	1-508-786-00	PIN, CONNECTOR (5MM PITCH) 2P	
C810	1-107-683-11	ELECT 2.2MF	250V	CN601 	1-508-765-11	PIN, CONNECTOR (5MM PITCH) 3P	
C811	1-102-212-00	CERAMIC 820PF	10% 500V	CN603 	*1-580-844-11	PIN, CONNECTOR (POWER)	
C812	1-136-125-00	FILM 0.68MF	5% 400V	CN800	*1-580-798-11	CONNECTOR PIN (DY) 6P	
C813	1-129-722-00	FILM 0.047MF	10% 630V	CN801	*1-573-296-21	CONNECTOR, BOARD TO BOARD 10P	
C814	1-136-565-11	FILM 0.015MF	3% 1.4KV	CN803	1-695-915-11	TAB (CONTACT)	
C815	1-136-562-11	MYLAR 0.0082MF	10% 400V	CN804	1-778-037-11	PIN, CONNECTOR 6P	
C816	1-161-754-00	CERAMIC 0.001MF	10% 2KV	CN807	1-568-878-51	PIN, CONNECTOR 3P	
C817	1-161-754-00	CERAMIC 0.001MF	10% 2KV	CN900	1-568-678-11	TERMINAL BLOCK, S 3P (KV-29C1A/29C1B/29C1D/29C1E/29C1K/ 29C1R)	
C818	1-162-134-11	CERAMIC 470PF	10% 2KV	CN902	1-695-299-11	CONNECTOR, BOARD TO BOARD 50P	
C819	1-136-208-11	FILM 0.068MF	10% 250V	CN1401	*1-568-880-51	PIN, CONNECTOR 5P	
C820	1-102-114-00	CERAMIC 470PF	10% 50V	CN1408	*1-568-879-11	PIN, CONNECTOR 4P	
C821	1-162-114-00	CERAMIC 0.0047MF	2KV	CN1420	1-568-878-51	PIN, CONNECTOR 3P	
C822	1-107-662-11	ELECT 22MF	20% 250V			< DIODE >	
C824	1-123-024-21	ELECT 33MF	160V	D500	8-719-109-85	DIODE RD5.1ES-B2	
C829	1-124-902-00	ELECT 0.47MF	20% 50V	D502	8-719-979-85	DIODE EGP20G	
C830	1-124-902-00	ELECT 0.47MF	20% 50V	D503	8-719-979-85	DIODE EGP20G	
C832	1-124-903-11	ELECT 1MF	20% 50V	D504	8-719-991-33	DIODE 1SS133T-77	
C834	1-128-551-11	ELECT 22MF	20% 25V	D505	8-719-982-03	DIODE MTZJ-3.6A	
C835	1-162-318-11	CERAMIC 0.001MF	10% 500V	D506	8-719-991-33	DIODE 1SS133T-77	
C836	1-162-117-00	CERAMIC 100PF	10% 500V	D507	8-719-109-85	DIODE RD5.1ES-B2	
C838	1-102-228-00	CERAMIC 470PF	10% 500V	D600	8-719-510-53	DIODE D4SB60L	
C839	1-136-189-00	FILM 0.1MF	10% 250V	D601	8-719-046-77	DIODE EMI-V1	
C845	1-102-110-00	CERAMIC 220PF	10% 50V	D603	8-719-109-97	DIODE RD6.8ES-B2	
C901	1-101-810-00	CERAMIC 100PF	5% 500V (KV-29C1A/29C1B/29C1D/29C1E/29C1K/ 29C1R)	D604	8-719-046-75	DIODE EU-1-V1	
C902	1-137-372-11	FILM 0.022MF	5% 50V	D605	8-719-302-43	DIODE EL1Z	
C903	1-137-372-11	FILM 0.022MF	5% 50V	D606	8-719-302-43	DIODE EL1Z	
C904	1-104-665-11	ELECT 100MF	20% 25V	D607	8-719-046-78	DIODE EG-1Z-V1	
C905	1-126-964-11	ELECT 10MF	20% 50V	D608	8-719-312-94	DIODE EU2-V1	
C906	1-126-964-11	ELECT 10MF	20% 50V (KV-29C1A/29C1B/29C1D/29C1E/29C1K/ 29C1R)	D609	8-719-301-64	DIODE RU4DS	
C907	1-126-964-11	ELECT 10MF	20% 50V (KV-29C1A/29C1B/29C1D/29C1E/29C1K/ 29C1R)	D610	8-719-046-74	DIODE AU-01Z-V1	
C908	1-126-964-11	ELECT 10MF	20% 50V (KV-29C1A/29C1B/29C1D/29C1E/29C1K/ 29C1R)	D611	8-719-045-48	DIODE FML-G12S	
C911	1-126-964-11	ELECT 10MF	20% 50V	D612	8-719-046-76	DIODE RU3YX-V1	
C913	1-101-810-00	CERAMIC 100PF	5% 500V (KV-29C1A/29C1B/29C1D/29C1E/29C1K/ 29C1R)	D613	8-719-045-48	DIODE FML-G12S	
C1200	1-136-165-00	FILM 0.1MF	5% 50V	D614	8-719-045-48	DIODE FML-G12S	
C1201	1-136-173-00	FILM 0.47MF	5% 50V	D615	8-719-046-75	DIODE EU-1-V1	
C1202	1-136-173-00	FILM 0.47MF	5% 50V	D616	8-719-110-03	DIODE RD7.5ESB2	
C1203	1-136-169-00	FILM 0.22MF	5% 50V	D617	8-719-991-33	DIODE 1SS133T-77	
C1204	1-136-169-00	FILM 0.22MF	5% 50V	D618	8-719-991-33	DIODE 1SS133T-77	
C1205	1-101-005-00	CERAMIC 0.022MF	50V	D619	8-719-991-33	DIODE 1SS133T-77	
C1206	1-101-005-00	CERAMIC 0.022MF	50V	D620	8-719-991-33	DIODE 1SS133T-77	
C1207	1-126-933-11	ELECT 100MF	20% 16V	D622	8-719-923-60	DIODE MTZJ-T-77-9.1A	
C1208	1-126-963-11	ELECT 4.7MF	20% 50V	D625	8-719-991-33	DIODE 1SS133T-77	
C1209	1-126-963-11	ELECT 4.7MF	20% 50V	D626	8-719-046-74	DIODE AU-01Z-V1	
C1214	1-126-933-11	ELECT 100MF	20% 16V	D631	8-719-109-93	DIODE RD6.2ES-B2	
C1215	1-136-173-00	FILM 0.47MF	5% 50V	D800	8-719-991-33	DIODE 1SS133T-77	
C1216	1-137-366-11	FILM 0.0022MF	5% 50V	D801	8-719-991-33	DIODE 1SS133T-77	
C1217	1-137-366-11	FILM 0.0022MF	5% 50V	D802	8-719-991-33	DIODE 1SS133T-77	
				D803	8-719-908-03	DIODE GP08D	
				D807	8-719-302-43	DIODE EL1Z	
				D808	8-719-908-03	DIODE GP08D	
				D809	8-719-018-82	DIODE RGP02-20EL-6394	
				D810	8-719-302-43	DIODE EL1Z	
				D812	8-719-038-49	DIODE FMS-3FU-LF027-1	

Les composants identifiés par une trame et une marque  sont critiques pour la sécurité. Ne les remplacer que par une pièce portant le numéro spécifique.

The components identified by shading and marked  are critical for safety. Replace only with the part number specified.



REF.NO.	PART NO.	DESCRIPTION	REMARK	REF.NO.	PART NO.	DESCRIPTION	REMARK
D815	8-719-908-03	DIODE GP08D		L615	1-412-529-11	INDUCTOR 22UH	
D817	8-719-109-89	DIODE RD5.6ESB2		L616	1-412-533-21	INDUCTOR 47UH	
D901	8-719-030-11	DIODE SLA-570KT3F (KV-29C1A/29C1B/29C1D/29C1E/29C1K/ 29C1R)		L801	1-459-111-00	COIL, DRAM CORE (CDI)	
D902	8-719-923-60	DIODE MTZJ-T-77-9.1A (KV-29C1A/29C1B/29C1D/29C1E/29C1K/ 29C1R)		L802	1-459-104-00	COIL, WITH CORE	
D903	8-719-923-60	DIODE MTZJ-T-77-9.1A (KV-29C1A/29C1B/29C1D/29C1E/29C1K/ 29C1R)		L803	1-420-872-00	COIL, AIR-CORE	
D904	8-719-923-60	DIODE MTZJ-T-77-9.1A (KV-29C1A/29C1B/29C1D/29C1E/29C1K/ 29C1R)		L804	1-406-903-11	COIL, HORIZONTAL LINEARITY	
D905	8-719-923-60	DIODE MTZJ-T-77-9.1A (KV-29C1A/29C1B/29C1D/29C1E/29C1K/ 29C1R)		L805	1-406-675-11	COIL, CHOKE 4.7MMH	
D906	8-719-923-60	DIODE MTZJ-T-77-9.1A (KV-29C1A/29C1B/29C1D/29C1E/29C1K/ 29C1R)		L809	1-412-533-21	INDUCTOR 47UH	
D1201	8-719-109-72	DIODE RD3.9ES-B2		L811	1-406-979-11	COIL, CHOKE 220UH	
		< FUSE >		L813	1-412-552-21	INDUCTOR 2.2MMH	
F601	1-576-232-21	FUSE (H.B.C.) 5A/250V		L901	1-408-603-31	INDUCTOR 10UH	
	1-533-230-11	HOLDER, FUSE ;F601		L902	1-408-603-31	INDUCTOR 10UH	
		< FERRITE BEAD >		L903	1-408-409-00	INDUCTOR 10UH (KV-29C1A/29C1B/29C1D/29C1E/29C1K/ 29C1R)	
FB600	1-410-397-21	FERRITE BEAD INDUCTOR 1.1UH		L904	1-408-409-00	INDUCTOR 10UH (KV-29C1A/29C1B/29C1D/29C1E/29C1K/ 29C1R)	
FB601	1-410-397-21	FERRITE BEAD INDUCTOR 1.1UH				< IC LINK >	
FB602	1-410-397-21	FERRITE BEAD INDUCTOR 1.1UH		PS600	1-532-686-91	LINK, IC 2.7A (ICP-F75)	
FB604	1-410-396-41	FERRITE BEAD INDUCTOR 0.45UH		PS601	1-532-686-91	LINK, IC 2.7A (ICP-F75)	
FB605	1-410-396-41	FERRITE BEAD INDUCTOR 0.45UH		PS602	1-532-686-91	LINK, IC 2.7A (ICP-F75)	
FB606	1-410-397-21	FERRITE BEAD INDUCTOR 1.1UH		PS603	1-532-686-91	LINK, IC 2.7A (ICP-F75)	
FB607	1-410-397-21	FERRITE BEAD INDUCTOR 1.1UH				< TRANSISTOR >	
FB608	1-410-396-41	FERRITE BEAD INDUCTOR 0.45UH		Q501	8-729-119-78	TRANSISTOR 2SC2785-HFE	
FB800	1-410-396-41	FERRITE BEAD INDUCTOR 0.45UH		Q502	8-729-119-76	TRANSISTOR 2SA1175-HFE	
		< IC >		Q503	8-729-900-89	TRANSISTOR DTC144ES	
IC500	8-759-192-71	IC STV9379		Q601	8-729-025-04	TRANSISTOR 2SC3852A	
IC600	8-749-010-84	IC STR-S6708		Q602	8-729-320-28	TRANSISTOR 2SA1667	
IC601	8-749-924-92	IC TLP721(D4-)		Q603	8-729-802-78	TRANSISTOR 2SC3502-E	
IC602	8-749-920-61	IC SE135N		Q604	8-729-024-35	TRANSISTOR 2SC2808STP-R	
IC603	8-759-144-82	IC μPC2405HF		Q605	8-729-119-78	TRANSISTOR 2SC2785-HFE	
IC604	8-759-510-52	IC L4941BV		Q606	8-729-900-65	TRANSISTOR DTA144ES	
IC606	8-759-267-25	IC LM2940T-9.0		Q607	8-729-119-78	TRANSISTOR 2SC2785-HFE	
IC800	8-759-103-93	IC μPC393C		Q800	8-729-119-78	TRANSISTOR 2SC2785-HFE	
IC900	8-747-905-11	RAY CATCHER ELEMENT SBX1790-51		Q801	8-729-017-06	TRANSISTOR 2SC4793	
IC1200	8-759-250-68	IC TDA7264		Q802	8-729-016-32	TRANSISTOR 2SC4927-01	
IC1201	8-759-502-21	IC TDA2822M		Q803	8-729-119-80	TRANSISTOR 2SC2688-LK	
		< JACK SOCKET >		Q805	8-729-900-89	TRANSISTOR DTC144ES	
J900	1-764-606-11	JACK		Q900	8-729-119-78	TRANSISTOR 2SC2785-HFE	
		< COIL >		Q1200	8-729-119-78	TRANSISTOR 2SC2785-HFE	
L502	1-412-519-11	INDUCTOR 3.3UH		Q1201	8-729-900-74	TRANSISTOR DTC143TS	
L503	1-412-519-11	INDUCTOR 3.3UH		Q1202	8-729-900-80	TRANSISTOR DTC114ES	
L609	1-412-533-21	INDUCTOR 47UH		Q1203	8-729-900-74	TRANSISTOR DTC143TS	
L611	1-412-527-11	INDUCTOR 15UH		Q1204	8-729-900-74	TRANSISTOR DTC143TS	
L612	1-412-522-41	INDUCTOR 5.6UH				< RESISTOR >	
L613	1-412-522-41	INDUCTOR 5.6UH		R500	1-215-457-00	METAL 33K 1% 1/4W	
				R502	1-249-421-11	CARBON 2.2K 5% 1/4W	
				R503	1-249-429-11	CARBON 10K 5% 1/4W	
				R504	1-215-455-00	METAL 27K 1% 1/4W	
				R505	1-249-382-11	CARBON 1.2 5% 1/4W F	
				R506	1-215-439-00	METAL 5.6K 1% 1/4W	
				R507	1-215-888-00	METAL OXIDE 220 5% 2W F	
				R508	1-216-371-00	METAL OXIDE 1.5 5% 2W F	
				R509	1-249-443-11	CARBON 0.47 5% 1/4W F	
				R510	1-249-443-11	CARBON 0.47 5% 1/4W F	
				R520	1-215-457-00	METAL 33K 1% 1/4W	

Les composants identifiés par une trame et une marque  sont critiques pour la sécurité. Ne les remplacer que par une pièce portant le numéro spécifié.

The components identified by shading and marked  are critical for safety. Replace only with the part number specified.

D

REF.NO.	PART NO.	DESCRIPTION	REMARK	REF.NO.	PART NO.	DESCRIPTION	REMARK
R521	1-215-455-00	METAL	27K 1% 1/4W	R818	1-215-882-00	METAL OXIDE	22 5% 2W F
R522	1-247-863-91	CARBON	22K 5% 1/4W	R819	1-216-345-11	METAL OXIDE	0.47 5% 1W F
R523	1-247-863-91	CARBON	22K 5% 1/4W	R820	1-249-403-11	CARBON	68 5% 1/4W
R524	1-249-425-11	CARBON	4.7K 5% 1/4W	R821	1-215-909-11	METAL OXIDE	47 5% 3W F
R525	1-249-425-11	CARBON	4.7K 5% 1/4W	R822	1-215-868-00	METAL OXIDE	680 5% 1W F
R526	1-249-421-11	CARBON	2.2K 5% 1/4W	R824	1-249-420-11	CARBON	1.8K 5% 1/4W
R527	1-215-437-00	METAL	4.7K 1% 1/4W	R826	1-247-752-11	CARBON	1K 5% 1/2W
R600	1-216-490-11	METAL OXIDE	39K 5% 3W F	R827	1-249-425-11	CARBON	4.7K 5% 1/4W
R601	1-249-417-11	CARBON	1K 5% 1/4W	R828	1-249-430-11	CARBON	12K 5% 1/4W
R602	1-215-473-00	FILM	150K 15 1/4W	R829	1-249-493-11	CARBON	56K 5% 1/2W
R603	1-215-898-11	METAL OXIDE	10K 5% 2W F	R830	1-217-778-11	FUSIBLE	1K 5% 1W F
R604	1-249-420-11	CARBON	1.8K 5% 1/4W	R833	1-247-887-00	CARBON	220K 5% 1/4W
R605	1-216-362-11	METAL OXIDE	0.27 5% 2W F	R835	1-216-471-11	METAL OXIDE	27 5% 3W F
R607	1-216-421-11	METAL OXIDE	12 5% 1W F	R836	1-249-439-11	CARBON	68K 5% 1/4W
R608	1-216-365-00	METAL OXIDE	0.47 5% 2W F	R837	1-249-427-11	CARBON	6.8K 5% 1/4W
R610	1-215-421-00	METAL	1K 1% 1/4W	R840	1-247-807-31	CARBON	100 5% 1/4W
R611	1-216-354-11	METAL OXIDE	2.7 5% 1W F	R841	1-249-418-11	CARBON	1.2K 5% 1/4W
R612	1-249-428-11	CARBON	8.2K 5% 1/4W	R842	1-249-441-11	CARBON	100K 5% 1/4W F
R613	1-249-417-11	CARBON	1K 5% 1/4W	R843	1-249-441-11	CARBON	100K 5% 1/4W F
R614	1-215-877-11	METAL OXIDE	22K 5% 1W F	R846	1-247-885-91	CARBON	180K 5% 1/4W
R615	1-249-435-11	CARBON	33K 5% 1/4W	R847	1-247-895-91	CARBON	470K 5% 1/4W
R616	1-215-471-00	METAL	120K 1% 1/4W	R848	1-249-863-91	CARBON	22K 5% 1/4W
R617	1-215-901-00	METAL OXIDE	33K 5% 2W F	R849	1-249-429-11	CARBON	10K 5% 1/4W
R618	1-247-863-91	CARBON	22K 5% 1/4W	R850	1-249-425-11	CARBON	4.7K 5% 1/4W
R619	1-216-425-11	METAL OXIDE	56 5% 1W F	R851	1-215-898-11	METAL OXIDE	10K 5% 2W F
R620	1-260-131-11	CARBON	470K 5% 1/2W	R852	1-249-432-11	CARBON	18K 5% 1/4W
R621	1-216-425-11	METAL OXIDE	56 5% 1W F	R900	1-247-815-91	CARBON	220 5% 1/4W
R622	1-249-437-11	CARBON	47K 5% 1/4W	R901	1-247-734-11	CARBON	39 5% 1/2W
R623	1-249-429-11	CARBON	10K 5% 1/4W	R902	1-247-734-11	CARBON	39 5% 1/2W
R624	1-249-393-11	CARBON	10 5% 1/4W F	R904	1-249-389-11	CARBON	4.7 5% 1/4W F
R625	1-249-434-11	CARBON	27K 5% 1/4W	R905	1-247-804-11	CARBON	75 5% 1/4W
R626	1-249-430-11	CARBON	12K 5% 1/4W			(KV-29C1A/29C1B/29C1D/29C1E/29C1K/29C1R)	
R627	1-216-347-11	METAL OXIDE	0.68 5% 1W F	R906	1-247-804-11	CARBON	75 5% 1/4W
R628	1-249-415-11	CARBON	680 5% 1/4W F			(KV-29C1A/29C1B/29C1D/29C1E/29C1K/29C1R)	
R629	1-244-945-91	CARBON	1M 5% 1/2W	R907	1-247-804-11	CARBON	75 5% 1/4W
R630	1-218-265-21	METAL	8.2M 5% 1W			(KV-29C1A/29C1B/29C1D/29C1E/29C1K/29C1R)	
R631	1-205-949-11	WIREWOUND	1.8 5% 10W	R908	1-249-401-11	CARBON	47 5% 1/4W
R632	1-247-807-31	CARBON	100 5% 1/4W	R909	1-249-429-11	CARBON	10K 5% 1/4W
R633	1-247-807-31	CARBON	100 5% 1/4W	R910	1-249-422-11	CARBON	2.7K 5% 1/4W
R634	1-249-397-11	CARBON	22 5% 1/4W F	R911	1-249-426-11	CARBON	5.6K 5% 1/4W
R635	1-249-437-11	CARBON	47K 5% 1/4W	R912	1-249-429-11	CARBON	10K 5% 1/4W
R636	1-249-417-11	CARBON	1K 5% 1/4W	R913	1-247-863-91	CARBON	22K 5% 1/4W
R637	1-247-815-91	CARBON	220 5% 1/4W	R914	1-249-437-11	CARBON	47K 5% 1/4W
R638	1-247-863-91	CARBON	22K 5% 1/4W	R919	1-249-437-11	CARBON	47K 5% 1/4W
R639	1-215-439-00	METAL	5.6K 1% 1/4W			(KV-29C1A/29C1B/29C1D/29C1E/29C1K/29C1R)	
R642	1-205-949-11	WIREWOUND	1.8 5% 10W	R921	1-249-437-11	CARBON	47K 5% 1/4W
R645	1-249-422-11	CARBON	2.7K 5% 1/4W	R922	1-247-807-31	CARBON	100 5% 1/4W
R646	1-249-377-11	CARBON	0.47 5% 1/4W F	R923	1-249-412-11	CARBON	390 5% 1/4W
R647	1-202-933-61	FUSIBLE	0.1 10% 1/2W F			(KV-29C1A/29C1B/29C1D/29C1E/29C1K/29C1R)	
R649	1-249-426-11	CARBON	5.6K 5% 1/4W F	R1200	1-249-425-11	CARBON	4.7K 5% 1/4W
R800	1-249-421-11	CARBON	2.2K 5% 1/4W	R1201	1-249-434-11	CARBON	27K 5% 1/4W
R802	1-249-431-11	CARBON	22K 5% 1/4W	R1202	1-249-393-11	CARBON	10 5% 1/4W F
R803	1-249-424-11	CARBON	3.9K 5% 1/4W	R1203	1-249-421-11	CARBON	2.2K 5% 1/4W
R805	1-249-429-11	CARBON	10K 5% 1/4W	R1204	1-249-421-11	CARBON	2.2K 5% 1/4W
R809	1-247-891-00	CARBON	330K 5% 1/4W	R1205	1-249-428-11	CARBON	8.2K 5% 1/4W
R812	1-249-421-11	CARBON	2.2K 5% 1/4W				
R813	1-215-867-00	METAL OXIDE	470 5% 1W F				
R814	1-249-411-11	CARBON	330 5% 1/4W				
R816	1-215-917-11	METAL OXIDE	1K 5% 3W F				
R817	1-216-481-11	METAL OXIDE	1.2K 5% 3W F				

Les composants identifiés par une trame et une marque  sont critiques pour la sécurité. Ne les remplacer que par une pièce portant le numéro spécifié.

The components identified by shading and marked  are critical for safety. Replace only with the part number specified.











REF.NO.	PART NO.	DESCRIPTION	REMARK	REF.NO.	PART NO.	DESCRIPTION	REMARK
R1206	1-249-428-11	CARBON	8.2K 5% 1/4W			< DIODE >	
R1208	1-212-849-00	FUSIBLE	4.7 5% 1/4W F				
R1209	1-212-849-00	FUSIBLE	4.7 5% 1/4W F	D1701	8-719-991-33	DIODE 1SS133T-77	
R1211	1-249-424-11	CARBON	3.9K 5% 1/4W	D1702	8-719-110-88	DIODE RD39ES-B2	
				D1703	8-719-110-88	DIODE RD39ES-B2	
R1212	1-249-424-11	CARBON	3.9K 5% 1/4W			< COIL >	
R1213	1-249-421-11	CARBON	2.2K 5% 1/4W	L1701	1-408-409-00	INDUCTOR 10UH	
R1216	1-249-413-11	CARBON	470 5% 1/4W	L1702	1-408-403-00	INDUCTOR 3.3UH	
R1217	1-249-425-11	CARBON	4.7K 5% 1/4W	L1703	1-408-409-00	INDUCTOR 10UH	
				L1704	1-408-418-00	INDUCTOR 56UH	
				L1705	1-408-418-00	INDUCTOR 56UH	
< RELAY >							
RY600	1-755-018-11	RELAY				< TRANSISTOR >	
< SWITCH >							
S601	1-571-433-21	SWITCH, PUSH (AC POWER)		Q1701	8-729-119-78	TRANSISTOR 2SC2785-HFE	
S900	1-692-979-11	SWITCH, TACTILE		Q1702	8-729-119-78	TRANSISTOR 2SC2785-HFE	
S901	1-692-979-11	SWITCH, TACTILE		Q1703	8-729-017-05	TRANSISTOR 2SA1837	
S902	1-692-979-11	SWITCH, TACTILE		Q1704	8-729-119-78	TRANSISTOR 2SC2785-HFE	
				Q1706	8-729-017-06	TRANSISTOR 2SC4793	
< SPARK GAP >							
SG801	1-519-422-11	GAP, SPARK		Q1708	8-729-119-78	TRANSISTOR 2SC2785-HFE	
				Q1709	8-729-119-78	TRANSISTOR 2SC2785-HFE	
				Q1840	8-729-119-78	TRANSISTOR 2SC2785-HFE	
< TRANSFORMER >							
LF600	1-421-776-21	LFT				< RESISTOR >	
LF601	1-421-776-21	LFT		R1701	1-249-417-11	CARBON 1K 5% 1/4W	
T601	1-429-605-11	SRT		R1702	1-249-417-11	CARBON 1K 5% 1/4W	
T800	1-424-545-11	TRANSFORMER, FERRITE (PMT)		R1703	1-249-421-11	CARBON 2.2K 5% 1/4W	
T803	1-453-169-11	TRANSFORMER ASSY, FLYBACK (UX-1604A2)		R1704	1-249-415-11	CARBON 680 5% 1/4W	
T804	1-437-090-31	HDT		R1705	1-247-815-91	CARBON 220 5% 1/4W	
< THERMISTOR >							
THP600	1-809-827-11	THERMISTOR, POSITIVE		R1706	1-247-815-91	CARBON 220 5% 1/4W	

*A-1644-070-A	VM BOARD, COMPLETE			R1708	1-249-412-11	CARBON 390 5% 1/4W	
*4-368-683-11	SPRING, TRANSISTOR			R1712	1-260-311-11	CARBON 39 5% 1/2W	
				R1713	1-249-384-11	CARBON 1.8 5% 1/4W F	
				R1714	1-249-414-11	CARBON 560 5% 1/4W F	
< CAPACITOR >							
C1701	1-126-933-11	ELECT	100MF 20% 16V	R1715	1-249-432-11	CARBON 18K 5% 1/4W	
C1702	1-128-551-11	ELECT	22MF 20% 25V	R1716	1-249-417-11	CARBON 1K 5% 1/4W F	
C1703	1-126-933-11	ELECT	100MF 20% 16V	R1717	1-216-476-11	METAL OXIDE 180 5% 3W F	
C1704	1-137-403-51	FILM	0.47MF 5% 100V	R1718	1-249-432-11	CARBON 18K 5% 1/4W	
C1705	1-107-638-11	ELECT	33MF 20% 160V	R1719	1-249-384-11	CARBON 1.8 5% 1/4W F	
C1706	1-104-999-11	FILM	0.1MF 5% 200V	R1720	1-249-400-11	CARBON 39 5% 1/4W F	
C1707	1-137-397-11	FILM	0.047MF 5% 100V	R1721	1-249-414-11	CARBON 560 5% 1/4W	
C1708	1-137-364-11	FILM	0.001MF 5% 50V	R1722	1-249-401-11	CARBON 47 5% 1/4W	
C1709	1-137-364-11	FILM	0.001MF 5% 50V	R1724	1-249-400-11	CARBON 39 5% 1/4W	
C1710	1-102-074-00	CERAMIC	0.001MF 10% 50V	R1725	1-216-451-11	METAL OXIDE 120 5% 2W F	
C1720	1-107-667-11	ELECT	2.2MF 20% 160V	R1728	1-249-413-11	CARBON 470 5% 1/4W	
C1721	1-137-397-11	FILM	0.047MF 5% 100V	R1729	1-249-413-11	CARBON 470 5% 1/4W	
C1722	1-126-934-11	ELECT	220MF 20% 16V	R1730	1-249-422-11	CARBON 2.7K 5% 1/4W	
C1723	1-161-830-00	CERAMIC	0.0047MF 500V	R1731	1-249-411-11	CARBON 330 5% 1/4W	
C1725	1-128-551-11	ELECT	22MF 20% 25V	*****			
C1726	1-126-934-11	ELECT	220MF 20% 16V				
< CONNECTOR >							
CN1015	*1-568-880-51	PIN, CONNECTOR 5P					
CN1718	1-774-418-11	CONNECTOR, BOARD TO BOARD 8P					

Les composants identifiés par une trame et une marque  sont critiques pour la sécurité. Ne les remplacer que par une pièce portant le numéro spécifié.

The components identified by shading and marked  are critical for safety. Replace only with the part number specified.

REF.NO.	PART NO.	DESCRIPTION	REMARK
MISCELLANEOUS *****			
	 1-406-807-11	COIL, DEGAUSSING	
	1-452-032-00	MAGNET, DISK; 10MM Ø	
	1-452-094-00	MAGNET, ROTATABLE DISK; 15MM Ø	
	 1-453-169-11	TRANSFORMER ASSY, FLYBACK(NX-1604A2)	
	1-504-146-11	SPEAKER (5x11CM)	
	 1-571-433-21	SWITCH, PUSH (AC POWER)	
	1-693-338-11	TUNER/VIF (AEP) (KV-29C1A/29C1D/29C1D 1/29C1E/29C1K/ 29C1R)	
	1-693-340-11	TUNER/VIF (FR) (KV-29C1B)	
	 1-751-680-11	CORD, POWER (WITH NOISE FILTER) 2.5A/250V (KV-29C1A/29C1D/29C1D1)	
	 1-690-270-21	CORD, POWER (WITH CONNECTOR) 2.5A/250V (KV-29C1B/29C1E/29C1K/29C1R)	
	 8-451-467-11	DEFLECTION YOKE (Y29GXA2B)	
	 8-453-005-11	NECK ASSY, PICTURE TUBE (NA-297-M)	
V901	 8-733-856-05	PICTURE TUBE (SD-269) (M68LCT60X)	
	 8-733-856-71	ITC	

ACCESSORIES AND PACKING MATERIALS

4-203-366-41	MANUAL, INSTRUCTION (KV-29C1A) (ITALIAN)
4-203-366-51	MANUAL, INSTRUCTION (KV-29C1B) (FRENCH/GERMAN/ITALIAN/DUTCH)
4-203-366-11	MANUAL, INSTRUCTION (KV-29C1D) (DUTCH/GREEK/ENGLISH/GERMAN/TURKISH)
4-203-372-11	MANUAL, INSTRUCTION (KV-29C1D) (ENGLISH/DUTCH)
4-203-366-71	MANUAL, INSTRUCTION (KV-29C1E) (SPANISH)
4-203-366-81	MANUAL, INSTRUCTION (KV-29C1E) (PORTUGUESE/FINNISH/DANISH/NORWEGIAN/ SWEDISH)
4-203-366-91	MANUAL, INSTRUCTION (KV-29C1K/29C1R) (CZECH/ENGLISH/POLISH/BULGARIAN/ RUSSIAN)
*4-203-331-01	INDIVIDUAL CARTON
*4-203-334-01	CUSHION (LOWER) (ASSY)
*4-203-335-01	CUSHION (UPPER) (ASSY)
*4-395-957-01	BAG, PROTECTION

REMOTE COMMANDER

1-473-693-11	COMMANDER, STANDARD TYPE (RM-839)
--------------	-----------------------------------



Free service manuals
Gratis schema's
Digitized by
www.freesevicemanuals.info

KV-29C1

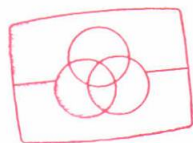

Free service manuals
Gratis schema's
Digitized by

www.freeservicemanuals.info