

# PS-T1



Canadian Model  
US Model  
AEP Model  
UK Model  
E Model



Free service manuals  
Gratis schema's

Digitized by

[www.freeservicemanuals.info](http://www.freeservicemanuals.info)

## STEREO TURNTABLE SYSTEM

### SPECIFICATIONS

#### GENERAL

**Power Requirements:** 120, 220 V ac (E, AEP model serial No. 511501 and later)  
110, 120, 220, 240 V ac adjustable, 50/60 Hz (AEP model up to serial No. 511500)  
240 V ac, 50 Hz (UK model)  
120 V ac, 60 Hz (US, Canadian model)

**Power Consumption:** 8W (AEP, UK, E model)  
6W (US, Canadian model)

**Dimensions:** Approx. 445 (w) x 140 (h) x 375 (d) mm  
17½ (w) x 5½ (h) x 14¾ (d) inches  
including projecting parts and controls

**Weight:** Approx. 5 kg, 11 lb (net)  
6 kg, 13 lb 4 oz (with shipping carton)

#### TURNTABLE

**Platter:** 31.3 cm, 12¾ inches, aluminum-alloy diecast

**Motor:** DC servo-controlled motor (brushless and slotless)

**Drive System:** Direct drive

**Speeds:** 33⅓, 45 rpm

**Pitch Control Range:** ± 4 %  
**Wow and Flutter:** 0.04 % (WRMS)  
± 0.065 % (DIN)  
**S/N Ratio:** 68 dB (DIN-B)  
**Automatic System:** Arm return, reject

#### TO NEARM

**Type:** Statically balanced, universal  
**Pivot-to-Stylus Length:** 216.5 mm, 8½ inches  
**Overall Arm Length:** 300 mm, 11⅞ inches  
**Overhang:** 16.5 mm, 21/32 inches  
**Tracking Error:** +3°, -1°  
**Tracking-Force Adjustment Range:** 0-3 g  
**Shell Weight:** 7.5 g  
**Cartridge Weight Range:** 4-10 g

#### ATTENTION AU COMPOSANT AYANT RAPPORT À LA SÉCURITÉ !

LES COMPOSANTS IDENTIFIÉS PAR UN TRAMÉ ET UNE MARQUE ⚠ SUR LES DIAGRAMMES SCHEMATIQUES, LES VUES EXPLOSÉES ET LA LISTE DES PIÈCES SONT CRITIQUES POUR LA SÉCURITÉ DE FONCTIONNEMENT. NE REMPLACER CES COMPOSANTS QUE PAR DES PIÈCES SONY DONT LES NUMÉROS SONT DONNÉS DANS CE MANUEL OU DES SUPPLÉMENTS PUBLIÉS PAR SONY.

#### SAFETY-RELATED COMPONENT WARNING!!

COMPONENTS IDENTIFIED BY SHADING AND ⚠ MARK ON THE SCHEMATIC DIAGRAMS, EXPLODED VIEWS AND IN THE PARTS LIST ARE CRITICAL TO SAFE OPERATION. REPLACE THESE COMPONENTS WITH SONY PARTS WHOSE PART NUMBERS APPEAR AS SHOWN IN THIS MANUAL OR IN SUPPLEMENTS PUBLISHED BY SONY.



# SECTION 1 OUTLINE

## General Description

Motor Servo System is explained in Block Diagram Fig. 1-1.

Apply the voltage  $V_i$  to the motor coil to rotate at a given speed  $\omega$ , soon the motor reaches the speed  $\omega$ .

Supposedly, any changes occur in the rotational speed, a detector reads the amount of the error and the feedback circuit produces the voltage  $V_f$  required to correct the speed, returning  $V_f$  to the input.

Servo System works to keep the speed constant by adding or subtracting a fraction  $V_f$  of the output to the input  $V_i$ .

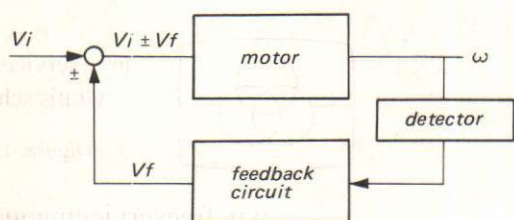

Fig. 1-1

The servo motor employs the frequency generator (FG) as a detector and the feedback circuit as shown in Fig. 1-2.

The signal voltage generated in FG is fed to the limiter amplifier to eliminate the voltage fluctuation, and in the next stage of the frequency discriminator the variation of the frequency is converted into the voltage proportioned to the rotational speed.

This voltage is rectified, amplified by DC amplifier and supplied to the motor.

The reference standard frequencies detected by the multi-gap head (MGH) are 284 Hz at 33 rpm and 384 Hz at 45 rpm.

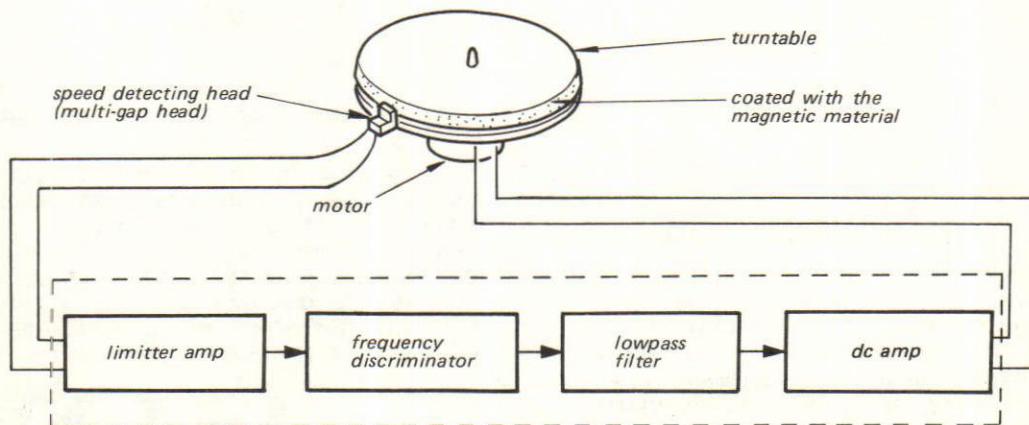

Fig. 1-2

## Circuit Description (See Fig. 1-5)

### Limiter IC1-1

When the turntable rotates, the speed detecting head (MGH) generates the voltage. Its waveform is sinusoidal.

The voltage is applied to IC1-1 and the voltage fluctuation is eliminated. C1 serves as an interference eliminator.

### Q1

Q1 amplifies the output signal from IC1-1 and converts it into a square wave by clipping.

### Differential Circuit C2, R4

The differentiation of the square wave produces trigger pulses in the C2, R4 differential circuit.

This pulse triggers the sawtooth wave generator Q2.

### Sawtooth Wave Generator Circuit Q2, C3

While Q2 is turned off, C3 is charged through R5. When the positive trigger pulse is applied to the base of Q2, Q2 turns on and then C3 discharges instantly through Q2.

After discharging, C3 is recharged, resulting in the Q3 base forming a sawtooth wave signal.

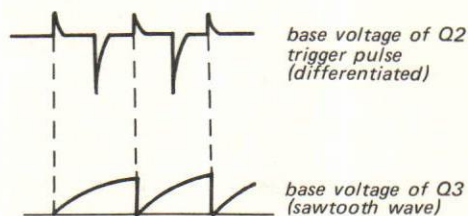

Fig. 1-3

**Comparator Q3, Q4**

The sawtooth wave signal is applied to the comparator circuit formed by Q3 and Q4.

Since the base of Q4 is biased by the bleeder resistor RV2, R9, RV1 (RV3, R10, RV1) and R8, the emitter voltage of Q4 and Q3 are held to the reference voltage.

Q3 will turn on when its base voltage (sawtooth wave) exceeds the total voltage (emitter voltage plus  $V_{BE}$ ).

Then, a negative pulse will appear on the collector of Q3. Consequently, if the rotational speed slows down, the frequency of the sawtooth wave will be low.

Therefore, the output negative pulse width widens, because the period of the time, Q3 turns on, becomes short.

**Phase Converter Q5**

Q5 serves as a phase converter which feeds the positive pulse signal on to the next stage.

**Integrator (Lowpass Filter)**

The lowpass filter (being composed of R12, R13, R14, C4, C5 and C6) serves as an integrator which converts the pulse signal into dc voltage in proportion to the pulse width.

**IC1-2**

IC1-2 is also the lowpass filter and amplifies dc voltage.

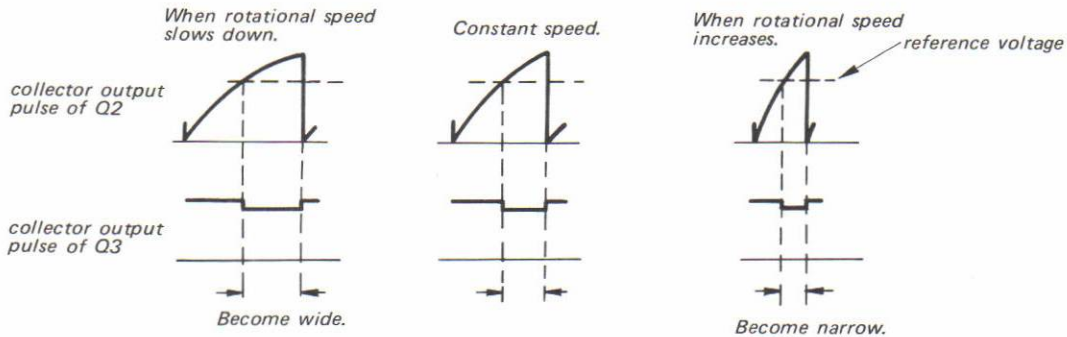

Fig. 1-4

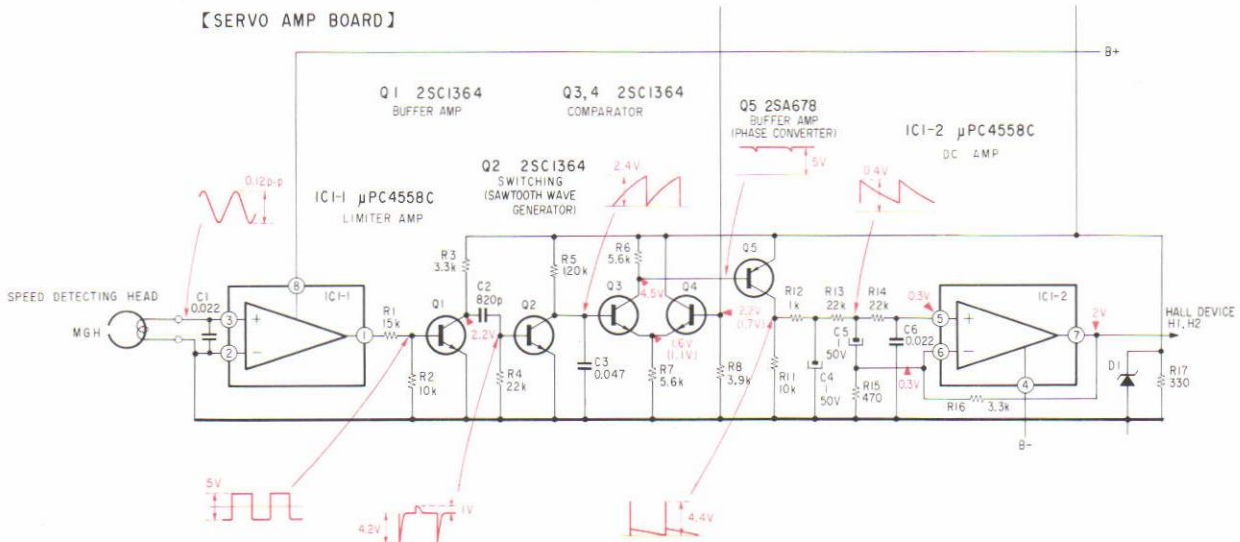

Fig. 1-5



**SPEED Control**

1. The selection of the speed 33/45 rpm can be done by turning the switch S2 which selects the value of the bleeder resistor biased to the Q4 base.
2. Since the base voltage of Q4 at 33 rpm is adjusted higher than the one at 45 rpm, the emitter voltage of Q4 at 33 rpm is higher than the one at 45 rpm.
3. Now, let turn the switch S2 to the speed 45 rpm when rotating at 33 rpm, the pulse width on the collector of Q3 becomes wide as illustrated in Fig. 1-6.

Therefore, DC voltage obtained through the lowpass filter goes up and the motor builds up a speed.

Finally, the motor reaches the speed of 45 rpm and keeps the constant speed at 45 rpm.

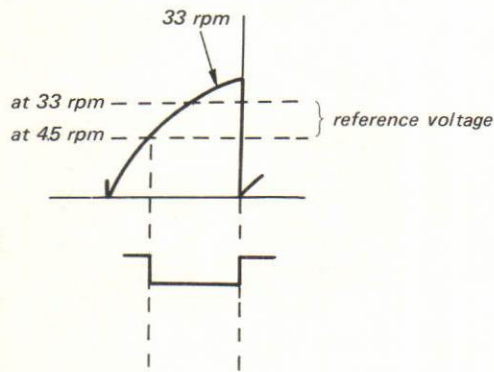

Fig. 1-6

**Servo System**

Any changes in the rotational speed of the motor can be corrected in the servo circuit and the motor speed is kept constant.

The servo system works as follows.

1. When the speed of the motor slows down, the frequency of the signal generated by the speed detecting head (multi-gap head) becomes low and the pulse width obtained from the comparator becomes wide.
2. Consequently, dc voltage through the lowpass filter increases, the motor speeds up and reaches the given speed.

**Hall Motor**

The BSL (brushless and slotless) dc servo motor, comprising two pairs of the coreless coil (stator), a sine wave magnetised ring (rotor) and hall elements, has the following major advantages.

- a. Less fluctuation of the torque.
- b. Very low noise due to the brushless, and its current flow is controlled by the electronic switching.
- c. Stable performance and very long operational life.

**1. Hall Element**

The magnetic field strength is converted into electrical signals by employing the Hall Effect.

Hall Effect: When a metal strip is placed with its plane perpendicular to a magnetic field and an electric current flows longitudinally through the strip, a potential difference is developed across the strip at right angles to the current flow and to the magnetic field.

The potential is proportional to amounts of the current and a strength of the magnetic field.

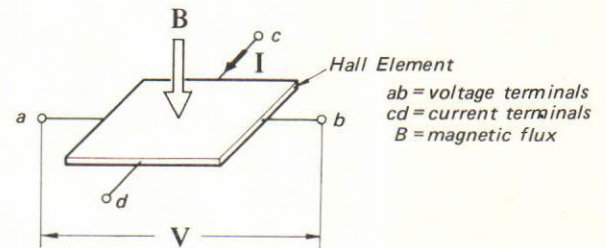

Fig. 1-7

When the N pole approaches.      When the S pole approaches.

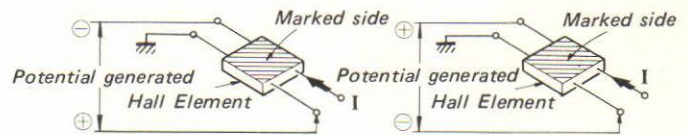

Fig. 1-8



2. Exploded View

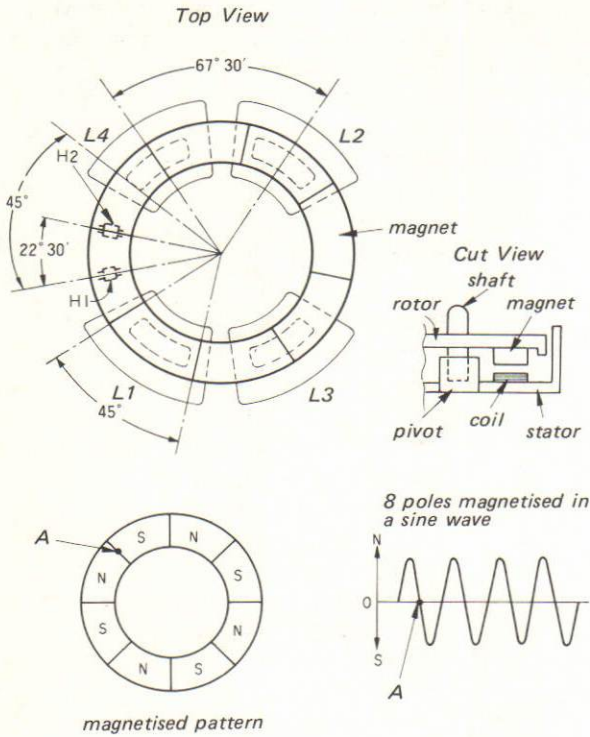

Fig. 1-9

- a. The motor coils L1 and L2 (L3 and L4) are one pair and connected in series.
- b. In order to change the phase of two signals by  $90^\circ$ , Hall elements H1 and H2 are positioned  $22^\circ 30'$  apart.
- c. In order to change the phase of two signals fed to L1 and L3 (L2 and L4) by  $90^\circ$ , coils are positioned at  $67^\circ 30'$  apart.
- d. The center angle of the coil is  $45^\circ$  so that the coil can face the magnets of which 8 poles are positioned every  $45^\circ$  apart.
- e. The angle between the Hall element and the coil is  $45^\circ$  so that the flux peak of the coil comes to the flux peak of the magnet.

3. Generation of Rotational Force

By the Fleming's left-hand rule, the direction of the coil motion is counterclockwise, but the coils are fixed so that the magnet (rotor) rotates clockwise.

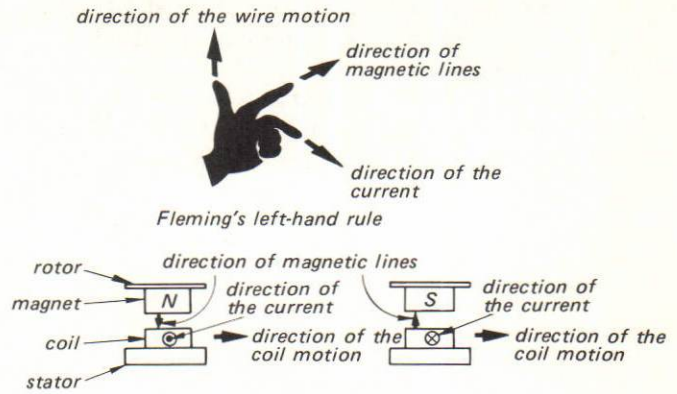

Fig. 1-10

When the Hall element H2 faces the N pole of the magnet, H2 generates voltage. The voltage is amplified by IC2-2 and fed to Q8, which also amplifies and supplies the current in L3 and L4. The coils (L3 and L4) produce the magnetic field that creates the rotational force of the rotor.

When the Hall element H1 faces the N pole, the current flows in L1 and L2, and the rotor rotates in the direction shown by the arrow.

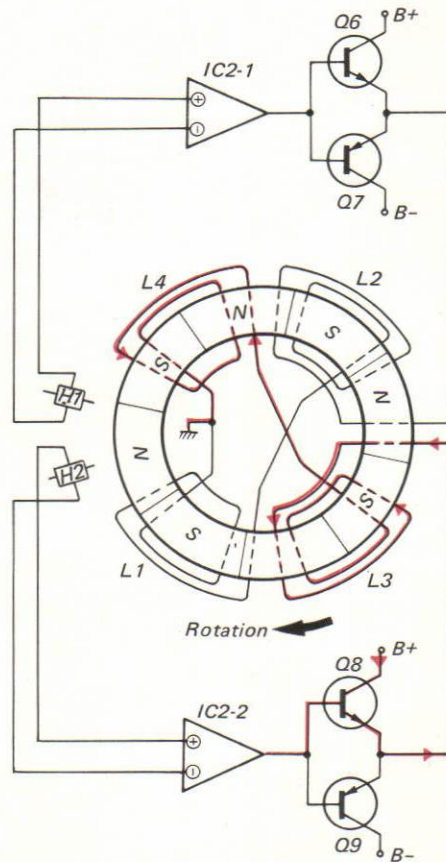

Fig. 1-11

Likewise, when the Hall element H2 faces the S pole, the current flows in L3 and L4. The rotor rotates in the direction shown by the arrow.

When the Hall element H1 faces the S pole, the current flows in L1 and L2, and the rotor is also forced to rotate in the same direction.

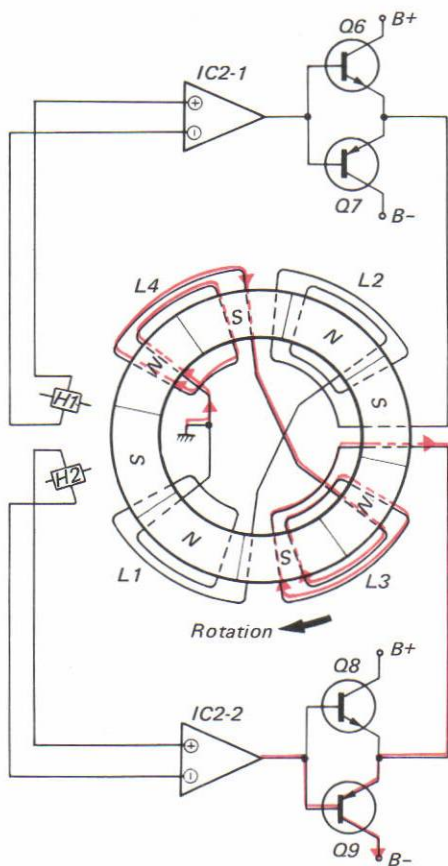

Fig. 1-12

#### 4. Torque

A motor torque is proportional to an intensity of magnetic flux (B) and amounts of current which flows in coils.

Therefore,  $F = B I$

When the rotor which is magnetised in a sine wave pattern rotates, the Hall elements detect the variation of the magnetic flux ( $B_1 = B_0 \sin \omega t$ ).

This controlled current ( $I_1 = I_0 \sin \omega t$ ) is supplied to the one coil.

On other hand, the current, which leads the angle by  $90^\circ$ , is supplied to the other coil.

Thus,  $B_2 = B_0 \sin (\omega t + 90^\circ) = B_0 \cos \omega t$ .

$$I_2 = I_0 \sin (\omega t + 90^\circ) = I_0 \cos \omega t.$$

And, when both torques ( $F_1 = B_1 I_1$ ,  $F_2 = B_2 I_2$ ) are produced simultaneously, their combined torque is constant as shown by the formula.

$$\begin{aligned} F &= F_1 + F_2 \\ &= B_1 I_1 + B_2 I_2 \\ &= B_0 I_0 \sin^2 \omega t + B_0 I_0 \cos^2 \omega t \\ &= B_0 I_0 (\sin^2 \omega t + \cos^2 \omega t) \\ &= B_0 I_0 \text{ constant} \end{aligned}$$



**BLOCK DIAGRAM**

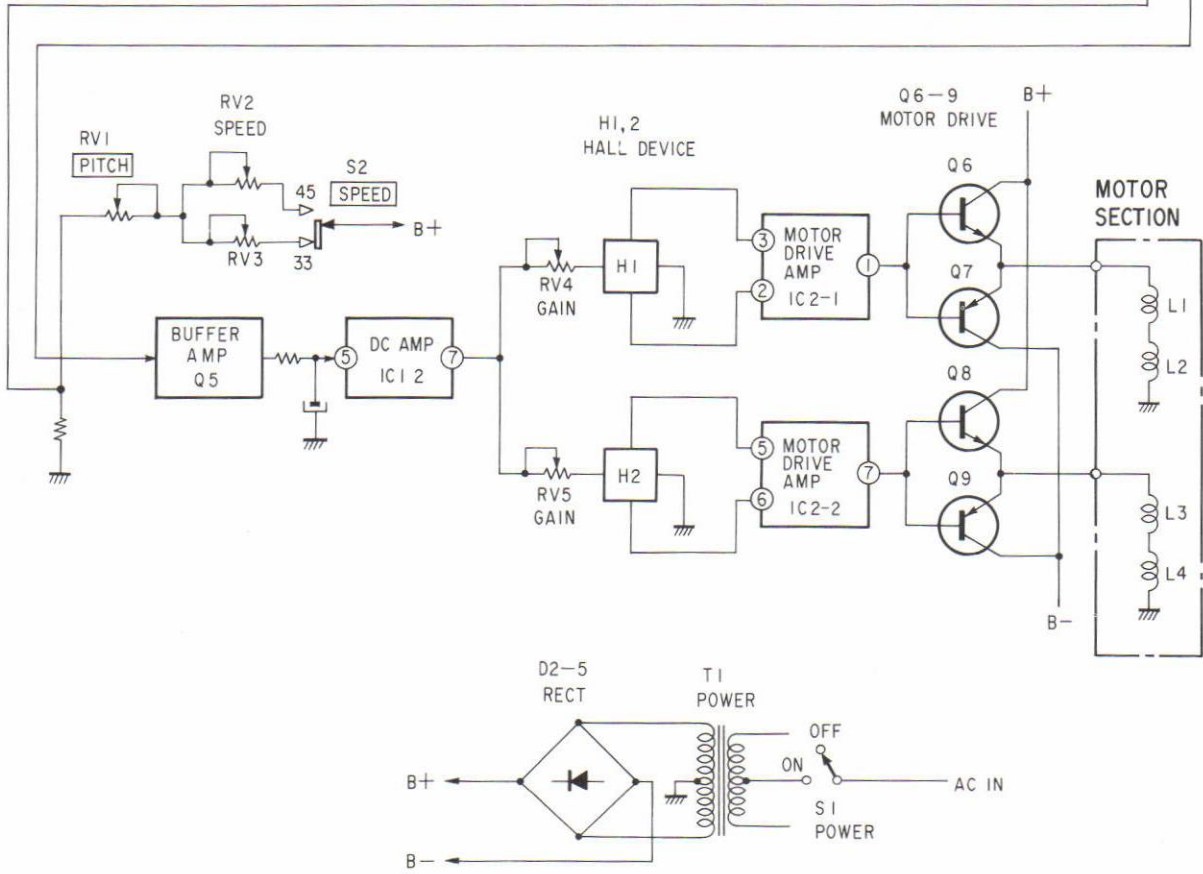
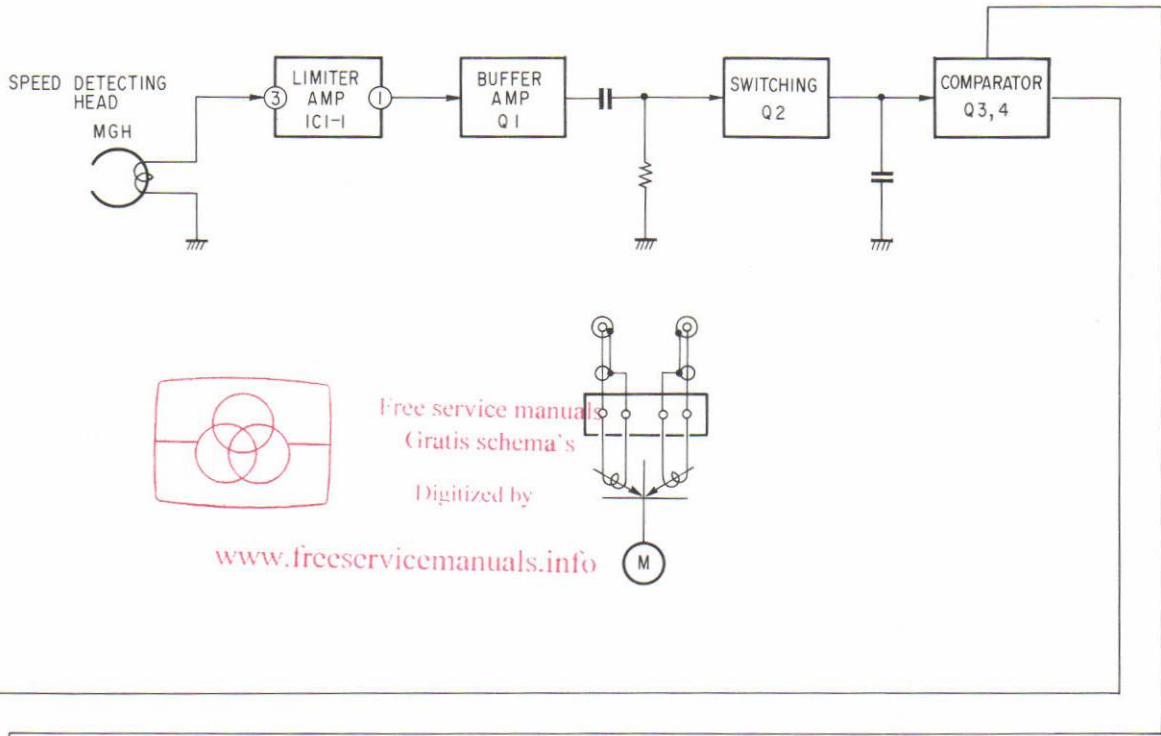

# SECTION 2 DISASSEMBLY

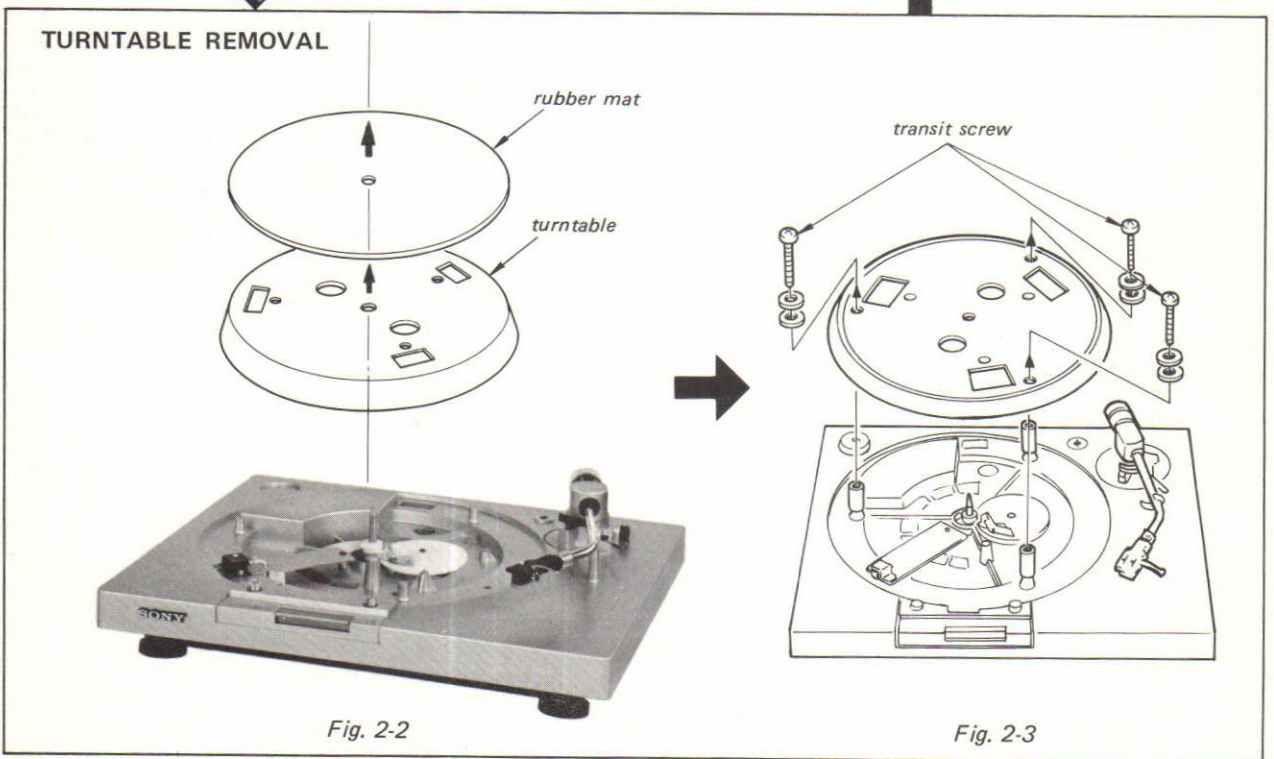
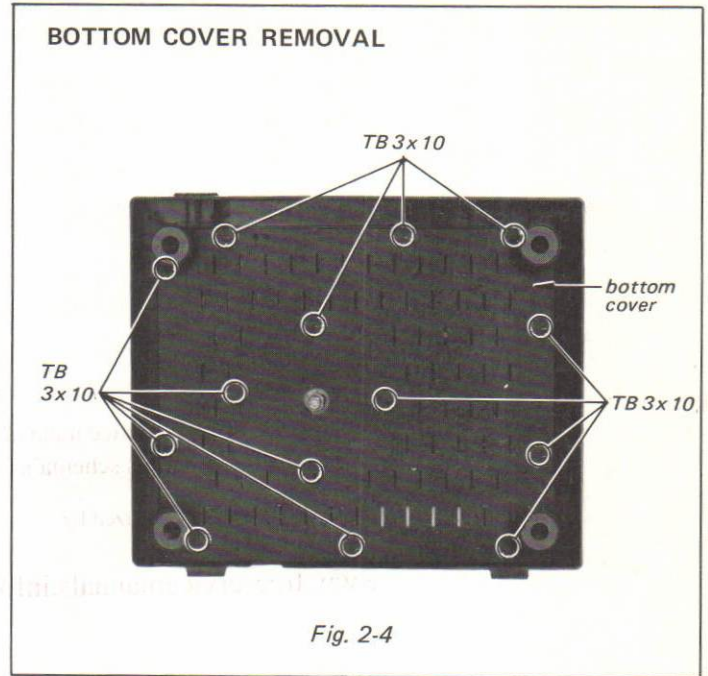
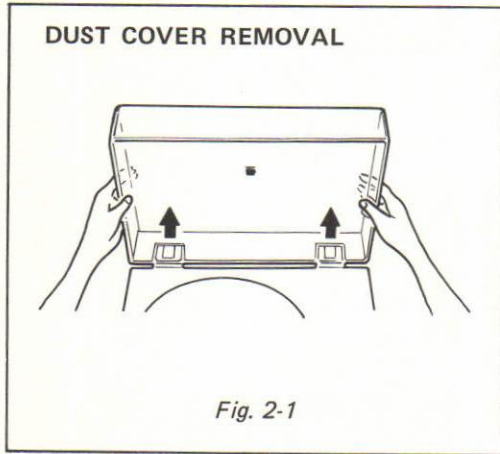



- Follow the disassembly procedure in the numerical order given.

### SERVO AMP BOARD AND MOTOR SECTION REMOVAL

1. Remove four screws and straighten the hooks as shown ① and ② in Fig. 2-5.
2. Confirm that the positions of the center gear and the drive gear are the same as shown in Fig. 2-6. Then, remove the servo amp board and the motor section downward. (Enclosed by the broken line in Fig. 2-5.)

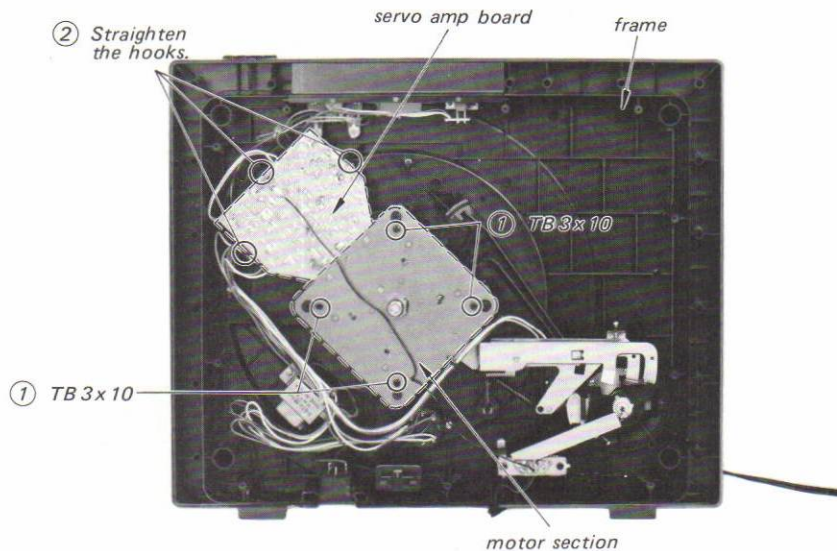

Fig. 2-5

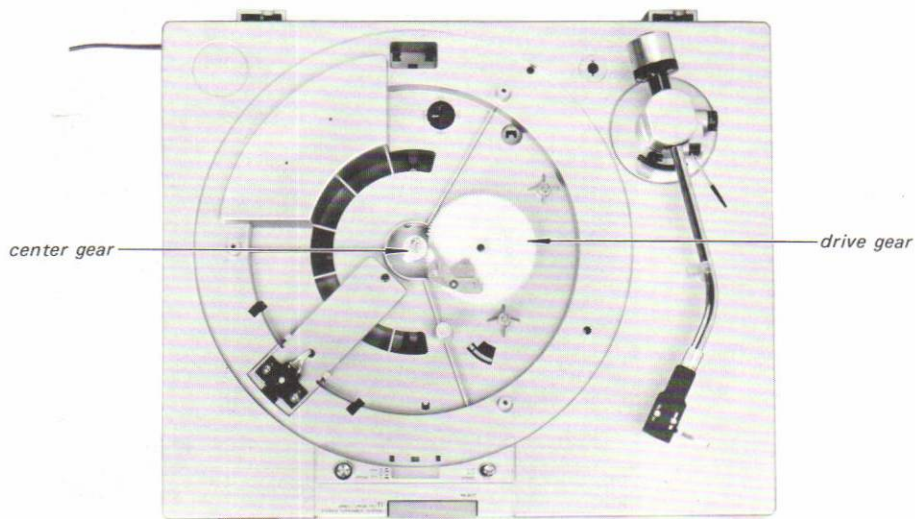
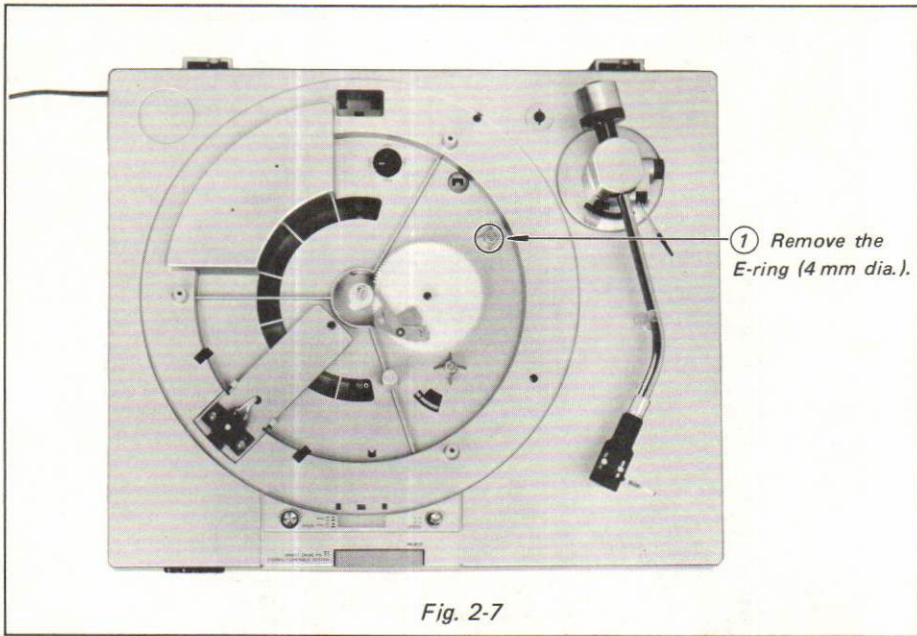
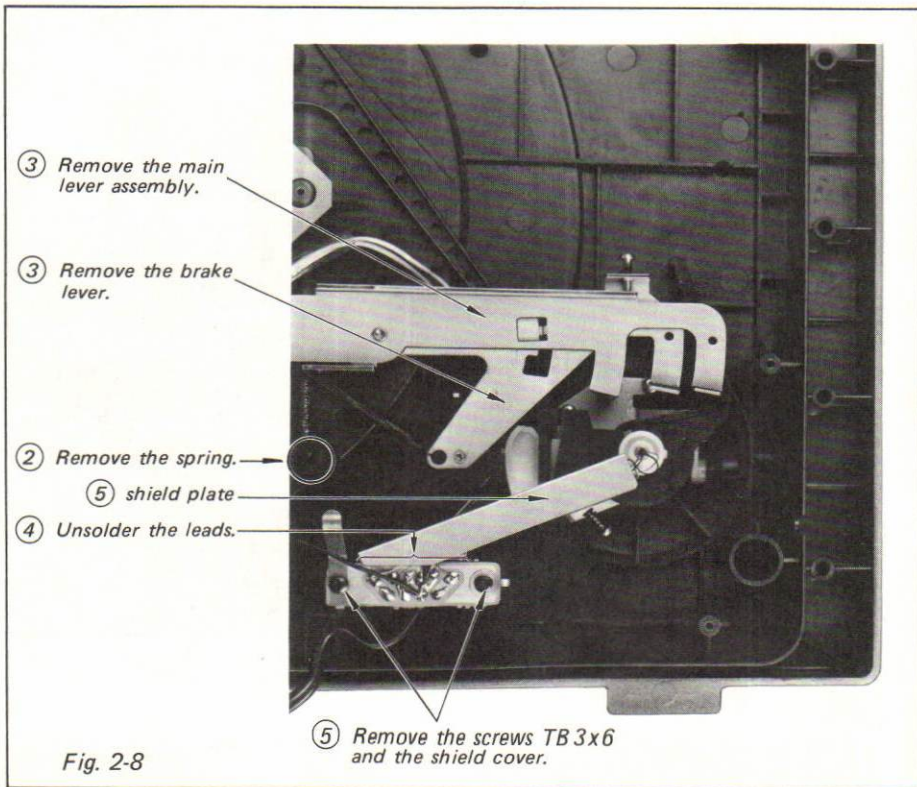

Fig. 2-6

### TONARM REMOVAL



Turn the set upside-down and proceed ②, ③, ④ and ⑤ as shown in Fig. 2-8.





Loosen the screw and pull up the arm lever assembly from the tonearm shaft.

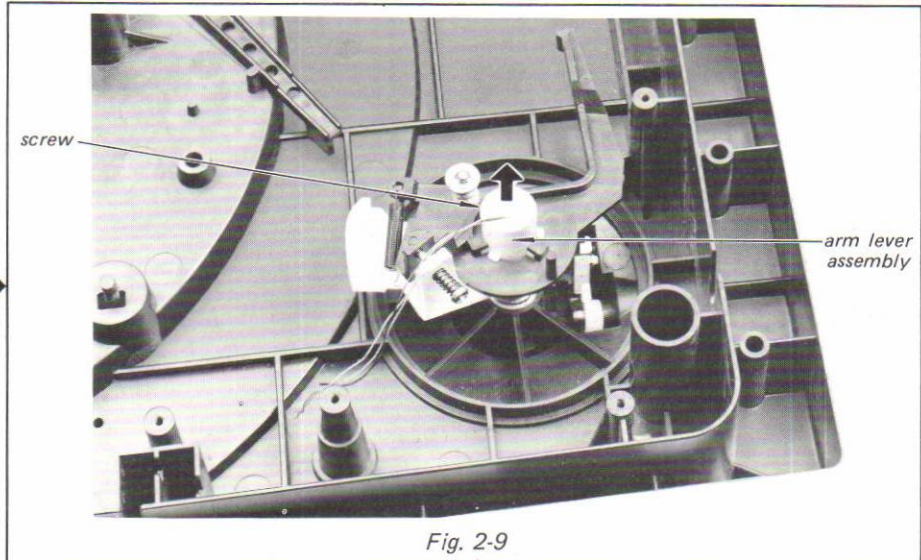

1. Loosen the screw.
2. Hold the tonearm firmly by hand and pull up the thrust nut (D) by turning it counterclockwise.
3. Remove the steel-balls from the arm pivot.
4. Turn the set upside-down again and pull up the tonearm slowly.

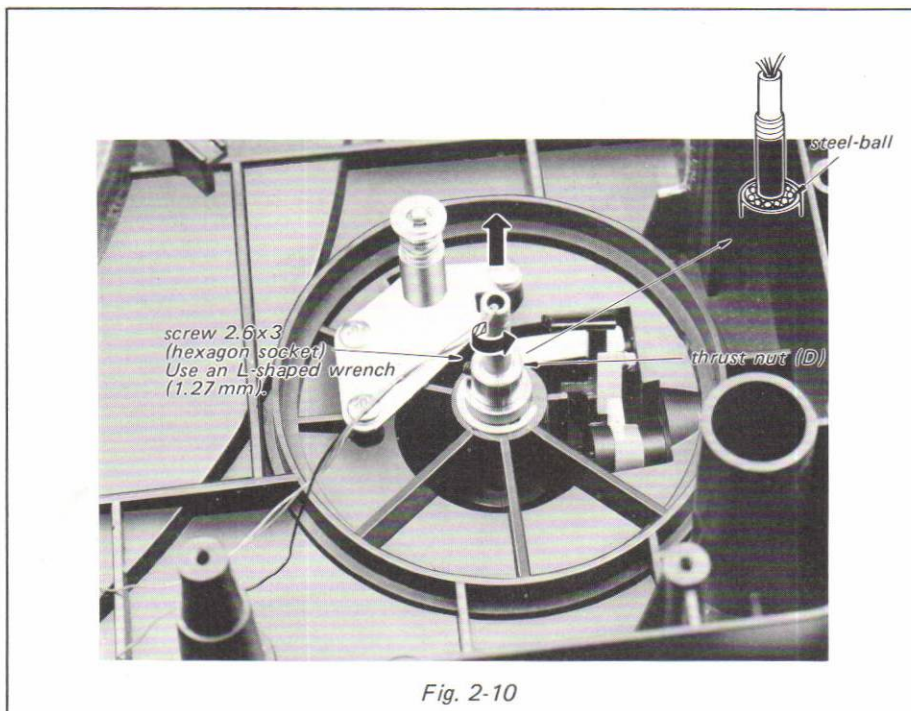

### ARM LIFTER REMOVAL

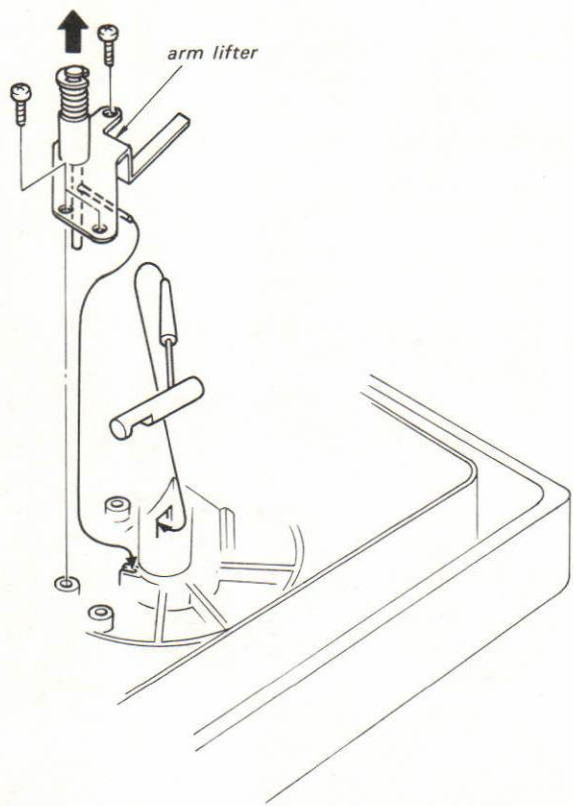
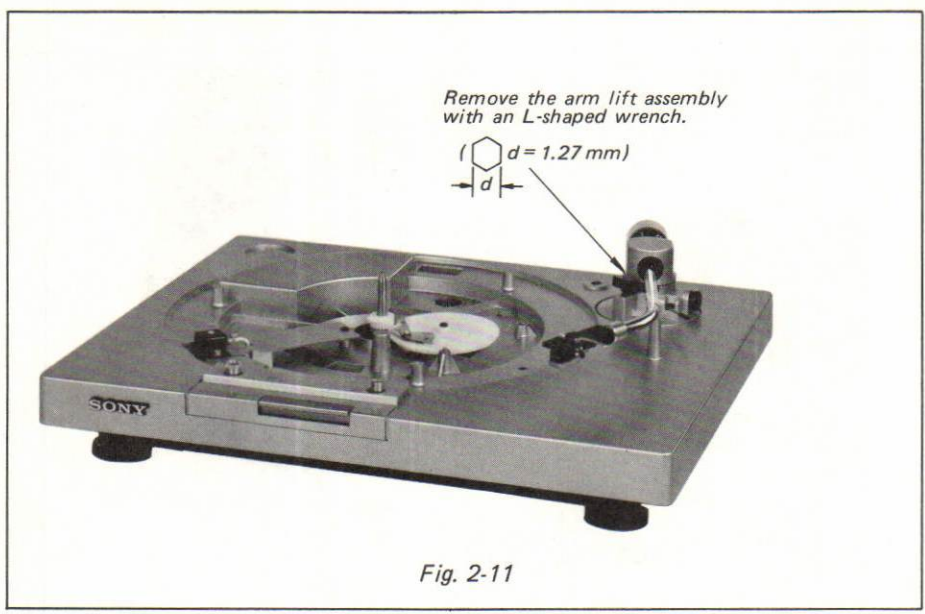

Fig. 2-12



**TOEARM DISASSEMBLY**

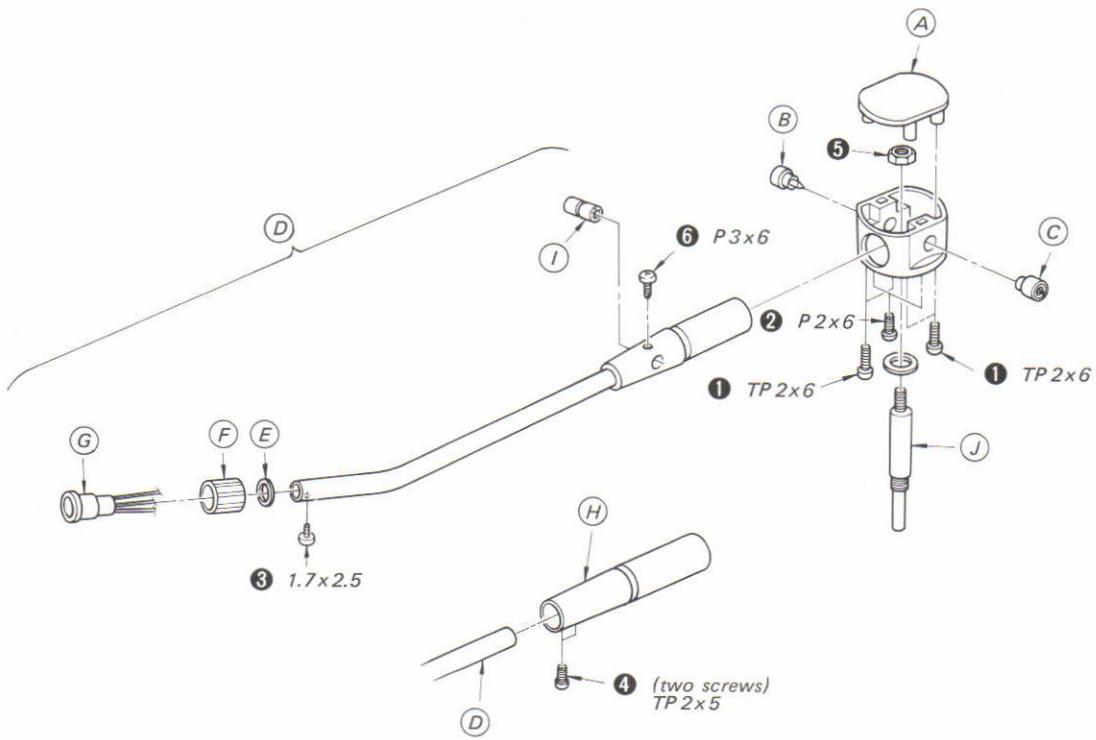
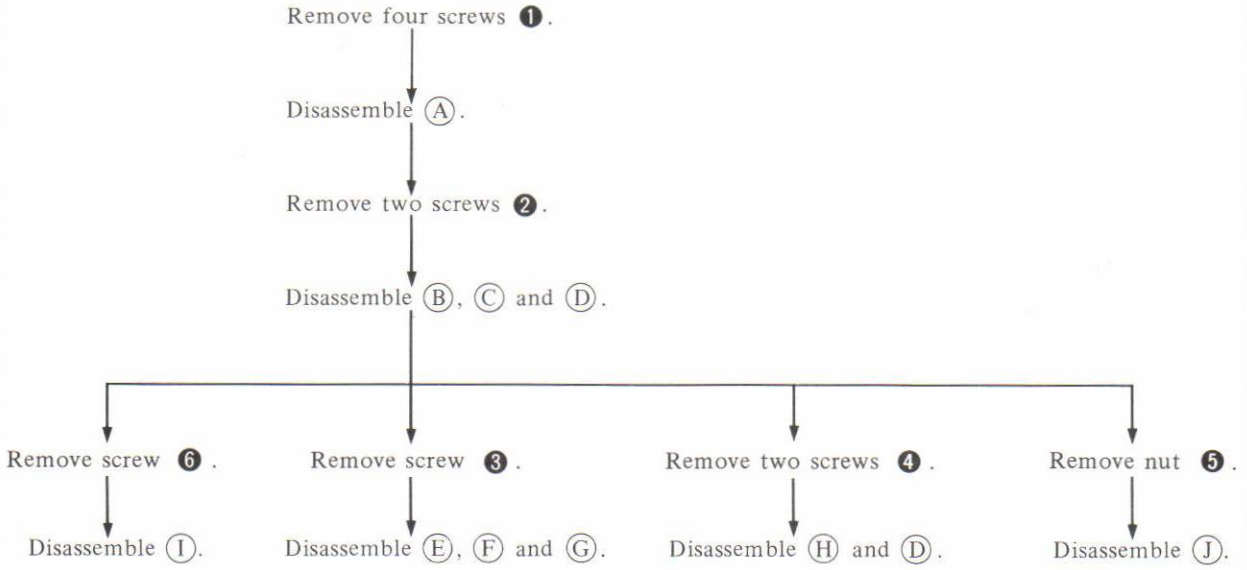

Fig. 2-13

# SECTION 3 ASSEMBLY

## 3-1. TONEARM ASSEMBLY

### 1. Pipe Assembly (1)

1. Thread a wire in (D).
2. Thread the leads of (G) in (F) and (E), and hook the leads by the wire.
3. Insert (G) in (D) by pulling the wire in the direction shown by the arrow, adjust two holes marked \*1, \*2 and tighten the screw (3).

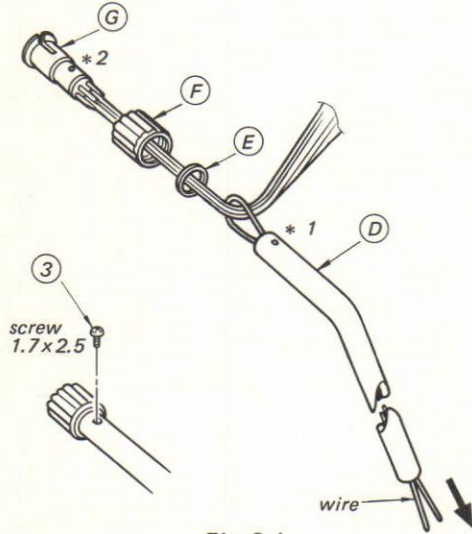

Fig. 3-1

### 2. Pipe Assembly (2)

1. Thread a wire in (H) as shown below.
2. Hook four leads of (K) and (G) together by the wire and pull the leads into (H).
3. Adjust three holes marked \*1, \*2, \*3 to tighten the screws (4).

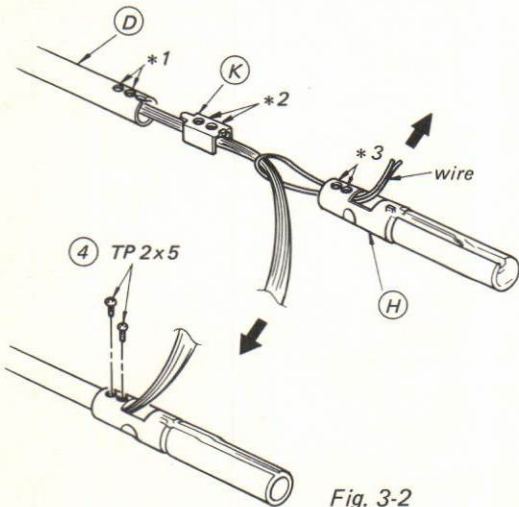

Fig. 3-2

### 4. Setting of Pivot (A) and Pivot (B)

Push the pivot (A) and the pivot (B) into the holes of (L) strongly and tighten the screws (2).

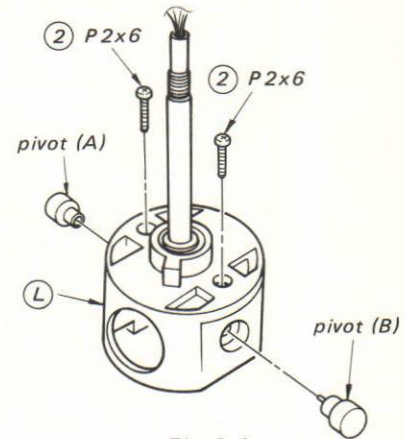

Fig. 3-4

### 3. Installation of Pipe Assembly

1. Thread a wire in (J).
2. Hook five leads of the pipe assembly by the wire.
3. Insert the pipe assembly into (L), while pulling the leads.

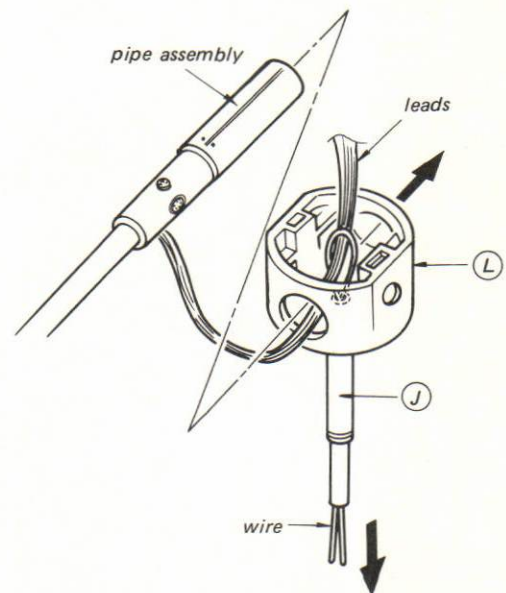

Fig. 3-3



**5. Setting of Pivot Screw and Lock Nut (A)**

1. Adjust the positions of the pivot (A) and the pivot bearing of the center boss.
2. Tighten the screw ① and the nut ② temporarily.

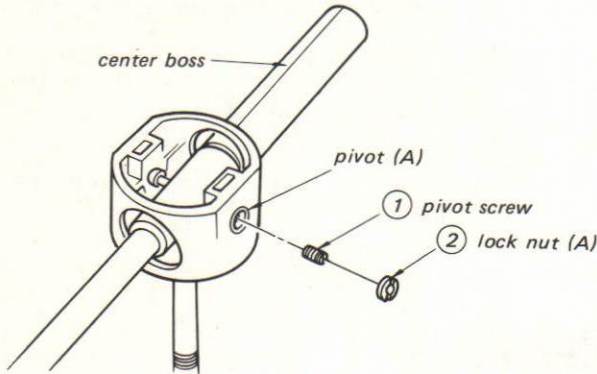

Fig. 3-5

3. Attach the head shell (with a cartridge) and the counterweight to the tonearm.
4. In order to keep a balance, adjust the screw and the nut, repeating the following procedures.
  - a. When the 70 mg weight is placed on the top of the shell (just above a stylus), the tonearm sinks 5 mm (measured at the stylus-tip).
  - b. When the weight is removed, the tonearm returns horizontally.

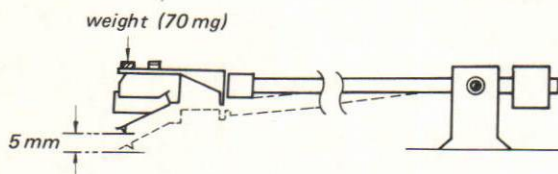

Fig. 3-6

**3-2. INSTALLING TONEARM TO FRAME**

1. Clean the portion of the arm pivot marked by in Fig. 3-7 with an alcohol-moistened swab.
2. Insert the arm shaft in the arm pivot by half.
3. Put fourteen cleaned steel-balls into the portion marked \* .
4. Insert the arm shaft in the arm pivot completely.
5. Hold the tonearm firmly by hand and turn the set upside-down.

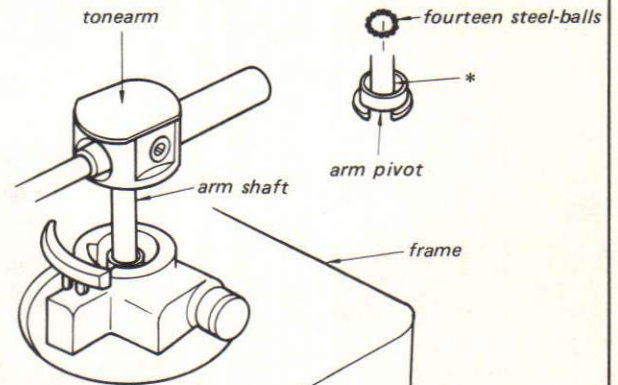

Fig. 3-7

6. Clean the portion marked \* in Fig. 3-8.
7. Put fourteen cleaned steel-balls into the portion marked by \* in Fig. 3-8.

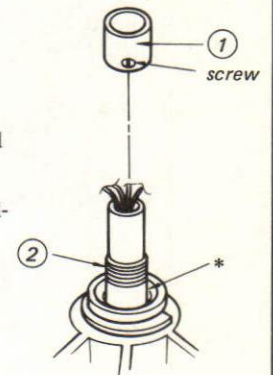

Fig. 3-8

8. Insert the ① (with a screw side down) and screw up the ① to the extent of ② being movable slightly up and down.
9. Tighten the screw with an L-shaped wrench (dia. 1.27 mm).
10. Adjust the stylus-pressure to 750 mg and trace the stylus on the grooveless disk.
11. Confirm that the tonearm traverse smoothly from the outer track to the inner.
12. If not, readjust the ①.

### 3-3. INSTALLATION OF TONEARM

1. Hold the tonearm on the arm rest firmly.
2. Insert the arm lever assembly in the shaft of the tonearm and fix the arm lever assembly temporarily so that the white portion of the arm lever assembly comes off the miniature switch. (OFF position)
3. Move the tonearm by hand and confirm that the neon lamp lights up just when the side of the head shell comes to a distance of 15 mm from the turntable rim as shown in Fig. 3-10.
4. Return the tonearm and confirm that the neon lamp goes off just when the center of the tonearm pipe comes to the tip of the arm rest as shown in Fig. 3-10.
5. Fix the arm lever assembly in the shaft of the tonearm firmly.

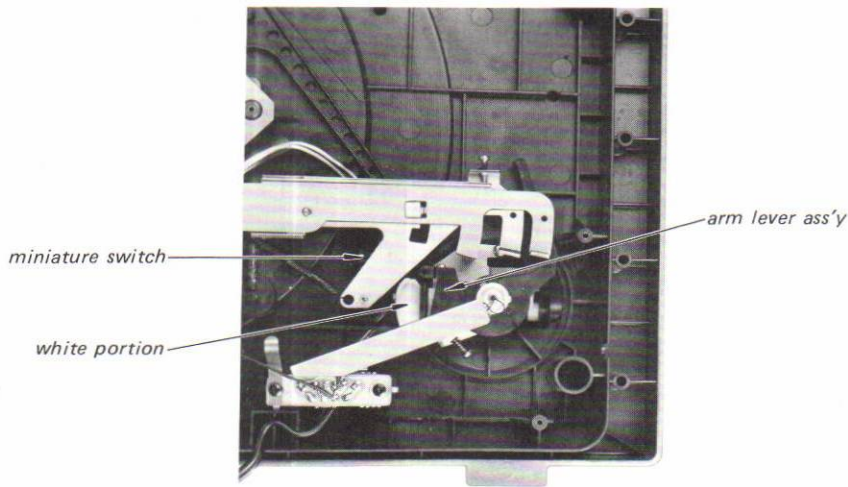

Fig. 3-9

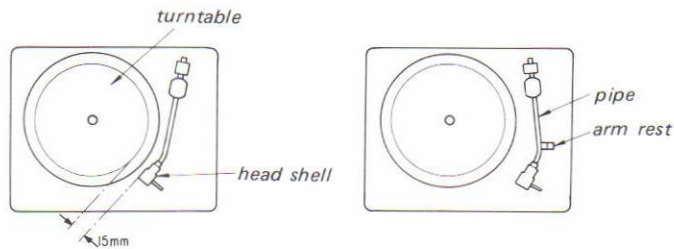

Fig. 3-10



## SECTION 4 LUBRICATION AND CARTRIDGE REPLACEMENT

### 4-1. LUBRICATION

#### Drive Gear

Apply grease to the shaded portion .

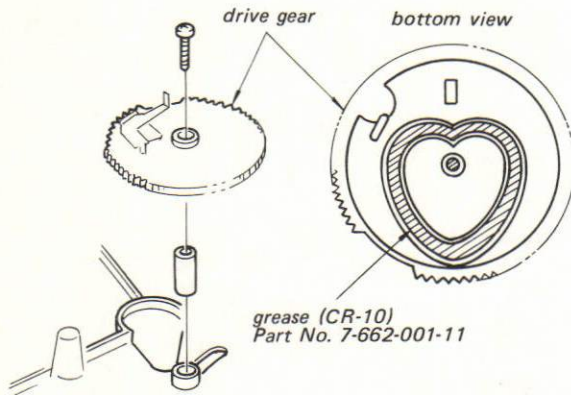

Fig. 4-1

#### Arm Lift

Apply silicone-oil to the shaded portion .

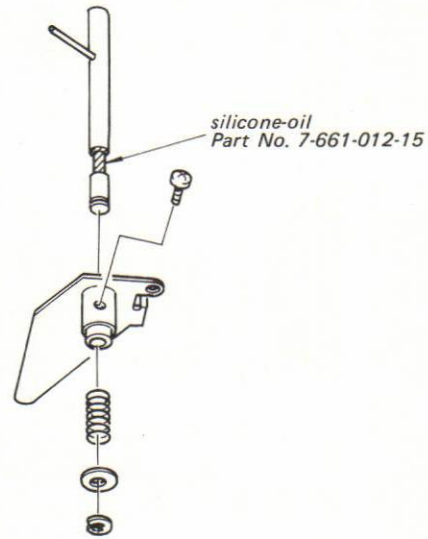

Fig. 4-2

### 4-2. CARTRIDGE REPLACEMENT

#### Position Adjustment

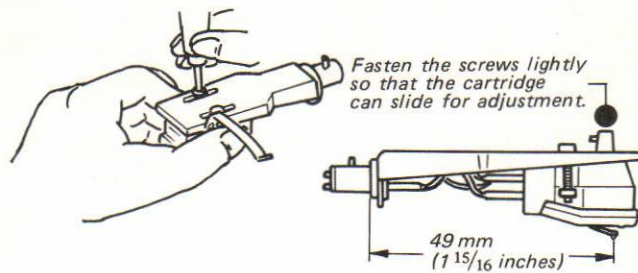

Fig. 4-3

#### Wiring

Wires	Cartridge pins
White . . . . .	L (left channel signal)
Blue . . . . .	LE or G (left channel ground)
Red . . . . .	R (right channel signal)
Green . . . . .	RE or G (right channel ground)

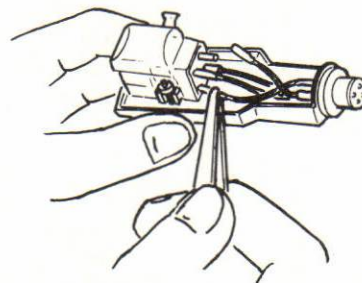

Fig. 4-4

## SECTION 5 MOTOR REPAIRING

The motor and the servo amp board are assembled together. If found defective, disassemble the motor block as shown in Fig. 5-1 and repair it.

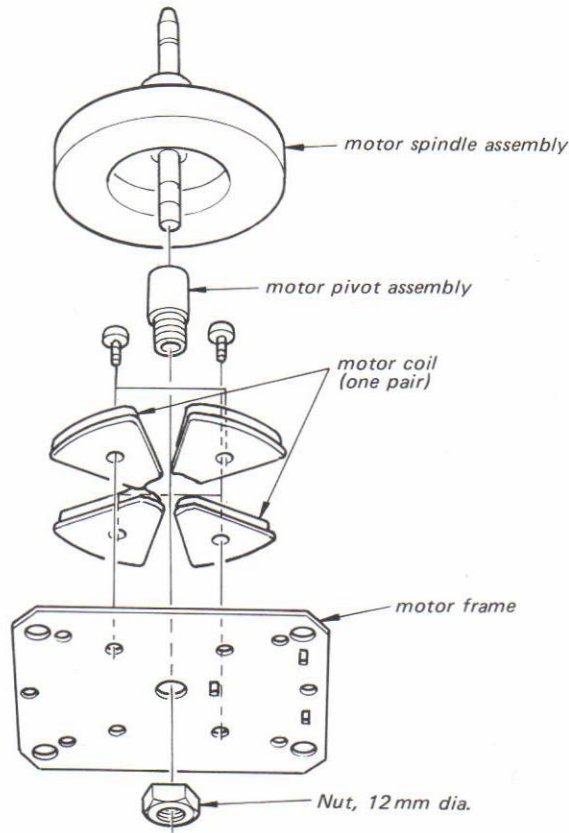

Fig. 5-1

1. When the motor shaft is replaced, lubricate two drops of the SONY oil (OL-2KA) in the pivot
- and apply grease to the parts marked by \* in Fig. 5-2.
2. When the motor pivot assembly is replaced, lubricate two drops of the SONY oil (OL-2KA) in the pivot.

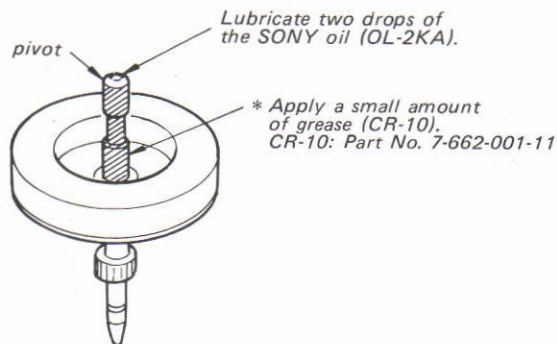

Fig. 5-2



3. Insert the motor shaft assembly slowly in the motor pivot assembly so that the motor shaft is not disturbed by strong magnetic field strength.
4. The motor coils are composed of two pairs.
  - a. Mount the coils on the motor frame so that the boss of the coil is placed in the hole of the frame as illustrated in Fig. 5-3.
  - b. Push the coils in the arrowed direction and tighten the screws.
  - c. Lay the leads of the coils as shown in Fig. 5-4 and fix the leads in the slot between the portions marked by \* in Fig. 5-5.

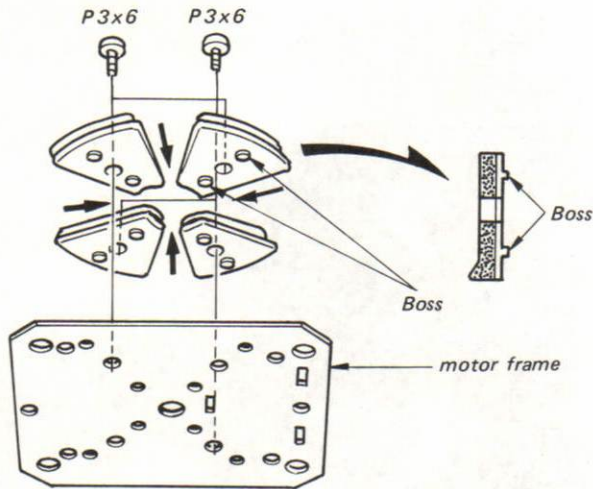

Fig. 5-3

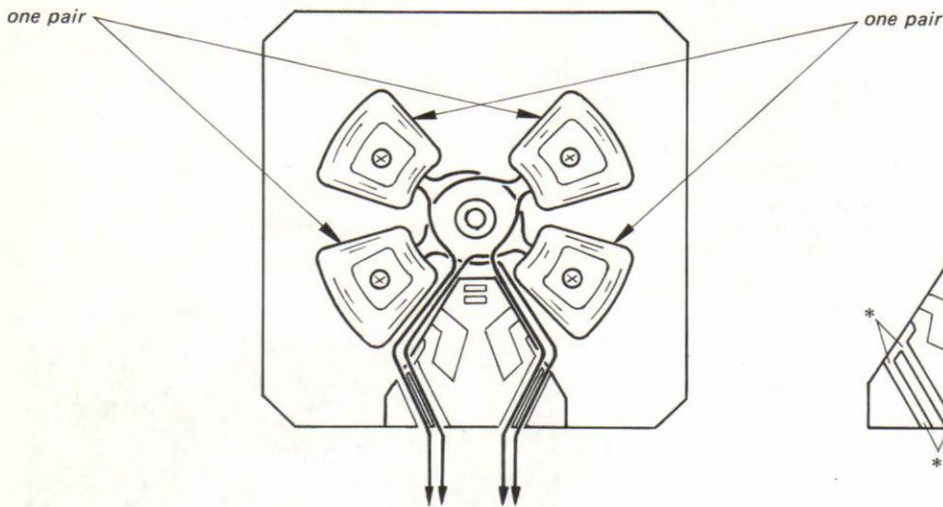

Fig. 5-4

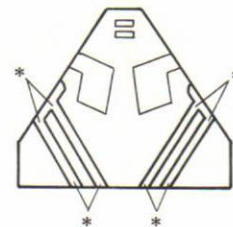

Fig. 5-5

## SECTION 6 ADJUSTMENTS

### 6-1. GAIN ADJUSTMENT

1. Remove the turntable.
2. Unsolder the portion shown by (A) and connect the regulated power supply as illustrated in Fig. 6-1.
3. Connect a VTVM between the emitter Q6/Q8 and the ground.
4. Adjust RV4/RV5 so that the VTVM reading is 2.5 V ac.

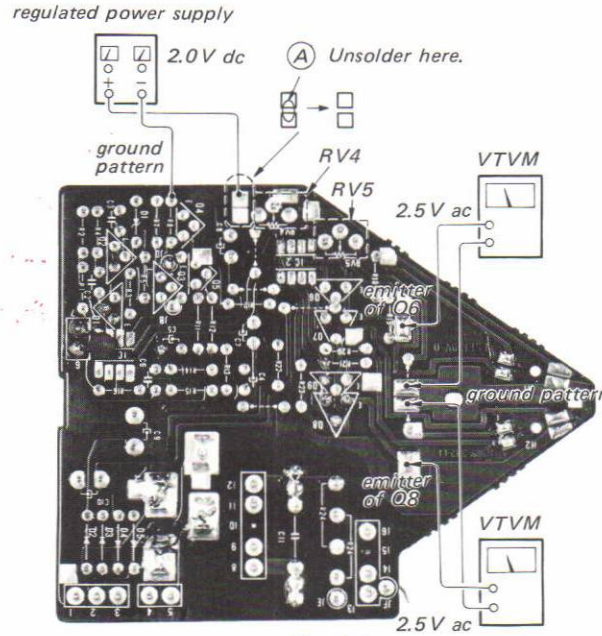

Fig. 6-1

### 6-2. HEAD SHELL SLANT ADJUSTMENT

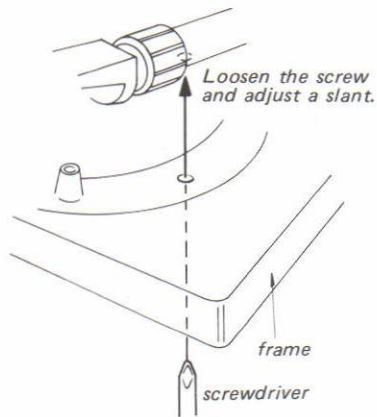

Fig. 6-2

### 6-3. SPEED ADJUSTMENT

In case of being unable to control speed by the PITCH Control, adjust RV2/RV3 (Fig. 6-3) with a screwdriver until the respective stroboscope pattern appears to be stopped.

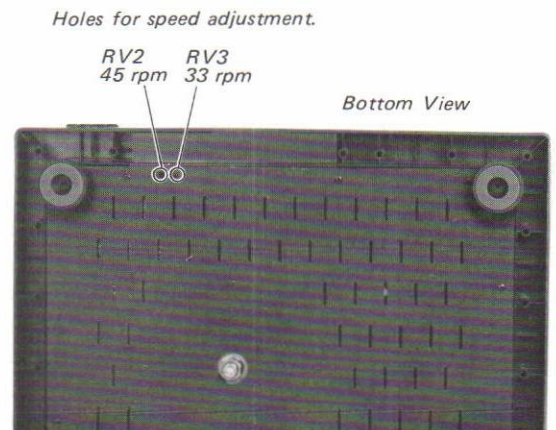

Fig. 6-3



**6-4. AUTOMATIC RETURN POSITION ADJUSTMENT**

1. Remove the turntable and the bottom cover.
2. Reset: Move the clutch A and the clutch B in the arrowed direction as shown in Fig. 6-4B.
3. Adjust the position of the stylus so that the stylus comes to the mark of the boss as shown

in Fig. 6-4A and the hold the stylus.

4. Turn the adjustment screw in Fig. 6-5 so that the portion shown by \*1 of the center gear contacts the portion shown by \*2 of the clutch A as shown in Fig. 6-4B.

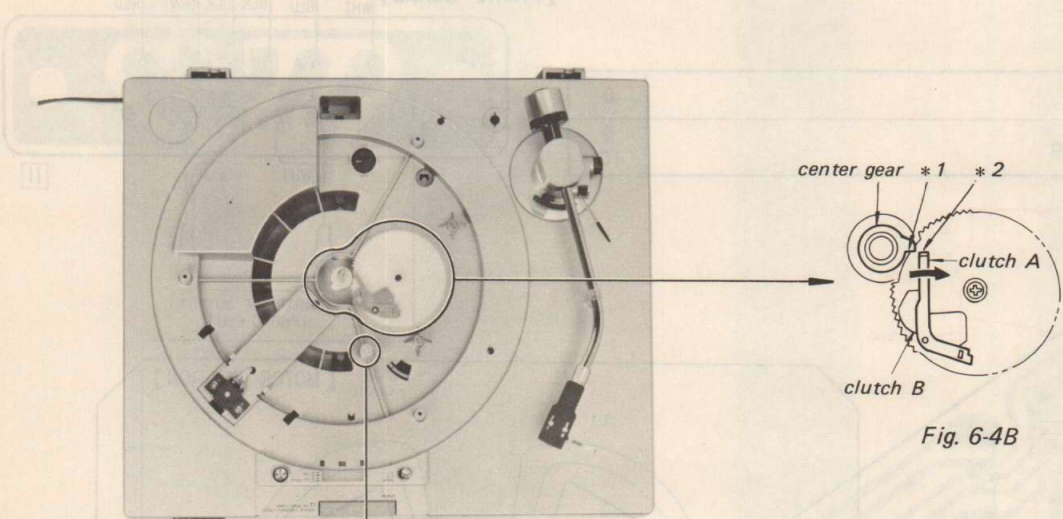

Fig. 6-4

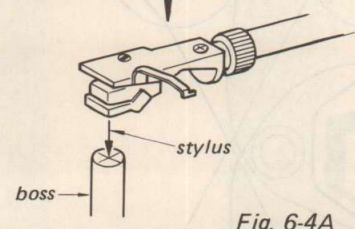

Fig. 6-4A

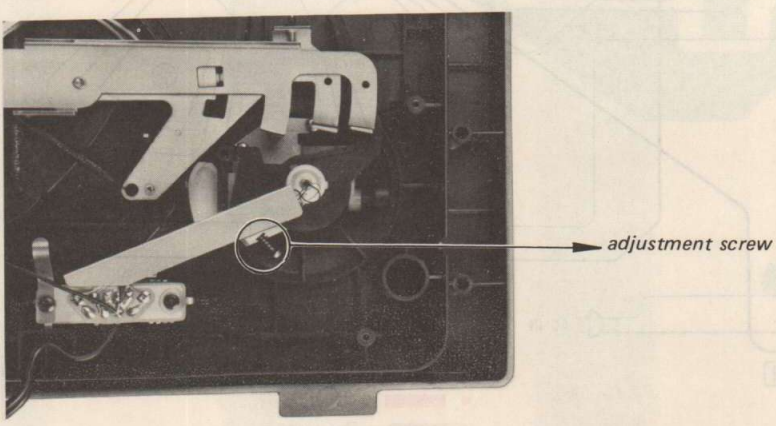

Fig. 6-5

**6-5. SPEED DETECTING HEAD ADJUSTMENT**

1. Fix the speed detecting head temporarily at a distance of 117 mm from the bracket hole to the head tip.
2. Adjust the head position so that the output level of the head exceeds 15 mV ac (at 33 rpm) when the turntable is rotating.

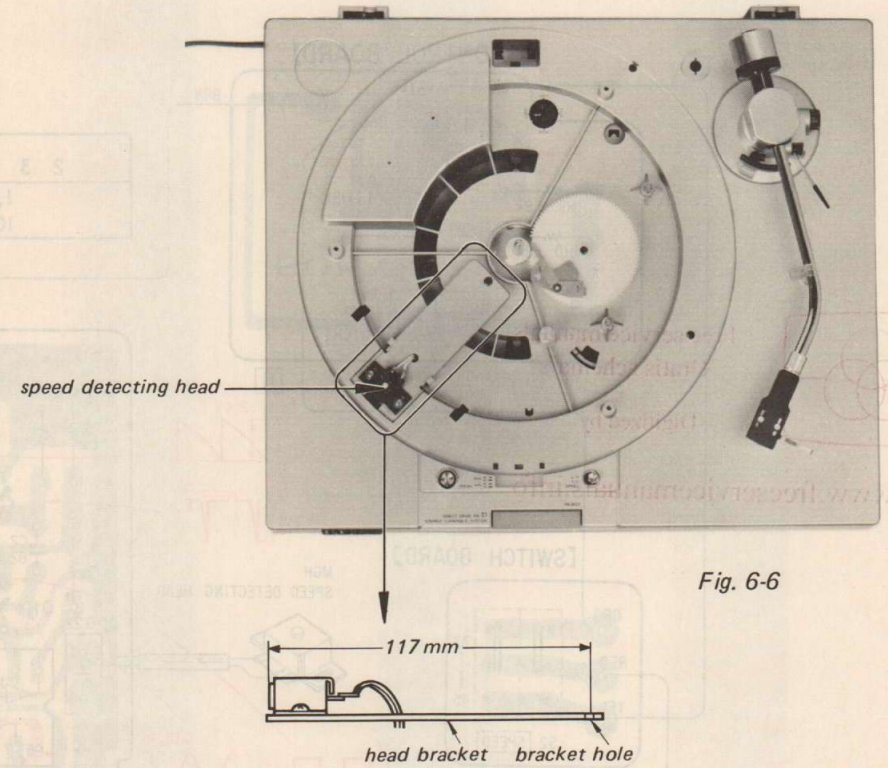

Fig. 6-6

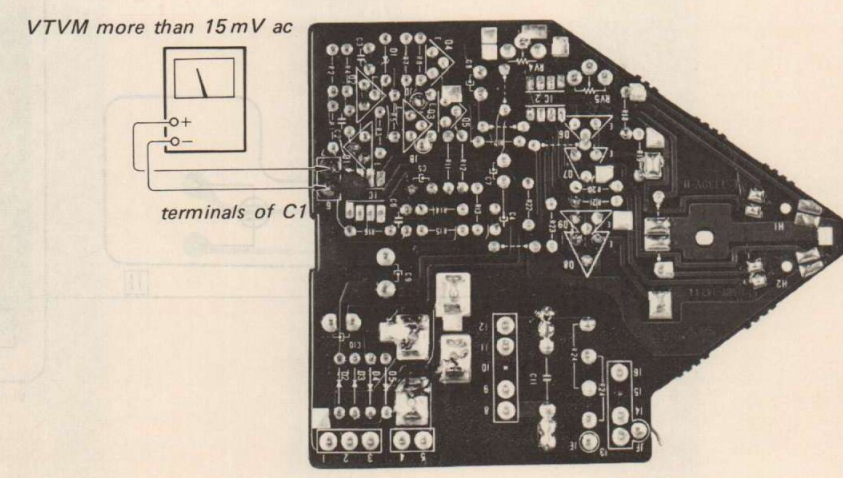

Fig. 6-7

**6-6. MINIATURE SWITCH POSITION ADJUSTMENT**

1. Lock the tonearm on the arm rest.
2. Adjust the adjustment screw so that the positions of the miniature switch and the arm lever assembly are as shown in Fig. 6-8A.
3. Move the tonearm by hand and confirm that the neon lamp lights up just when the head

shell comes to a distance of 15 mm from the turntable rim as shown in Fig. 6-8B.

4. Return the tonearm and confirm that the neon lamp goes off just when the center of the tonearm pipe comes to the tip of the tonearm rest.

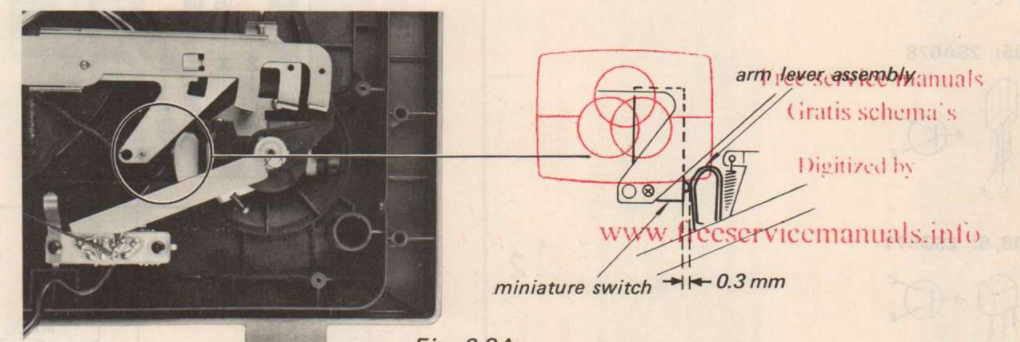

Fig. 6-8A

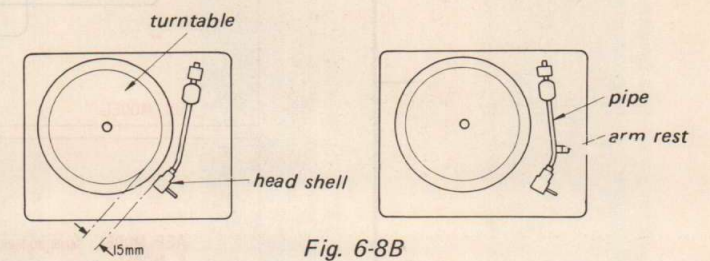

Fig. 6-8B

**6-7. TONEARM HEIGHT ADJUSTMENT**

**Automatic/Manual Return Operation**

Adjust the height of the lift assembly by loosening the set screw so that the clearance between the stylus tip and the record is 5-9 mm, when the tonearm is raised by using the cueing lever after playing.

Check for the same result when the tonearm is automatically raised.

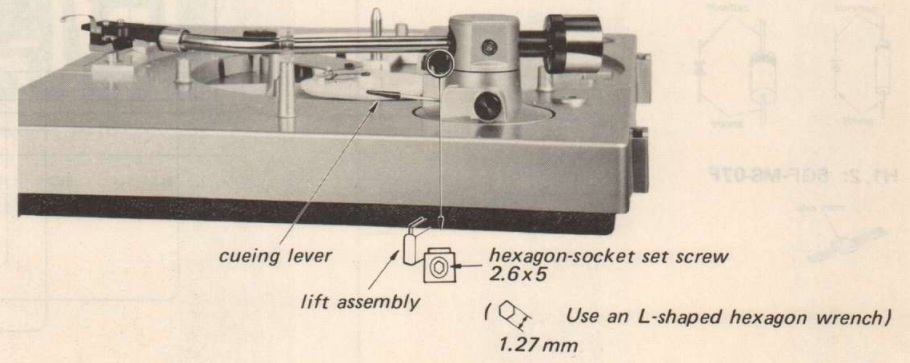

Fig. 6-9



# SECTION 7 DIAGRAM

## 7-1. MOUNTING DIAGRAMS

— Conductor Side —

### Replacement Semiconductors

For replacement, use semiconductors except in ( ).

Q1-4: 2SC1364

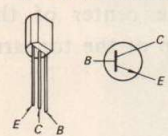

Q5: 2SA678

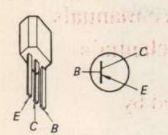

Q6, 8: 2SD571

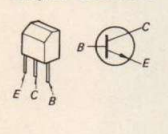

Q7, 9: 2SB605

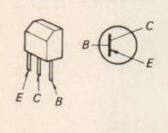

IC1, 2: μPC4558C

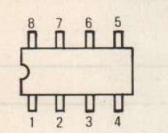

D1: EQB01-05 (EQA01-05R)

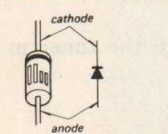

D2-5: 10E-2 (GP08D)

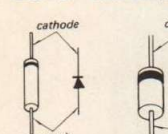

H1, 2: 5GF-MS-07F

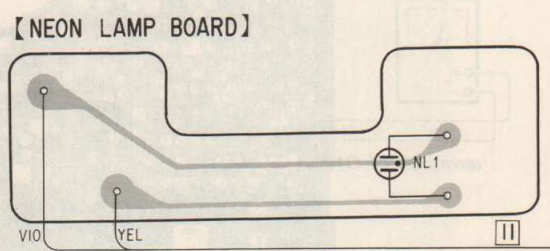
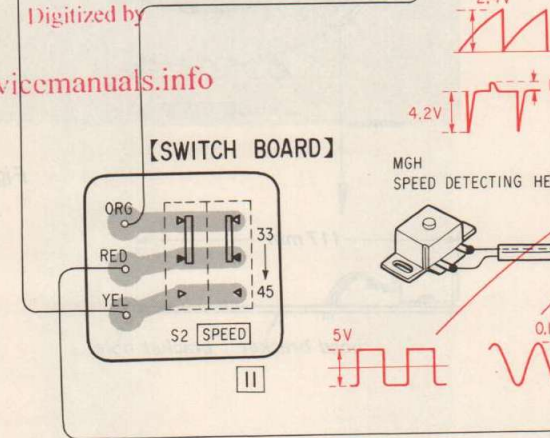
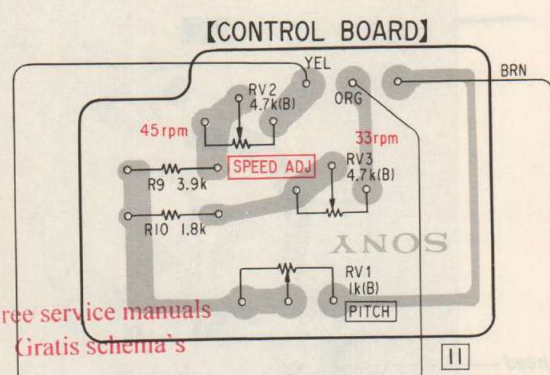
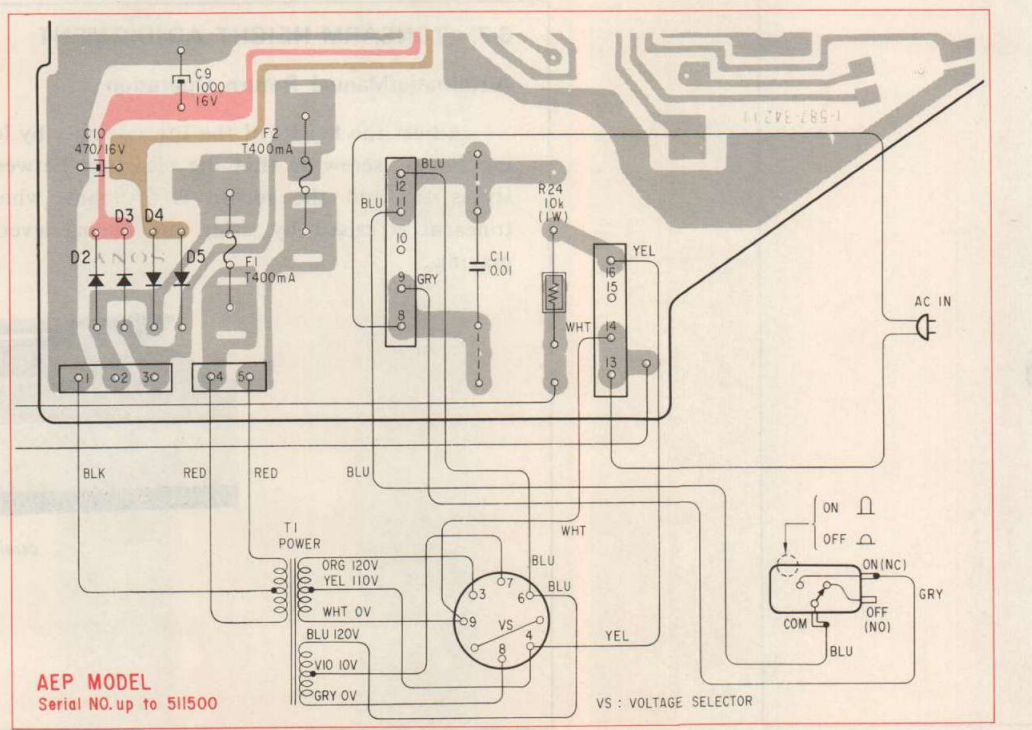
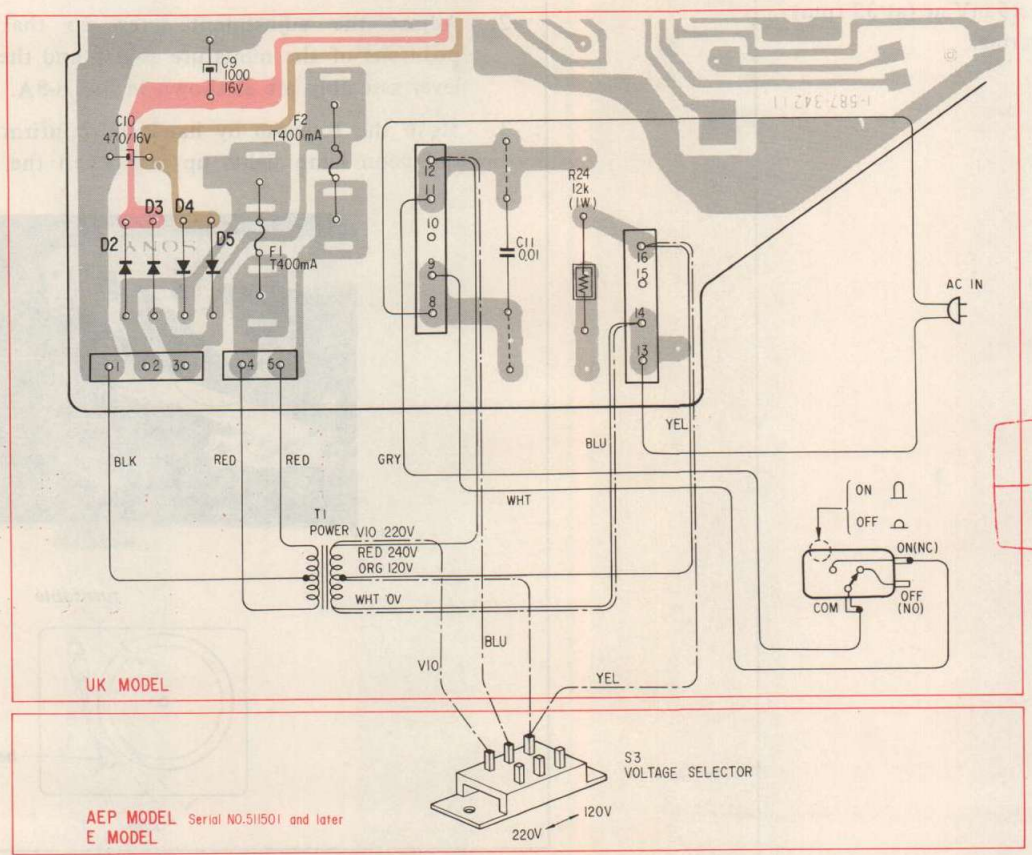
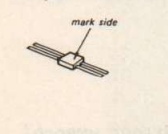

2	3	4	5		D
1,2		4	5	6,7,8,9	Q
IC1					IC

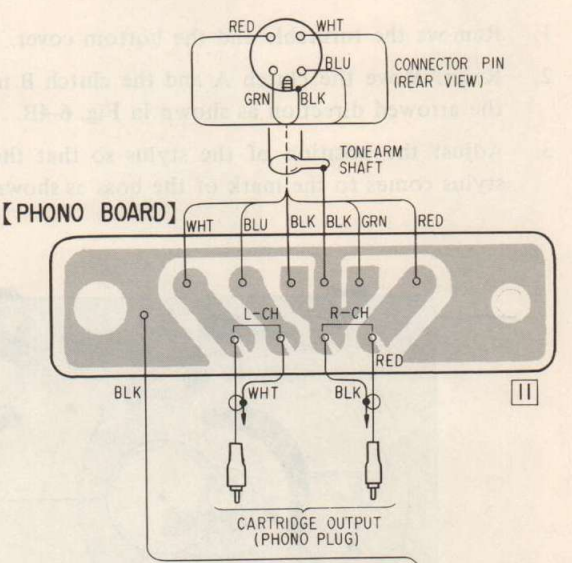
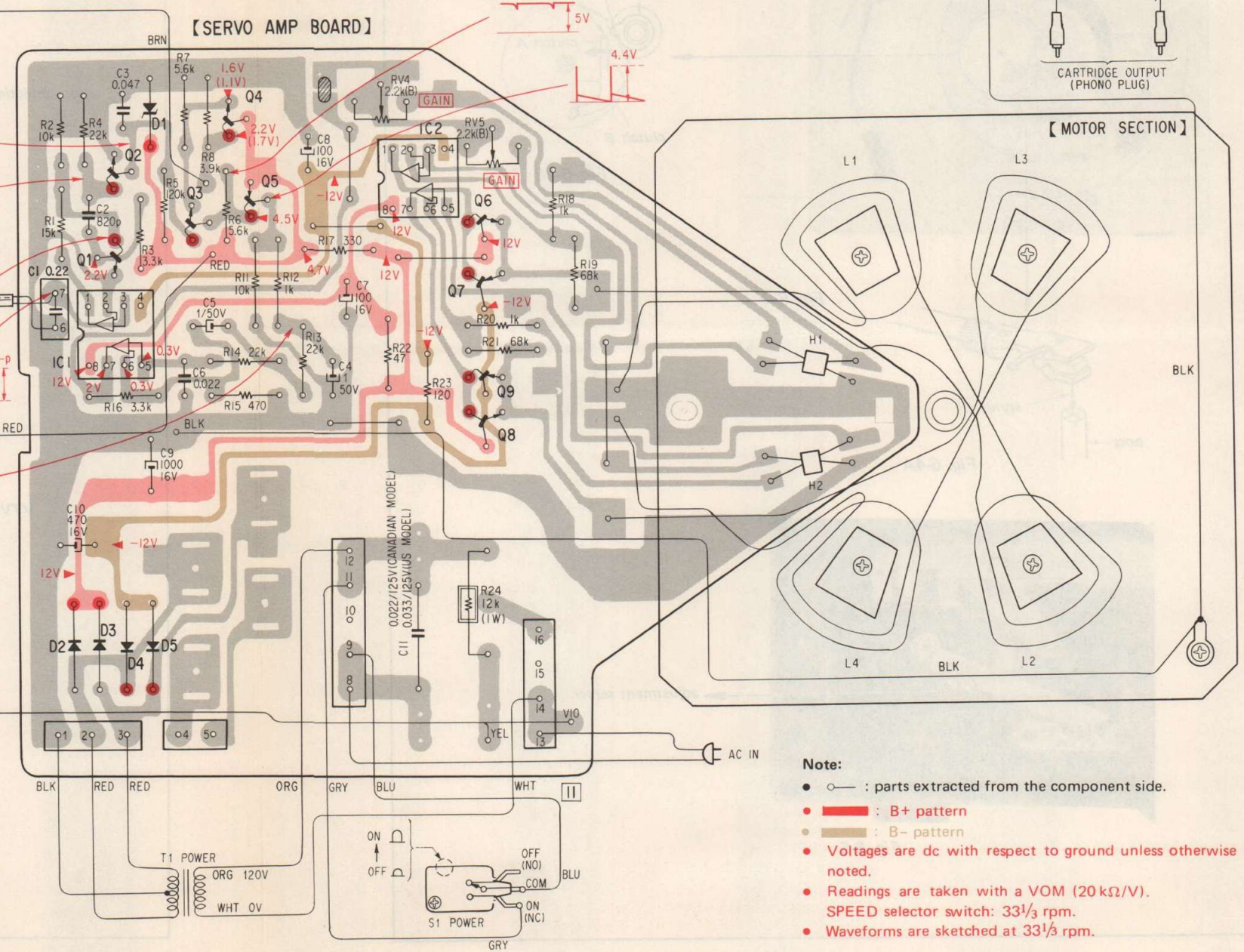

Free service manuals  
Gratis schema's  
Digitized by  
www.freeservicemanuals.info

- Note:**
- : parts extracted from the component side.
  - : B+ pattern
  - : B- pattern
  - Voltages are dc with respect to ground unless otherwise noted.
  - Readings are taken with a VOM (20 kΩ/V). SPEED selector switch: 33 1/3 rpm.
  - Waveforms are sketched at 33 1/3 rpm.



7-2. SCHEMATIC DIAGRAM

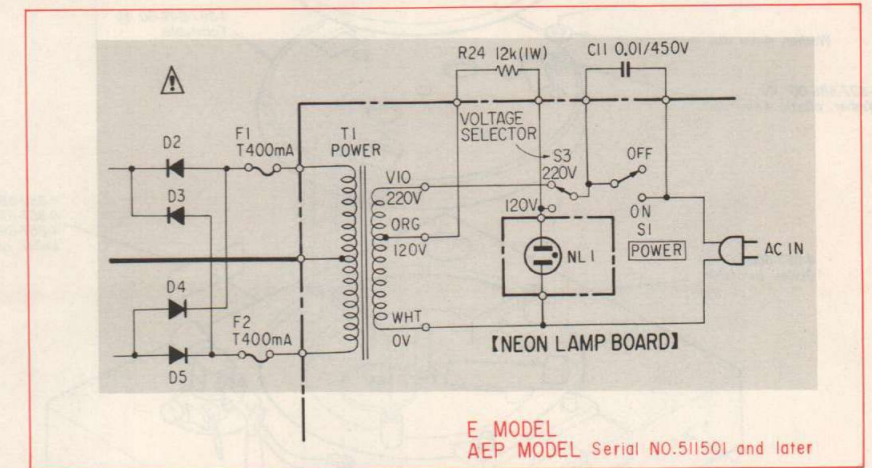
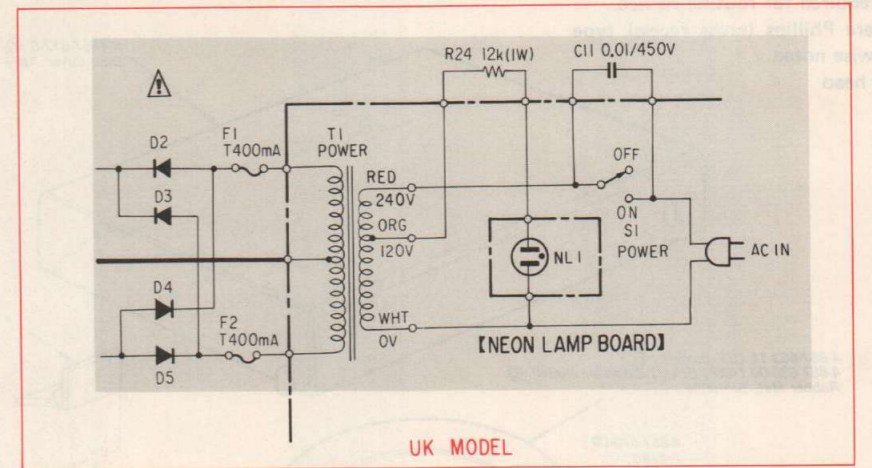
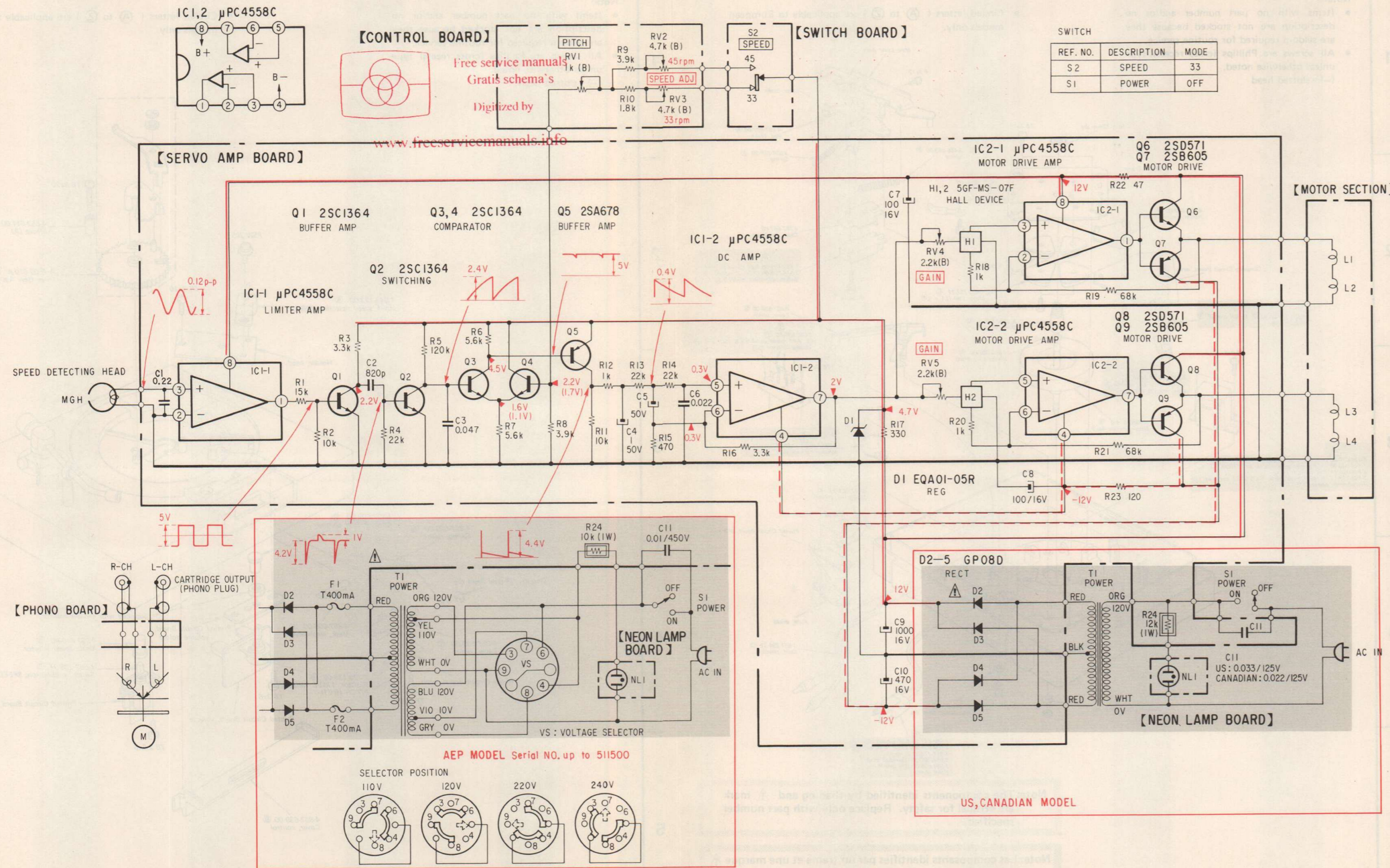

- Note:**
- All capacitors are in μF unless otherwise noted. pF = μμF
  - 50 WV or less are not indicated except for electrolytics.
  - All resistors are in ohms, 1/4 W unless otherwise noted. kΩ = 1000 Ω; MΩ = 1000 kΩ
  - : nonflammable resistor.
  - Voltages are dc with respect to ground unless otherwise noted.
  - Readings are taken with a VOM (20 kΩ/V).
  - Voltage variations may be noted due to normal production tolerances.
  - Waveforms are sketched at 33rpm.
  - : panel designation.
  - : adjustment for repair.
  - : B+ bus.
  - : B- bus.

**Note: The components identified by shading and ⚠ mark are critical for safety. Replace only with part number specified.**

**Note: Les composants identifiés par un trame et une marque ⚠ sont critiques pour la sécurité. Ne les remplacer que par une pièce portant le numéro spécifié.**



SECTION 8  
EXPLODED VIEWS

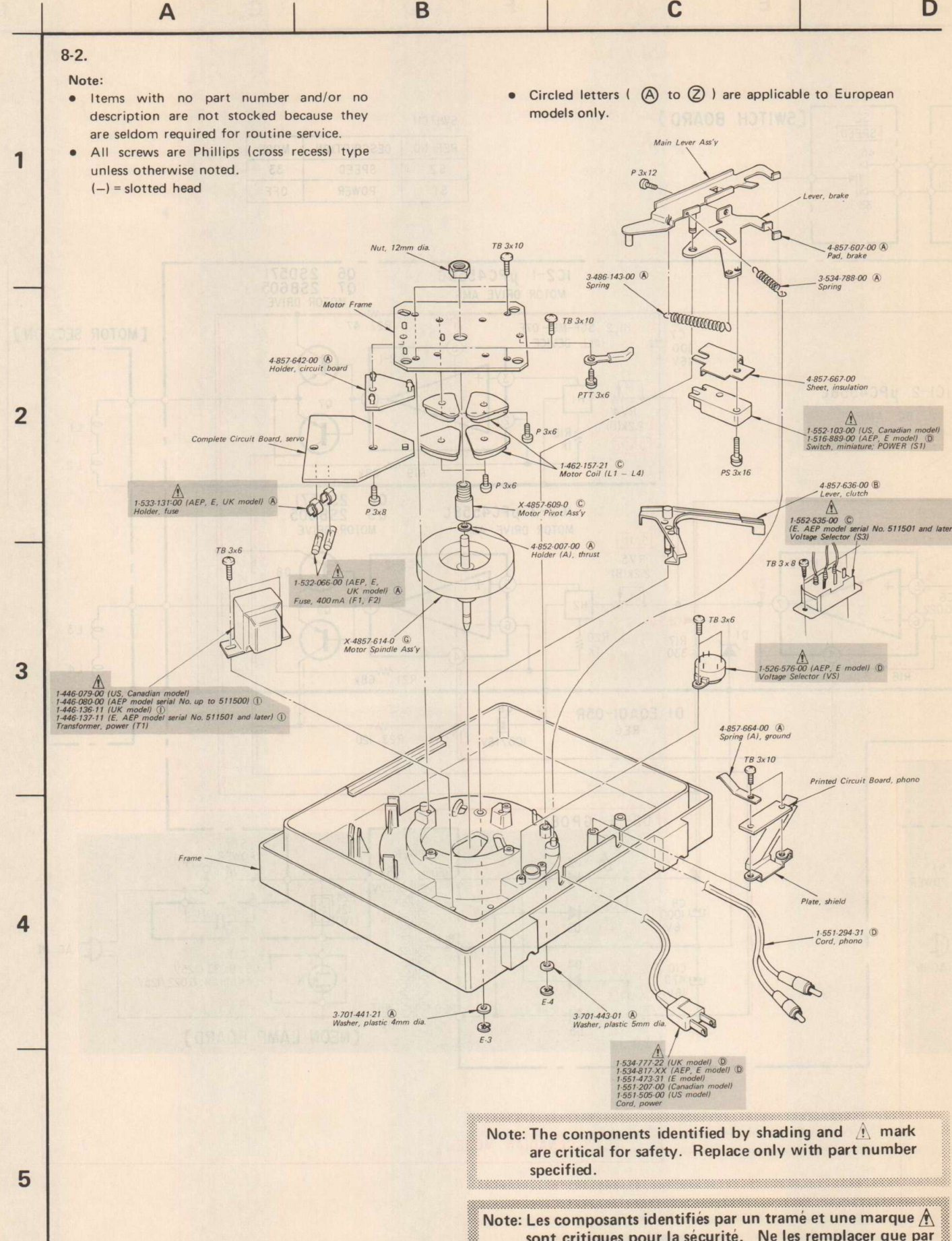
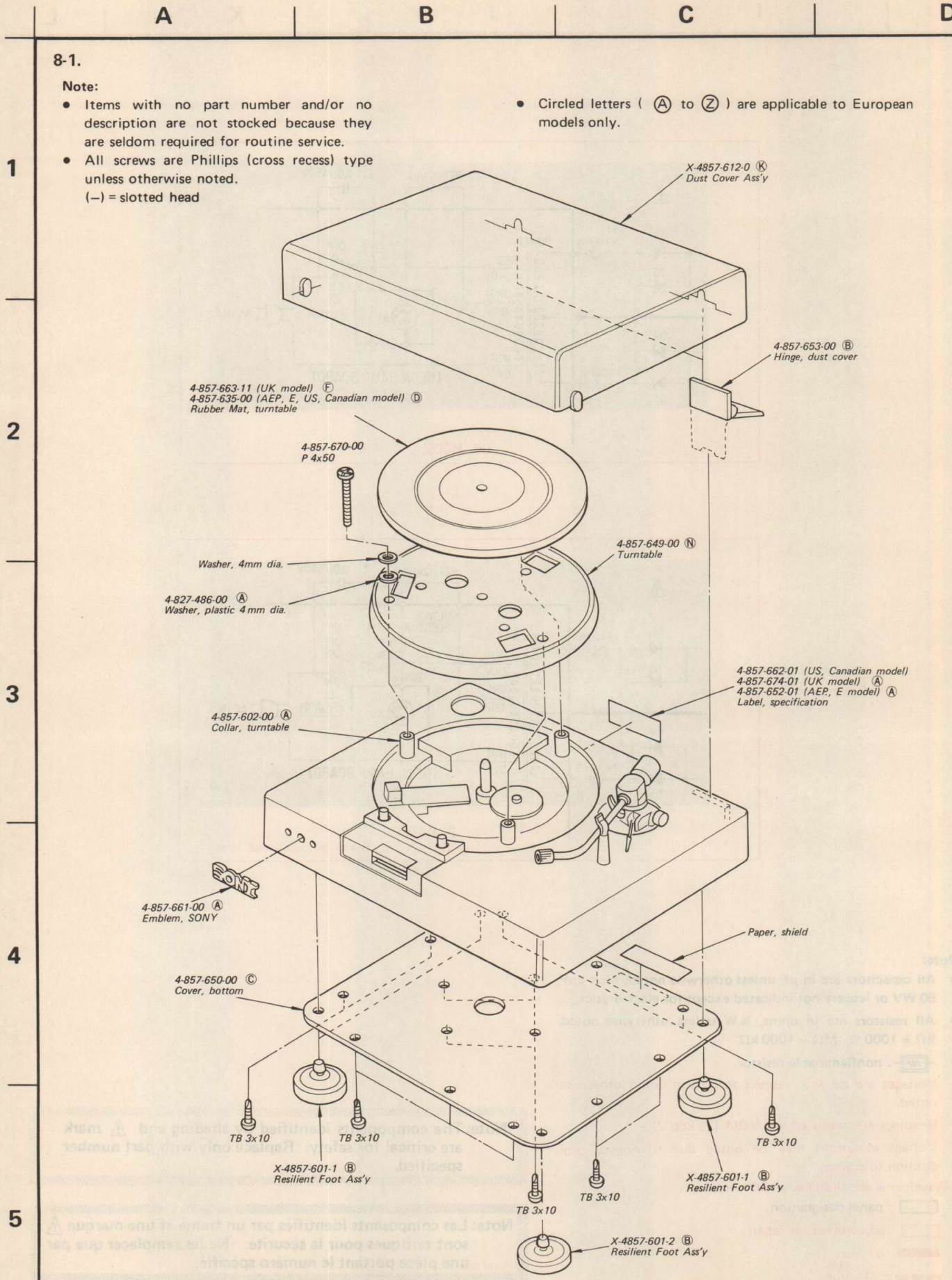

Note: The components identified by shading and ⚠ mark are critical for safety. Replace only with part number specified.

Note: Les composants identifiés par un trame et une marque ⚠ sont critiques pour la sécurité. Ne les remplacer que par une pièce portant le numéro spécifié.

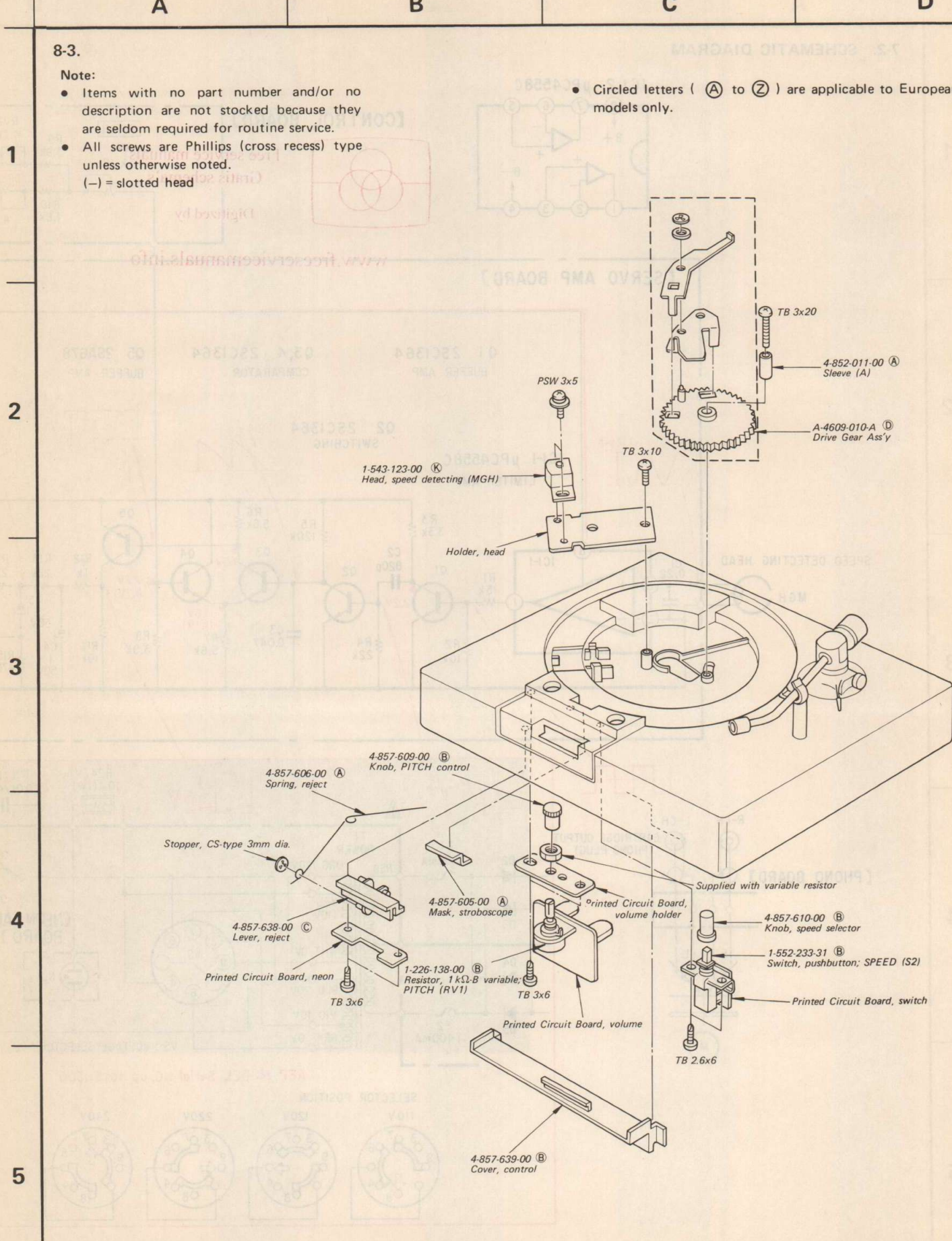



A

B

C

D

8-4.

Note:

- Items with no part number and/or no description are not stocked because they are seldom required for routine service.
- All screws are Phillips (cross recess) type unless otherwise noted.  
(-) = slotted head
- Circled letters (A to Z) are applicable to European models only.

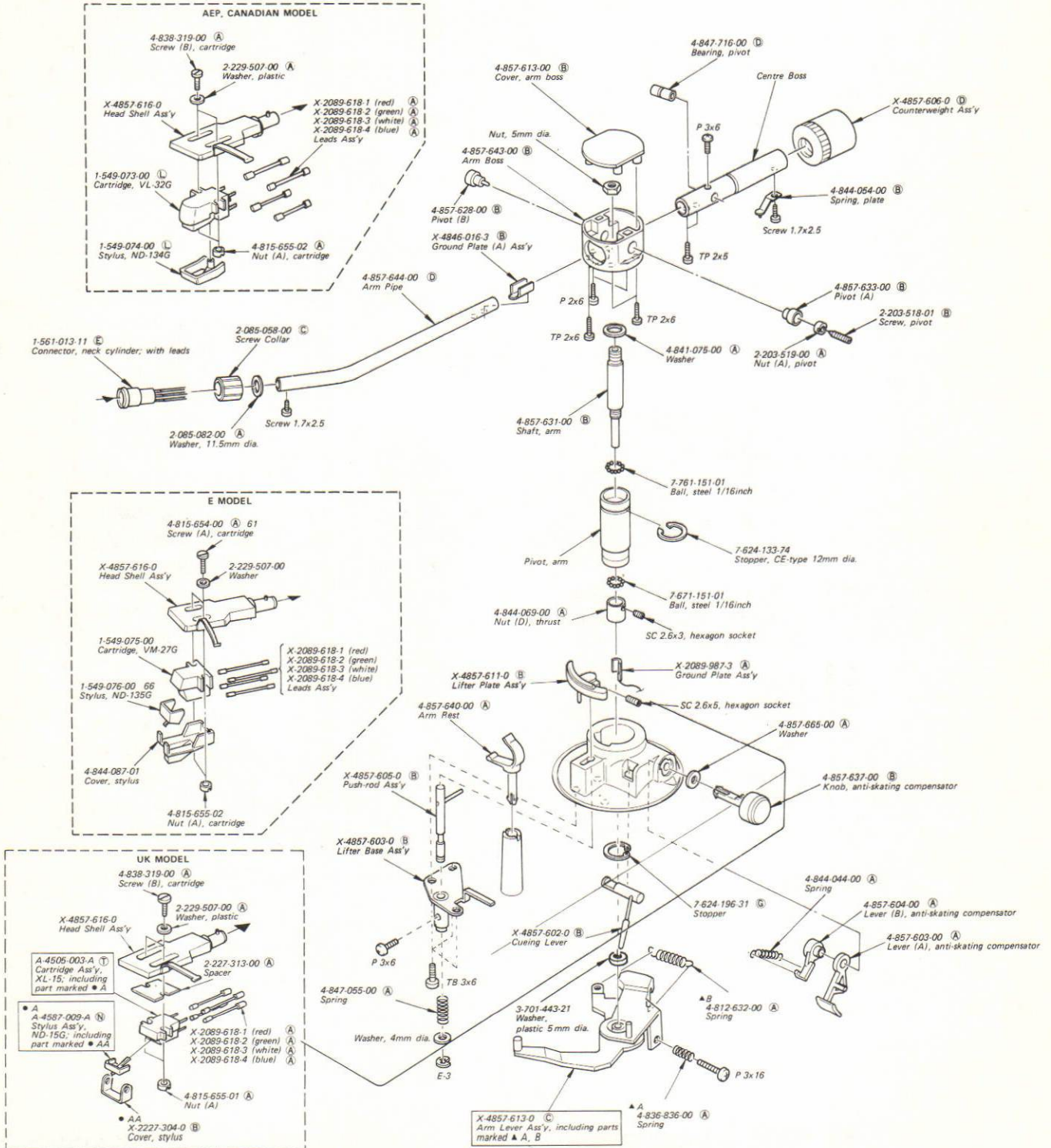

## SECTION 9 ELECTRICAL PARTS LIST

- Circled letters (A to Z) are applicable European models only.

*Ref. No.*      *Part No.*      *Description*

### SEMICONDUCTORS

#### Transistors

Q1-4	8-729-663-47	(B) 2SC1364
Q5	8-727-788-00	(B) 2SA678
Q6	8-729-157-11	(B) 2SD571
Q7	8-729-160-51	(B) 2SB605
Q8	8-729-157-11	(B) 2SD571
Q9	8-729-160-51	(B) 2SB605

#### ICs

IC1,2	8-759-145-58	(D) $\mu$ PC4558C
-------	--------------	-------------------

#### Diodes

⇒ D1	8-719-931-05	(B) EQB01-05
⇒ D2-5	(A) 8-719-200-02	(B) 10E2

#### Hall Elements

H1,2	8-719-905-07	(C) 5GF-MS-07F
------	--------------	----------------

#### COILS

L1-4	1-462-157-21	(C) Motor Coil, stator
------	--------------	------------------------

### TRANSFORMERS

T1	(A) 1-446-079-00	Power (US, Canadian model)
T1	(A) 1-446-080-00	(I) Power (AEP model serial No. up to 511500)
T1	(A) 1-446-136-11	(I) Power (UK model)
T1	(A) 1-446-137-11	(I) Power (E. AEP model serial No. 511501 and later)

### CAPACITORS

All capacitors are in  $\mu$ F. 50WV or less are not indicated except for electrolytics.  
pF =  $\mu$  $\mu$ F, elect = electrolytic

C1	1-108-254-12	(B) 0.22	mylar
C2	1-102-117-11	(A) 820p	ceramic
C3	1-108-812-12	(A) 0.047	mylar
C4,5	1-121-391-11	(A) 1	50V elect
C6	1-161-034-11	(A) 0.022	ceramic
C7,8	1-123-193-11	(A) 100	16V elect
C9	1-121-944-11	(B) 1000	16V elect

⇒: Due to standardization, interchangeable replacements may be substituted for parts specified in the diagrams.

*Ref. No.*      *Part No.*      *Description*

C10	1-121-939-11	(B) 470	16V elect
C11	(A) 1-108-750-12	0.033	125V mylar (US model)
C11	(A) 1-130-098-11	0.022	125V film (Canadian model)
C11	(A) 1-115-148-11	(C) 0.01	450V paper (AEP, E, UK model)

### RESISTORS

All resistors are in ohms. Common  $\frac{1}{4}$ W carbon resistors are omitted.

Check schematic diagram for their values.

R24	(A) 1-213-155-11	(A) 10k, 1W; metal oxide (nonflammable) (AEP model up to serial No. 511500)
R24	(A) 1-213-156-11	12k, 1W; metal oxide (nonflammable) (US, Canadian, E, UK model) (AEP model serial No. 511501 and later)
RV1	1-226-138-00	(B) 1 k-B, variable; PITCH
RV2,3	1-224-633-00	(B) 4.7 k-B, adjustable
RV4,5	1-224-632-00	(B) 2.2 k-B, adjustable

### SWITCHES

S1	(A) 1-552-103-00	Miniature, POWER (US, Canadian model)
S1	(A) 1-516-889-00	(D) Miniature, POWER (AEP, E, UK model)
S2	1-552-233-31	(B) Pushbutton, SPEED 33/45 rpm
S3	(A) 1-552-535-00	(C) Voltage Selector (E. AEP model serial No. 511501 and later)

### MISCELLANEOUS

F1,2	(A) 1-532-066-00	(B) Fuse, 400mA (AEP, E, UK model)
MGH	1-543-123-00	(K) Head, speed detecting
NL1	(A) 1-519-135-11	(B) Neon Lamp
VS	(A) 1-526-576-00	(D) Voltage Selector (AEP model) (serial No. up to 511500)
	A-4505-003-A	(T) Cartridge Assembly; XL-15 (UK model)
	A-4587-009-A	(N) Stylus Assembly; ND-15G (UK model)
	(A) 1-533-131-00	(A) Holder, fuse (AEP, E, UK model)
	(A) 1-534-777-22	(D) Cord, power (UK model)
	(A) 1-534-817-XX	(E) Cord, power (AEP, E model)
	1-549-073-00	(L) Cartridge, VL-32G (AEP, Canadian model)

**Note: The components identified by shading and (A) mark are critical for safety. Replace only with part number specified.**

**Note: Les composants identifiés par un trame et une marque sont critiques pour la sécurité. Ne les remplacer qu'une pièce portant le numéro spécifié.**



- Circled letters ( A to Z ) are applicable to European models only.

<u>Ref. No.</u>	<u>Part No.</u>	<u>Description</u>
1-549-074-00	Ⓛ	Stylus, ND134G (AEP, Canadian model)
1-549-075-00		Cartridge, VM-27G (E model)
1-549-076-00		Stylus, ND135G (E model)
⚠ 1-551-207-00		Cord, power (Canadian model)
1-551-294-31	ⓓ	Cord, phono
⚠ 1-551-473-31		Cord, power (E model)
⚠ 1-551-505-00		Cord, power (US model)
1-561-013-11	ⓔ	Connector, neck cylinder; with leads

#### ACCESSORIES & PACKING MATERIALS

<u>Part No.</u>	<u>Description</u>
3-701-616-00	ⓐ Bag, plastic; counterweight, headshell
3-701-630-00	ⓐ Bag, plastic; instruction manual
3-701-632-00	ⓐ Bag, plastic; turntable spacer
3-701-806-00	ⓐ 45 rpm Adaptor
3-770-497-21	Instruction Manual (US model)
3-794-232-11	Notice (US model)
3-770-497-13	ⓑ Instruction Manual (AEP, E, UK model)
3-794-232-11	ⓒ Notice (AEP, E, UK model)
3-770-497-21	Instruction Manual (Canadian model)
3-794-232-11	Notice (Canadian model)
3-794-220-31	Instruction Manual, French (Canadian model)
4-857-654-00	ⓓ Carton
4-857-655-00	ⓐ Plate (A), protection
4-857-656-00	ⓐ Plate (B), protection
4-857-657-00	ⓑ Bag, protection
4-857-658-00	ⓐ Spacer, turntable
4-857-659-00	ⓑ Cushion, right
4-857-660-00	ⓑ Cushion, left

**Note: The components identified by shading and ⚠ mark are critical for safety. Replace only with part number specified.**

**Note: Les composants identifiés par un trame et une marque ⚠ sont critiques pour la sécurité. Ne les remplacer que par une pièce portant le numéro spécifié.**



**PS-TI**

**MODEL IDENTIFICATIONS**

— Specification Label —

US, Canadian model

<b>SONY</b> <sup>®</sup>	STEREO TURNTABLE SYSTEM		
	MODEL NO.PS-TI		
	AC 120V	60Hz	6W
	SERIAL NO. _____		
	MADE IN JAPAN		

AEP, E model

<b>SONY</b> <sup>®</sup>	STEREO TURNTABLE SYSTEM		
	MODEL NO.PS-TI		
	~ 120 220V	50/60Hz	8W
	SERIAL NO. _____		
	MADE IN JAPAN		

UK model

<b>SONY</b> <sup>®</sup>	STEREO TURNTABLE SYSTEM		
	MODEL NO.PS-TI		
	~ 240V	50/60Hz	8W
	SERIAL NO. _____		
	MADE IN JAPAN		

**Sony Corporation**

© 1978

— 36 —

# STEREO TURNTABLE SYSTEM

# PS-T1

Canadian Model  
US Model  
AEP Model  
UK Model  
E Model

## CORRECTION

No. 1  
July, 1978

Subject: Wiring of voltage selector and transformer

 : corrected portion  
SCHEMATIC DIAGRAM  
Page 29

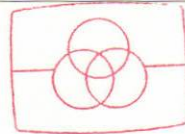

Free service manuals  
Gratis schema's

Digitized by

www.freeservicemanuals.info

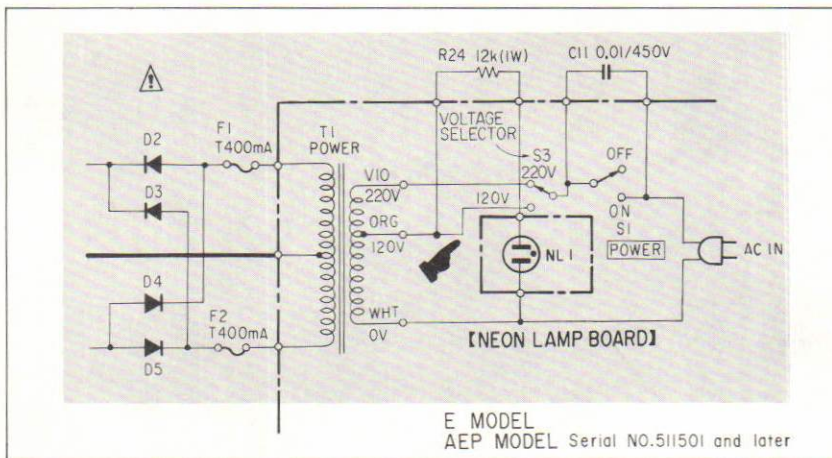

# SONY<sup>®</sup>

## SERVICE MANUAL

Sony Corporation

© 1978

780649-1  
Printed in Japan