

DVD Micro System**MCD708**

all versions

Service Service Service

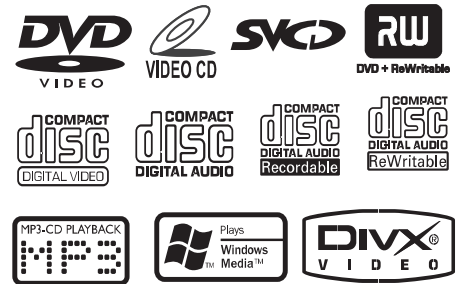

Service Manual

**TABLE OF CONTENTS**

Handling chip components	1-1
Information about lead-free soldering	1-2
Technical specification	2-1
Service tools	2-1
Service measurement setup	2-2
Connections and controls	3-1...3-4
Disassembly diagram	4-1...4-2
Software version and upgrading	5-1
Set block diagram	5-2
Set wiring diagram	5-3
VFD BOARD	
circuit diagram	6-1
layout diagram	6-2
TUNER BOARD	
circuit diagram	7-1
layout diagram	7-2
layout diagram-amp box pcb assy	7-2

AMP BOARD	
circuit diagram	8-1
layout diagram	8-2
CPU BOARD	
circuit diagram	9-1
layout diagram	9-2
ALC VOLUME BOARD	
circuit diagram	10-1
layout diagram	10-2
DVD MPEG BOARD	
circuit diagram	11-1...11-5
layout diagram	11-6
Exploded view diagram	12-1
Mechanical partslist	12-2
Electrical partslist	13-1...13-4
Revision list	14-1

**CLASS 1
LASER PRODUCT**

© Copyright 2006 Philips Consumer Electronics B.V. Eindhoven, The Netherlands
All rights reserved. No part of this publication may be reproduced, stored in a retrieval system or transmitted, in any form or by any means, electronic, mechanical, photocopying, or otherwise without the prior permission of Philips.

Published by LX 0612 Service Audio Printed in The Netherlands Subject to modification

GB 3141 785 30732

Version 1.2



PHILIPS

1 - 1

HANDLING CHIP COMPONENTS

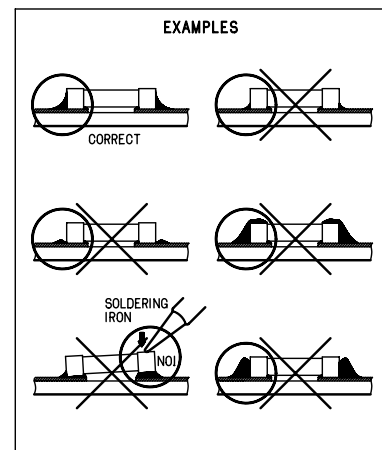
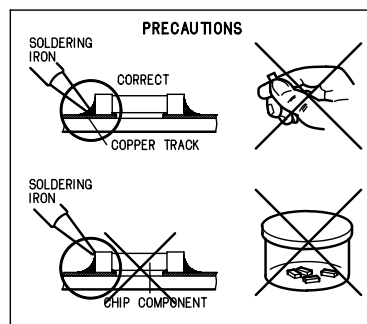
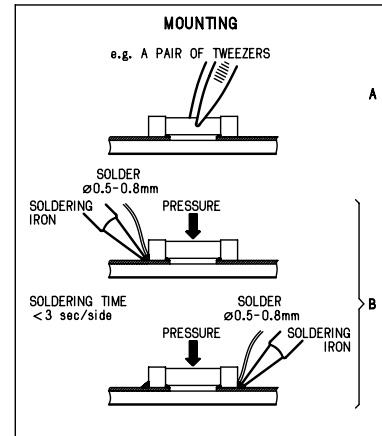
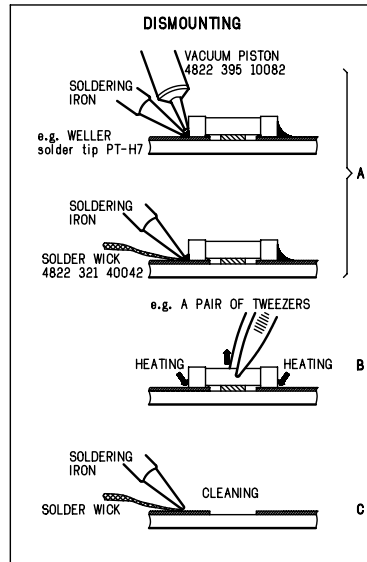
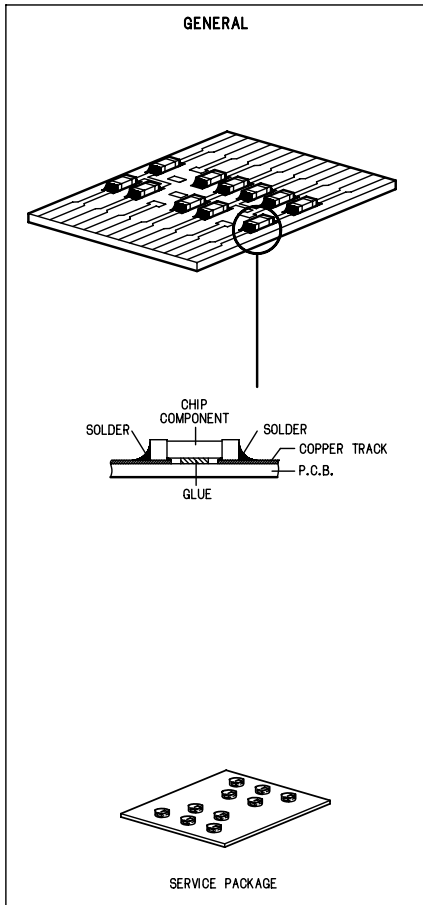
**(GB) WARNING**

All ICs and many other semiconductors are susceptible to electrostatic discharges (ESD). Careless handling during repair can reduce life drastically. When repairing, make sure that you are connected with the same potential as the mass of the set via a wristband with resistance. Keep components and tools at this potential.

ESD**(NL) WAARSCHUWING**

Alle IC's en vele andere halfgeleiders zijn gevoelig voor electrostatische ontladingen (ESD). Onzorgvuldig behandelen tijdens reparatie kan de levensduur drastisch doen verminderen. Zorg ervoor dat u tijdens reparatie via een polsband met weerstand verbonden bent met hetzelfde potentiaal als de massa van het apparaat. Houd componenten en hulpmiddelen ook op ditzelfde potentiaal.

(F) ATTENTION

Tous les IC et beaucoup d'autres semi-conducteurs sont sensibles aux décharges statiques (ESD). Leur longévité pourrait être considérablement écourtée par le fait qu'aucune précaution n'est prise à leur manipulation. Lors de réparations, s'assurer de bien être relié au même potentiel que la masse de l'appareil et enfilier le bracelet sert d'une résistance de sécurité. Veiller à ce que les composants ainsi que les outils que l'on utilise soient également à ce potentiel.

(D) WARNUNG

Alle ICs und viele andere Halbleiter sind empfindlich gegenüber elektrostatischen Entladungen (ESD). Unvorsichtige Behandlung im Reparaturfall kann die Lebensdauer drastisch reduzieren. Sorgen Sie dafür, daß Sie im Reparaturfall über ein Pulsarmband mit Widerstand mit dem Massepotential des Gerätes verbunden sind. Halten Sie Bauteile und Hilfsmittel ebenfalls auf diesem Potential.

(I) AVVERTIMENTO

Tutti IC e parecchi semi-conduttori sono sensibili alle scariche statiche (ESD). La loro longevità potrebbe essere fortemente ridotta in caso di non osservazione della più grande cauzione alla loro manipolazione. Durante le riparazioni occorre quindi essere collegato allo stesso potenziale che quello della massa dell'apparecchio tramite un braccialeto a resistenza. Assicurarsi che i componenti e anche gli utensili con quali si lavora siano anche a questo potenziale.

(GB)

Safety regulations require that the set be restored to its original condition and that parts which are identical with those specified be used. Safety components are marked by the symbol ▲

(F)

Les normes de sécurité exigent que l'appareil soit remis à l'état d'origine et que soient utilisées les pièces de rechange identiques à celles spécifiées. Les composants de sécurité sont marqués ▲

SAFETY**(D)**

Bei jeder Reparatur sind die geltenden Sicherheitsvorschriften zu beachten. Der Originalzustand des Gerätes darf nicht verändert werden. Für Reparaturen sind Originalersatzteile zu verwenden. Sicherheitsbauteile sind durch das Symbol ▲ markiert.

(NL)

Veiligheidsbepalingen vereisen, dat het apparaat in zijn oorspronkelijke toestand wordt teruggebracht en dat onderdelen, identiek aan de gespecificeerde, worden toegepast. De Veiligheidsonderdelen zijn aangeduid met het symbool ▲

(I)

Le norme di sicurezza estigono che l'apparecchio venga rimesso nelle condizioni originali e che siano utilizzati i pezzi di ricambio identici a quelli specificati. Componenti di sicurezza sono marcati con ▲

(GB) DANGER: Invisible laser radiation when open. AVOID DIRECT EXPOSURE TO BEAM.

(S) Varning !

Osynlig laserstrålning när apparaten är öppnad och spärrar är urkopplad. Betrakta ej strålen.

(DK) Advarsel !

Usynlig laserstrålning ved åbning når sikkerhedsafbrydere er ude af funktion. Undgå udsættelse for stråling.

**(FIN) Varoitus !**

Avatussa laitteessa ja suojalukituksen ohitettaessa olet alttiina näkymättömälle laserisäteilylle. Älä katso säteeseen !

(GB)

After servicing and before returning the set to customer perform a leakage current measurement test from all exposed metal parts to earth ground, to assure no shock hazard exists. The leakage current must not exceed 0.5mA.

(F)

"Pour votre sécurité, ces documents doivent être utilisés par des spécialistes agréés, seuls habilités à réparer votre appareil en panne".

INFORMATION ABOUT LEAD-FREE SOLDERING

Philips CE is producing lead-free sets from 1.1.2005 onwards.

IDENTIFICATION:

Regardless of special logo (not always indicated) one must treat all sets from 1 Jan 2005 onwards, according next rules:



Example S/N:

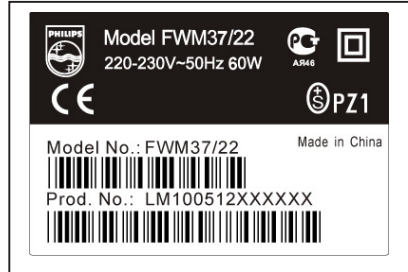

Bottom line of typeplate gives a 14-digit S/N. Digit 5&6 is the year, digit 7&8 is the week number, so in this case 2005 wk12

So from 0501 onwards = from 1 Jan 2005 onwards

Important note: In fact also products of year 2004 must be treated in this way as long as you avoid mixing solder-alloys (leaded/lead -free). So best to always use SAC305 and the higher temperatures belong to this.

Due to lead-free technology some rules have to be respected by the workshop during a repair:

- Use only lead-free solder alloy Philips SAC305 with order code 0622 149 00106. If lead-free solder-paste is required, please contact the manufacturer of your solder-equipment. In general use of solder-paste within workshops should be avoided because paste is not easy to store and to handle.
- Use only adequate solder tools applicable for lead-free solder alloy. The solder tool must be able
 - To reach at least a solder-temperature of 400°C,
 - To stabilize the adjusted temperature at the solder-tip
 - To exchange solder-tips for different applications.
- Adjust your solder tool so that a temperature around 360°C – 380°C is reached and stabilized at the solder joint. Heating-time of the solder-joint should not exceed ~ 4 sec. Avoid temperatures above 400°C otherwise wear-out of tips will rise drastically and flux-fluid will be destroyed. To avoid wear-out of tips switch off un-used equipment, or reduce heat.
- Mix of lead-free solder alloy / parts with leaded solder alloy / parts is possible but PHILIPS recommends strongly to avoid mixed solder alloy types (leaded and lead-free).
If one cannot avoid or does not know whether product is lead-free, clean carefully the solder-joint from old solder alloy and re-solder with new solder alloy (SAC305).
- Use only original spare-parts listed in the Service-Manuals. Not listed standard-material (commodities) has to be purchased at external companies.
- **Special information for BGA-ICs:**
 - always use the 12nc-recognizable soldering temperature profile of the specific BGA (for de-soldering always use the lead-free temperature profile, in case of doubt)
 - lead free BGA-ICs will be delivered in so-called 'dry-packaging' (sealed pack including a silica gel pack) to protect the IC against moisture. After opening, dependent of MSL-level seen on indicator-label in the bag, the BGA-IC possibly still has to be baked dry. (MSL=Moisture Sensitivity Level). This will be communicated via AYS-website.
 - Do not re-use BGAs at all.
- For sets produced before 1.1.2005 (except products of 2004), containing leaded solder-alloy and components, all needed spare-parts will be available till the end of the service-period. For repair of such sets nothing changes.
- On our website www.atyourservice.ce.Philips.com you find more information to:
 - * BGA-de-/soldering (+ baking instructions)
 - * Heating-profiles of BGAs and other ICs used in Philips-sets

You will find this and more technical information within the "magazine", chapter "workshop news".

For additional questions please contact your local repair-helpdesk.

SERVICE INSTRUCTION

Safety regulations require that after a repair, the set must be returned in its original condition. Pay in particular attention to the following points:

- Route the wire trees correctly and fix them with the mounted cable clamps.
- Check the insulation of the AC Power lead for external damage.
- Check the strain relief of the AC Power cord for proper function.
- Check the electrical DC resistance between the AC Power Plug and the secondary side (only for sets which have a AC Power isolated power supply):
 1. Unplug the AC Power cord and connect a wire between the two pins of the AC Power plug.
 2. Set the AC Power switch to the "on" position (keep the AC Power cord unplugged!).
 3. Measure the resistance value between the pins of the AC Power plug and the metal shielding of the tuner or the aerial connection on the set. The reading should be larger than 4.5 Mohm (For U.S. it should be between 4.2 Mohm and 12 Mohm).
 4. Switch "off" the set, and remove the wire between the two pins of the AC Power plug.
- Check the cabinet for defects, to avoid touching of any inner parts by the customer.

TECHNICAL SPECIFICATIONS

GENERAL

Mains voltage	-/93 : 220V -/98 : 120/230V -/12 : 230V -/79 : 240V
Mains frequency	-/93 : 50 Hz -/98 : 50/60 Hz -/12 : 50 Hz -/79 : 50 Hz
Battery	remote : 3 V (AAA x 2)
Power consumption	normal : < 55W Standby : < 4 W
Dimension (W x H x D)	: 147 x 232 x 223 mm
Weight (excluding packing and batteries)	: 5.15 Kg

AMPLIFIER

Output power	mains : 2 x 50W
Speaker impedance	mains : 2 x 4 ohm
Frequency response	: 20 Hz - 20 kHz (± 3 dB)

TUNER - FM SECTION

Tuning range	: 87.5 - 108 MHz
IF frequency	: 10.7 MHz \pm 0.02 MHz
Sensitivity	: < 22 dBf at 26dB
Selectivity	300kHz : > 33 dB
IF Rejection	: > 60 dB
Image Rejection	: > 25dB
Distortion	: < 3 %
Tuning Grid	: 100/50K Hz

TUNER - AM SECTION

Tuning range	: 531 - 1602 kHz
Tuning Grid	: 9/10K Hz
IF frequency	: 450 kHz \pm 1 kHz
Sensitivity	: \leq 3.25 mV/m at 26dB
Selectivity S9/300kHz	: > 12 dB
IF rejection	: > 24 dB
Distortion	: < 5%
Image rejection	: > 20 dB

DVD / MP3 / CD

Laser Type	: Semiconductor
Disc Diameter	: 12cm / 8cm
Video Decoding	: MPEG-2 / MPEG-1
Signal System	: PAL / NTSC
Video S/N	: 53 dB (min.)
Composite Video Output	: 1.0 Vp-p, 75
S-Video Output	: Y - 1.0 Vp-p, 75 C - 0.286 Vp-p, 75
Audio DAC	: 24 Bits / 96 kHz
Frequency Response	: 20 Hz - 20 kHz
Channel Unbalance	: < \pm 2dB
THD Noise	: 0.5%
No. of programmable tracks	: 20
Signal-to-noise ratio	: 70 dBA
Channel separation	: 40 dB (1 kHz) : 35 dB (16 kHz) : 30 dB (20 kHz)
Total harmonic distortion	: < 0.02% (1 kHz)

SERVICE TOOLS

Audio signal disc SBC 429.....	4822 397 30184
Playability test disc SBC 444.....	4822 397 30245
Test disc 5 (disc without errors) +	
Test disc 5A (disc with dropout errors, black spots and fingerprints)	
SBC 426/426A.....	4822 397 30096
Burn in test disc (65 min. 1kHz signal at -30 dB level without "pause").....	4822 397 30155

AVAILABLE ESD PROTECTION EQUIPMENT

anti-static table mat large 1200x650x1.25mm	4822 466 10953
small 600x650x1.25m	4822 466 10958
anti-static wristband	4822 395 10223
connection box (3 press stud connections, 1M Ω)	4822 320 11307
extendible cable (2m, 2M Ω , to connect wristband to connection box)	4822 320 11305
connecting cable (3m, 2M Ω , to connect table mat to connection box)	4822 320 11306
earth cable (1M Ω , to connect any product to mat or to connection box)	4822 320 11308
KIT ESD3 (combining all 6 prior products - small table mat)	4822 310 10671
wristband tester	4822 344 13999

SERVICE MEASUREMENT

Tuner SW

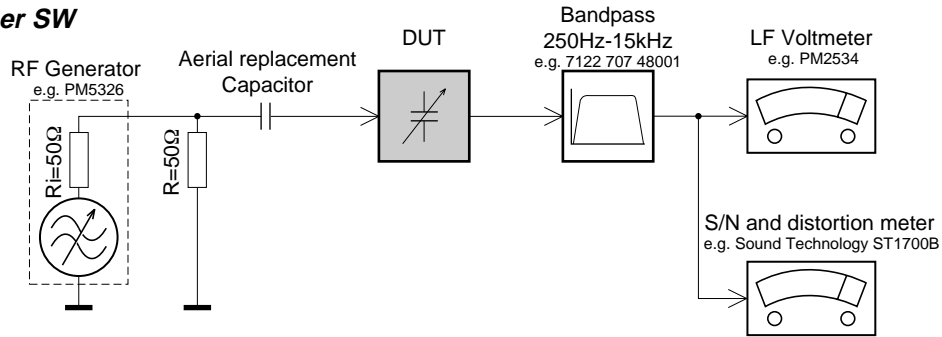

To avoid atmospheric interference all AM-measurements have to be carried out in a Faraday's cage. Use a bandpass filter (or at least a high pass filter with 250Hz) to eliminate hum (50Hz, 100Hz).

Tuner AM (MW,LW)

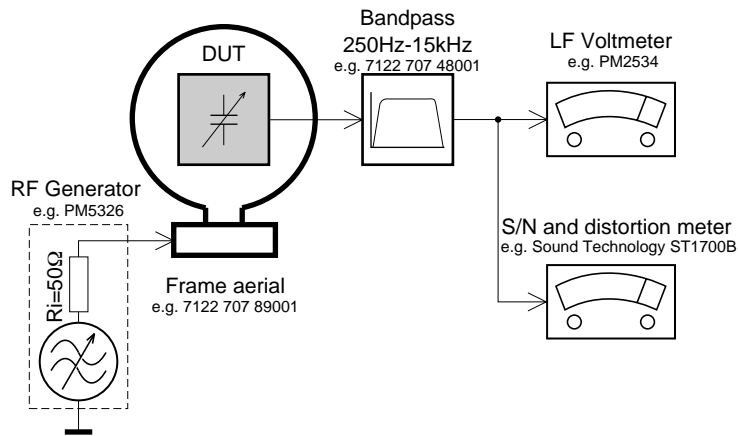

To avoid atmospheric interference all AM-measurements have to be carried out in a Faraday's cage.

CD

Use Audio Signal Disc SBC429 4822 397 30184 (replaces test disc 3)
L.P.F. = 13th order filter 4822 395 30204

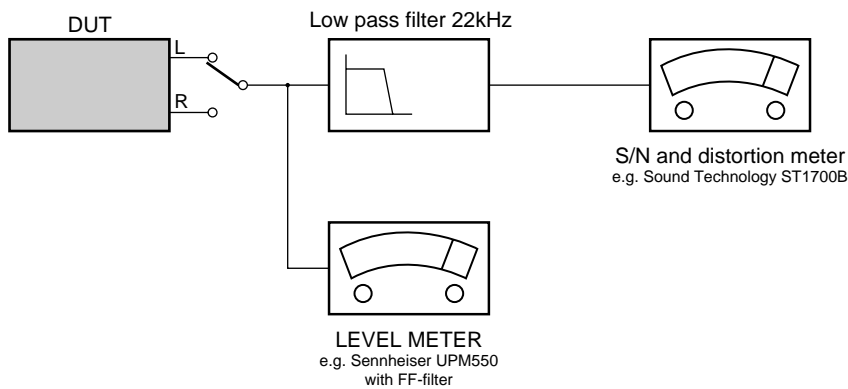

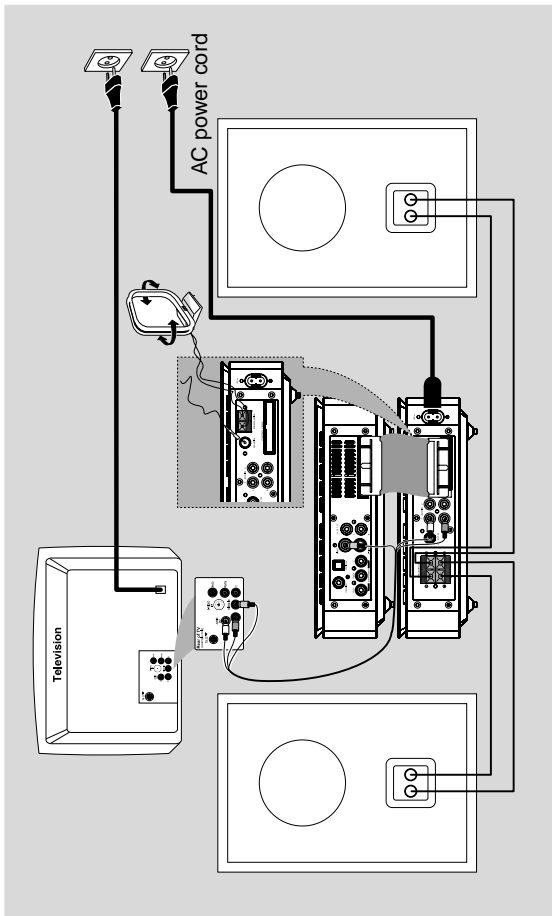

- IMPORTANT!**
- The type plate is located at the bottom of the system.
 - Before connecting the AC power cord to the wall outlet, ensure that all other connections have been made.
 - Never make or change any connections with the power switched on.

Step 1: Placing speakers

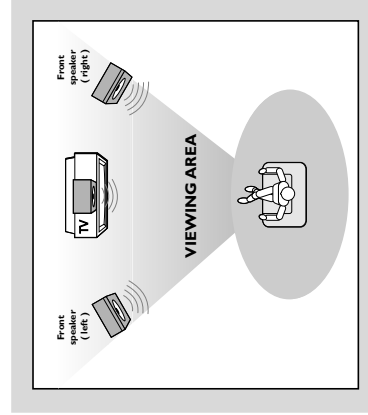

Step 2: Connecting speakers

Connect the speaker wires to the SPEAKERS terminals, right speaker to "R" and left speaker to "L", coloured (marked) wire to "+" and black (unmarked) wire to "-". Fully insert the stripped portion of the speaker wire into the terminal as shown.

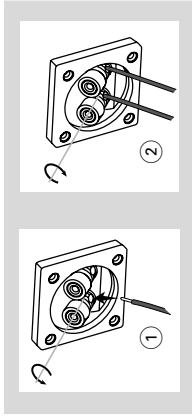

- Notes:**
- Ensure that the speaker cables are correctly connected. Improper connections may damage the system due to short-circuit.
 - For optimal sound performance, use the supplied speakers.
 - Do not connect more than one speaker to any one pair of +/- speaker jacks.
 - Do not connect speakers with an impedance lower than the speakers supplied. Please refer to the SPECIFICATIONS section of this manual.

Step 3: Connecting the control cable

Connect the serial port marked "CONTROL CABLE" at the rear of the DVD player to the same port at the rear of the power amplifier with the supplied flat control cable.

Step 4: Connecting TV

IMPORTANT!

- You only need to make one video connection from the following options, depending on the capabilities of your TV.
- Connect the DVD system directly to the TV.

Using Composite Video Jack

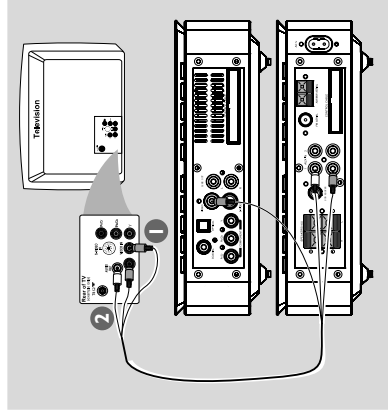

Use the composite video connectors (yellow) of the supplied audio and composite video cables (2-in1) to connect the DVD system's VIDEO OUT jack to the video input jack (or labeled as A/V In, CVBS, Composite or Baseband) on the TV.

To hear the TV channels through this DVD system, use the audio connectors (white/ red) of the supplied audio and composite video cables (2-in1) to connect AUDIO IN jacks to the corresponding AUDIO OUT jacks on the TV.

CONNECTION AND CONTROLS

Connections

Using Component Video jacks (Y Pb Pr)

IMPORTANT!

- The progressive scan video quality is only possible when using Y Pb Pr, and a progressive scan TV is required.

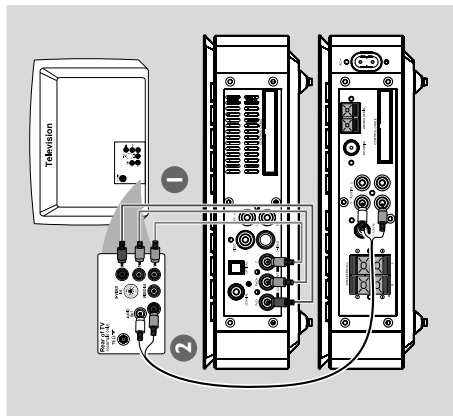

Use component video cables (red/blue/green - not supplied) to connect the DVD system's Y Pb Pr jacks to the corresponding Component video input jacks (or labeled as Y Pb/Cb Pr/Cr or UV) on the TV.

To hear the TV channels through this DVD system, use the audio cables (white/red) to connect AUDIO IN-TV jacks to the corresponding AUDIO OUT jacks on the TV.

If you are using a Progressive Scan TV (TV must indicate Progressive Scan or ProScan capability), to activate TV Progressive Scan, please refer to your TV user manual. For DVD system Progressive Scan function, see "Getting Started - Setting up Progressive Scan feature".

Note:

- If your TV does not support Progressive Scan, you will not be able to view the picture. Press **SYSTEM** on the remote to exit the system menu and then **DISC** to exit progressive scan.

Using S-Video jack

IMPORTANT!

- If S-Video is used for DVD playback connection, the system's VIDEO OUT setting will need to be changed accordingly.

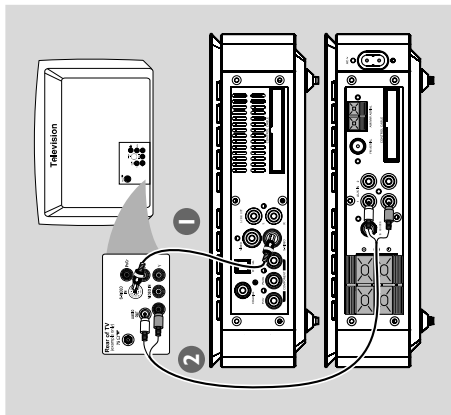

Use an S-Video cable (not supplied) to connect the DVD system's S-VIDEO jack to the S-Video input jack (or labeled as Y/C or S-VHS) on the TV.

To hear the TV channels through this DVD system, use the audio cables (white/red) to connect AUDIO IN-TV jacks to the corresponding AUDIO OUT jacks on the TV.

Using an accessory RF modulator

IMPORTANT!

- If your TV only has a single Antenna In jack (labeled as 75 ohm or RF In), you will need an RF modulator in order to view DVD playback on the TV. See your electronics retailer or contact Philips for details on RF modulator availability and operations.

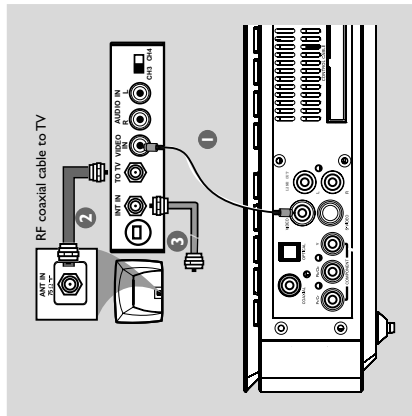

Use the composite video cable (yellow) to connect the DVD system's VIDEO OUT jack to the video input jack on the RF modulator.

Use an RF coaxial cable (not supplied) to connect ANTENNA OUT or TO TV jack on the RF modulator to the Antenna IN jack on the TV. Connect the Antenna or Cable TV service signal to the ANTENNA IN or RF IN jack on the RF modulator. (It may have been connected to your TV previously. Disconnect it from the TV.)

Connections

Step 5: Connecting FM/MW antennas

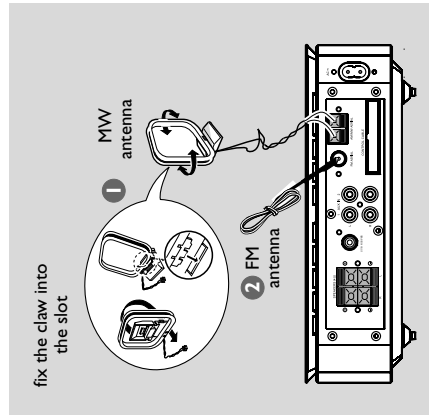

fix the claw into the slot

Connect the supplied MW loop antenna to the MW jack. Place the MW loop antenna on a shelf or attach to a stand or wall.
Connect the supplied FM antenna to the FM (75 ohm) jack. Extend the FM antenna and fix its end to the wall.

For better FM stereo reception, connect an external FM antenna (not supplied).

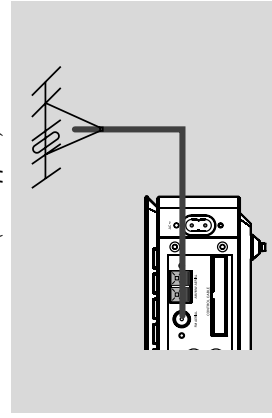

Note:

- Adjust the position of the antennas for optimal reception.
- Position the antennas as far as possible from your TV/VCR or other radiation source to prevent unwanted interference.

Step 6: Connecting the power cord

After everything is connected properly, plug in the AC power cord to the power outlet.

Never make or change any connection with the power switched on.

Additional: Connecting additional equipment

IMPORTANT!

- Some discs are copy-protected. You cannot record the disc through a VCR or digital recording device.
- When making connections, make sure the colour of cables matches the colour of jacks.
- Always refer to the owner's manual of the other equipment for complete connection and usage details.

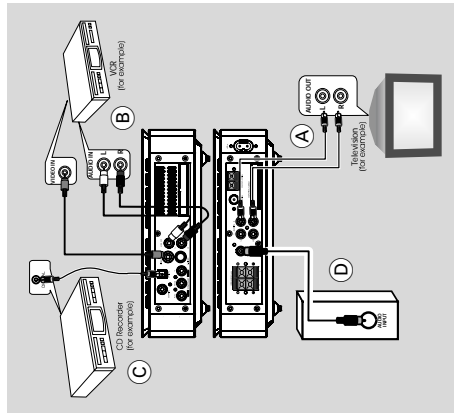

Viewing and listening to the playback of other equipment (A)

Connect the system's **AUX IN (R/L)** jacks to the **AUDIO OUT** jacks on the other audio/visual device (such as a TV, VCR, Laser Disc player or cassette deck). Before starting operation, press **SOURCE** on the front panel to select **AUX** or press **AUX** on the remote in order to activate the input source.

Using the VCR for recording DVDs (B)
Connect one of the system's **VIDEO** jacks to the corresponding **VIDEO IN** jack and **LINE OUT (R/L)** jacks to the **AUDIO IN** jacks on the VCR. This will allow you to make analogue stereo (two channel, right and left) recordings.

Recording (digital) (C)
Connect the system's **COAXIAL** or **OPTICAL** jack to the **DIGITAL IN** jack on a digital recording device (such as DTS-Digital Theatre compatible, with Dolby Digital decoder).

Before starting operation, set the **DIGITAL OUT** according to the audio connection. (See "DIGITAL OUT".)

Connecting an active subwoofer (D)
Connect the DVD micro system's **SUBWOOFER** jack to the **AUDIO INPUT** jack on an active subwoofer (not supplied).

Functional Overview

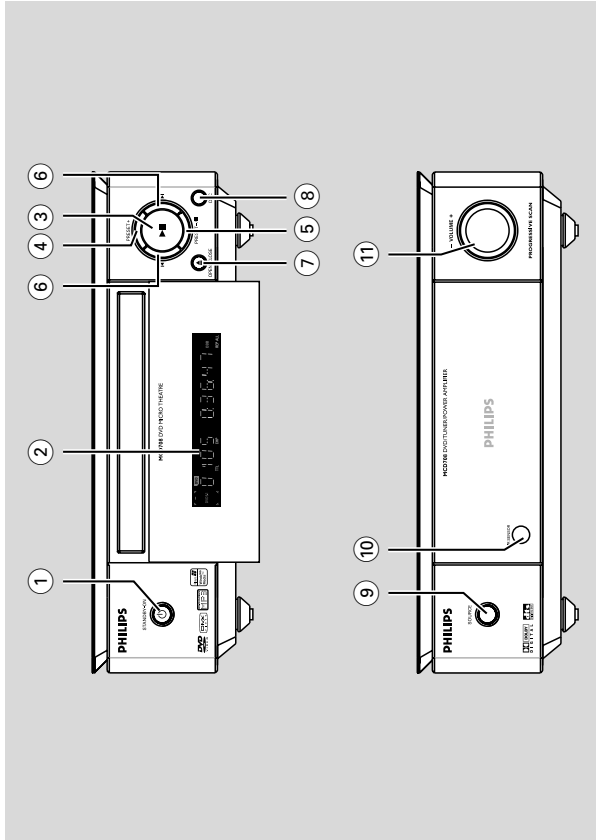

DVD player and power amplifier

- 1 STANDBY-ON**
 - switches the system on or to standby mode
- 2 Display**
 - shows the current status of the DVD player.
- 3**
 - starts or interrupts disc playback.
- 4 PRESET +**
 - in tuner mode, selects a preset radio station forward.
- 5 PRESET -**
 - stops disc playback or eases a program.
 - in tuner mode, selects a preset radio station backward.
- 6**
 - Disc: skips to the previous/next chapter/title/track.
 - Tuner: tunes to a higher/lower radio frequency press and hold, then release the key to start automatic search for a radio frequency downward/upward.
- 7 OPEN-CLOSE**
 - opens or closes the disc tray.
- 8 DSC**
 - selects different types of preset sound equalizer settings (FLAT, POPS, JAZZ, CLASSIC or ROCK).
- 9 SOURCE**
 - selects the respective sound source: DVD/AUX1/AUX2/FM/MW.
 - switches the system on.
- 10 IR SENSOR**
 - point the remote control towards this sensor
- 11 VOLUME +/-**
 - adjusts the volume upward/downward.
 - adjusts the hours and minutes in clock/timer setting mode.
 - switches the set timer ON or OFF.

CONNECTION AND CONTROLS

Functional Overview

- ⑫ **TU +/- (◀ / ▶)**
Tuner
- press to tune to a lower/higher radio frequency gradually.
- press and hold, then release the key to start automatic search for a radio frequency downward/upward.
- ⑬ **VOLUME +/-**
- adjusts the volume upward/downward.
- adjusts the hours and minutes in clock/timer setting mode.
- switches the set timer ON or OFF.
- ⑭ **CH +/- (◀ / ▶)**
Disc: skips to the previous/hext chapter/title/ track
Tuner: selects a preset radio station.
- ⑮ **▶ ||**
- starts or interrupts disc playback.
- ⑯ **■**
- stops disc playback or erases a program.
- ⑰ **DISC/TUNER/AUX**
- selects the respective sound source for DVD/AUX1/AUX2/FM/MW.
- For tuner (**TUNER**): press to switch between MW and FM
- exits P-SCAN (progressive scan). (Only for **DISC**)
- ⑱ **SLEEP/TIMER**
Standby mode
- sets time for switching on the system automatically
Power-on mode
- sets the sleep timer function (auto off)
- ⑲ **CLOCK**
Standby mode
- sets the system clock.
Playback mode
- displays the system clock.
- ⑲ **DIM**
- selects different levels of brightness for the display screen.
- ⑲ **SUBTITLE**
- selects a subtitle language
- ⑲ **ANGLE**
- selects a DVD camera angle.
- ⑲ **DISPLAY**
- displays information on TV screen during playback
- AUDIO**
for VCD/DivX
- sets Stereo/Mono-Left or Mono-Right sound mode.
- A-B**
- repeats playback of a specific section on a disc
- ⑲ **MODE**
- selects various repeat modes or the shuffle play mode for a disc
- SLOW**
- selects different slow playback modes for a DivX/VCD/SVCD/DVD.
- ⑲ **DBB**
- enables or disables bass enhancement.
- ⑲ **SURROUND (unavailable for this version)**
- selects 2.1 channel output (2.1CH) or 5.1 channel output (SUR5.1 orDVD5.1).
- ⑲ **VOL-SEL (unavailable for this version)**
- adjusts volume level for individual speakers.
- ⑲ **DSC**
- selects different types of preset sound equalizer settings (FLAT, POPS, JAZZ, CLASSIC or ROCK)
- ⑲ **LOUDNESS**
- enables or disables automatic loudness adjustment.

- ④ **PROG**
DVD/VCD/CD: enters the program menu.
MP3/WMA-CD : adds/deletes a programmed track to/from the program list.
Picture CD: **during playback**, to select a slide show mode .
Tuner: programs preset radio stations.
- ⑤ **GOTO/ST**
Disc: fast searches in a disc by entering a time, title, chapter or track.
FM: sets stereo or mono sound mode .
- ⑥ **SYSTEM (disc mode only)**
- enters or exits the system menu.
- ⑦ **DISC MENU (disc mode only)**
DVD/VCD : enters or exits the disc contents menu.
VCD2.0: switches the playback control mode on or off .
MP3/WMA : switches between Album and Filelist.
- ⑧ **▼ / ▲ / ▶ / ◀**
- selects an item in a menu.
- moves an enlarged picture up/down/left/right.
- ⑨ **OK**
- confirms a selection.
- ⑩ **ZOOM**
DVD/VCD/Picture CD : enlarges or reduces a picture or active image on the TV screen.
- ⑪ **MUTE**
- disables or enables sound output.

Functional Overview

Remote control

- ① **⏻**
- switches the system on/off.
- ② **⏮**
- opens or closes the disc compartment
- ③ **Numeric Keypad (0-9)**
- inputs a track/title/chapter number of the disc .
- inputs the number of a preset radio station.

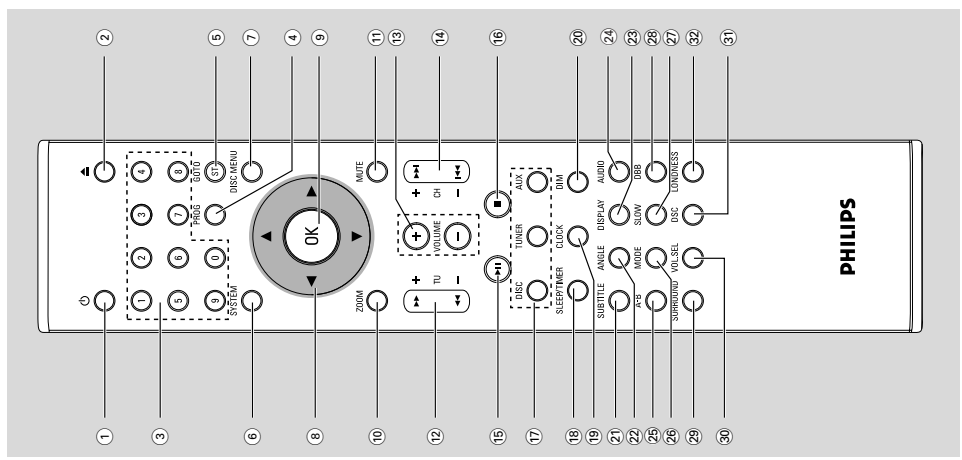

DISASSEMBLY DIAGRAM - DVD PART

A.Remove Bottom Cover

A1.remove screws M2.5x4(8pcs)

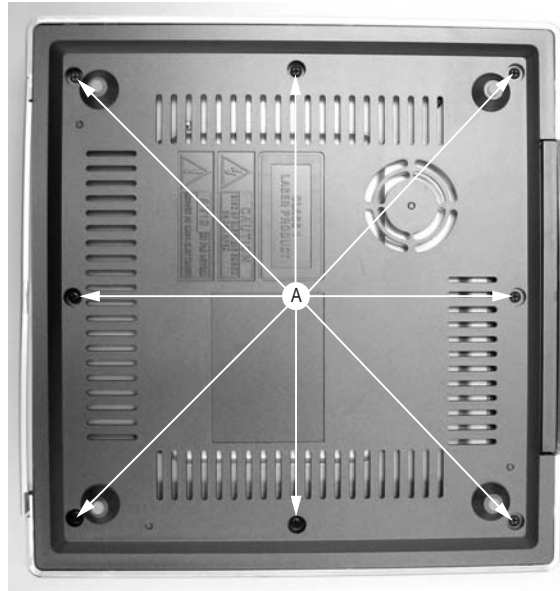

B*.remove screws M3x10(8pcs) and M3x8(3pcs)
C*.remove screws M3x8(4pcs) and T3x4(2pcs)

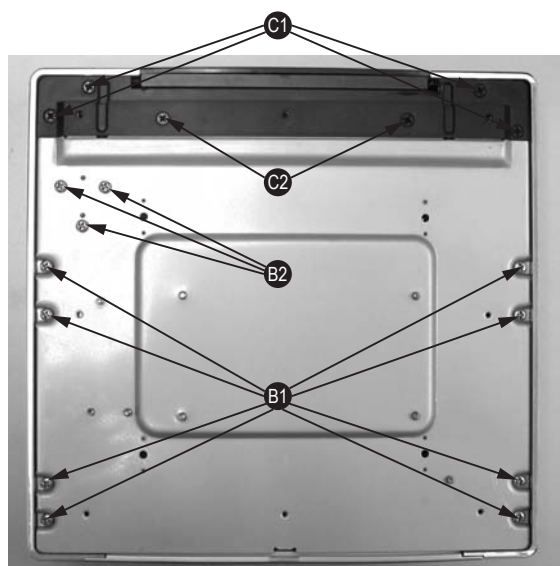

D.Remove Back Panel

D*remove screws T3x4(5pcs)and M3x10(5pcs)and T3x8(1pc)

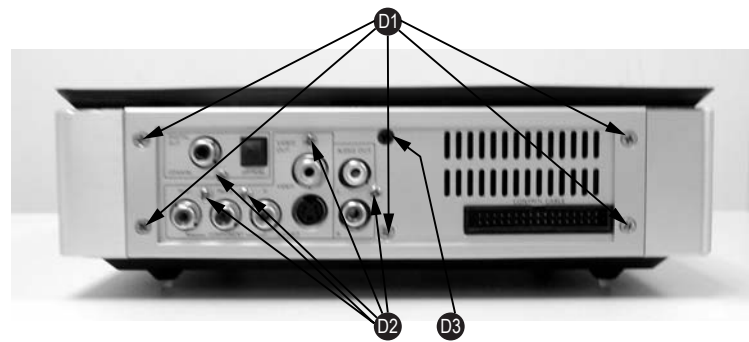

E. Remove Top Cover

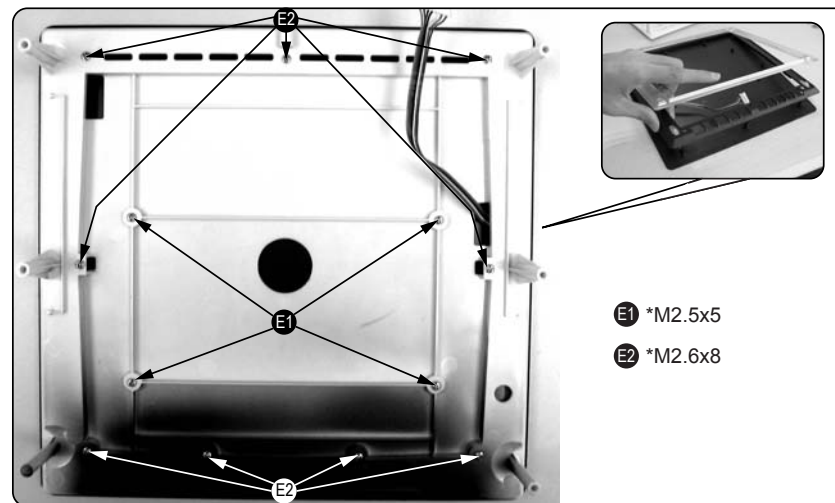

G. Remove DVD Rom and then remove DVD Decoder Card Assy

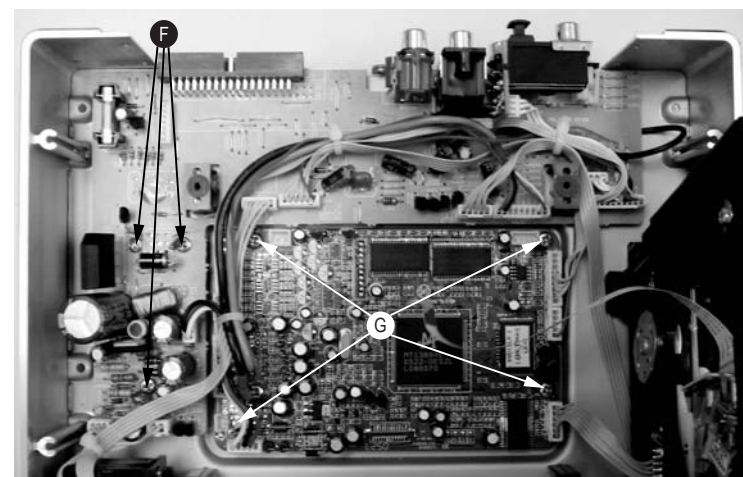

H.Remove Slid Plank

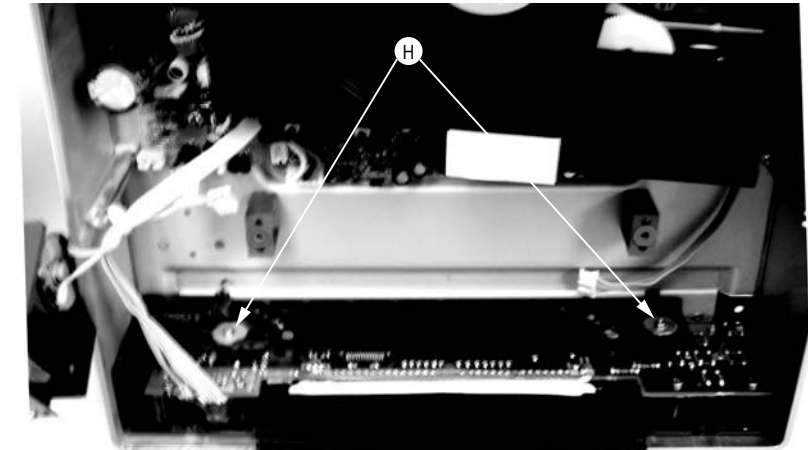

I.Remove VFD board assy

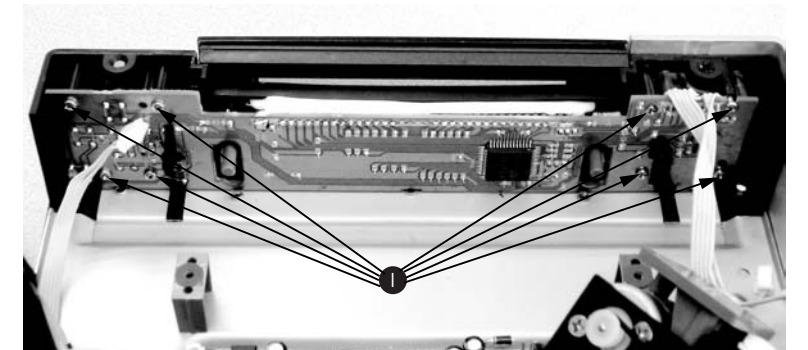

I.Remove Side metal Plate



DISASSEMBLY DIAGRAM - AMP PART

A.Remove Bottom Cover
A1.remove screws M2.5x4(8pcs)

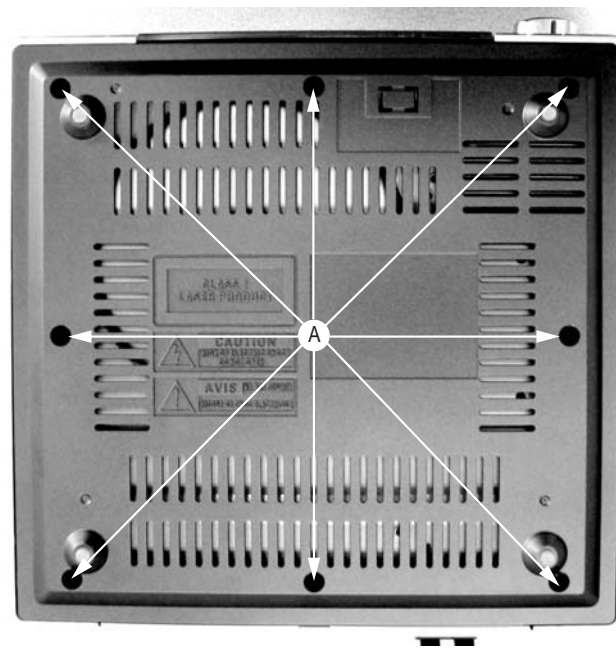

B*.remove screws M3x10(6pcs) and T3x10(4pcs)
C*.remove screws T3x4(5pcs)

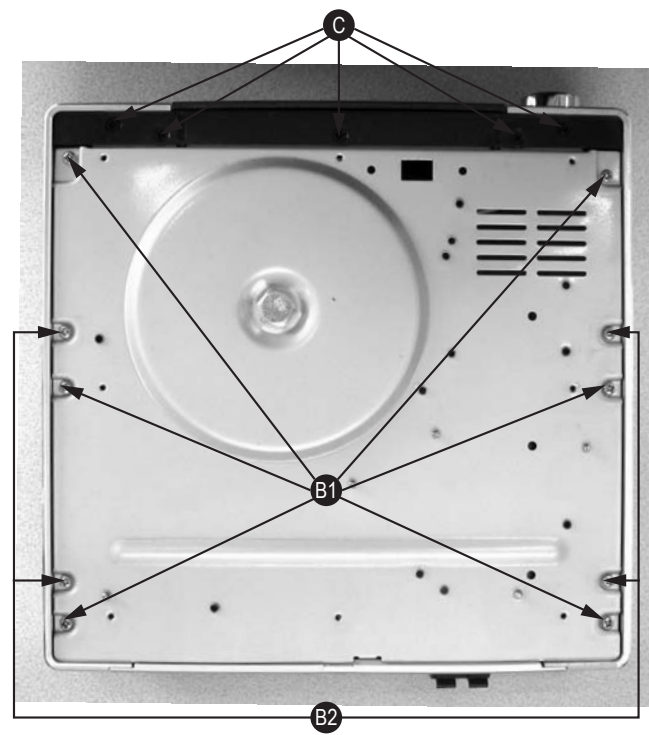

D.Remove Back Panel
D*remove screws T3x4(4pcs)and T3x8(2pcs)and M3x10(6pcs)

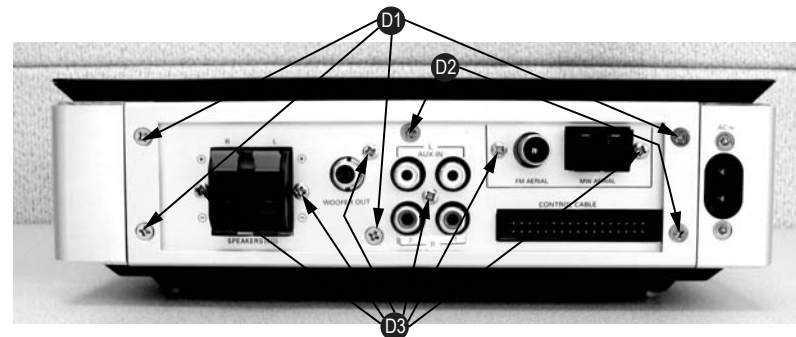

E. Remove Top Cover

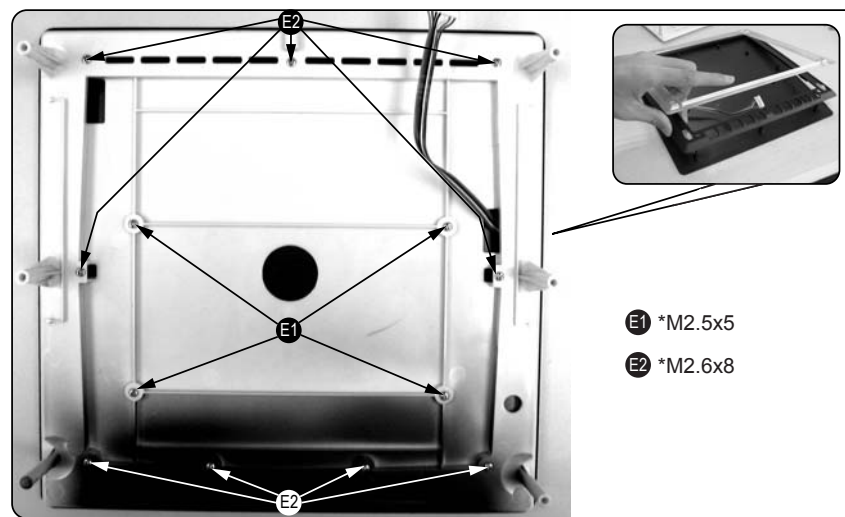

F. Remove AMP Board Assy

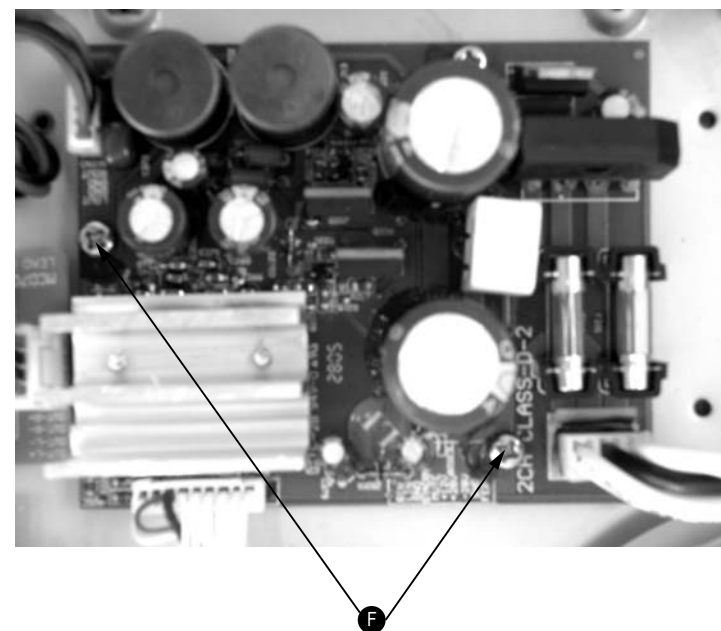

G.Remove ALC Volume board assy

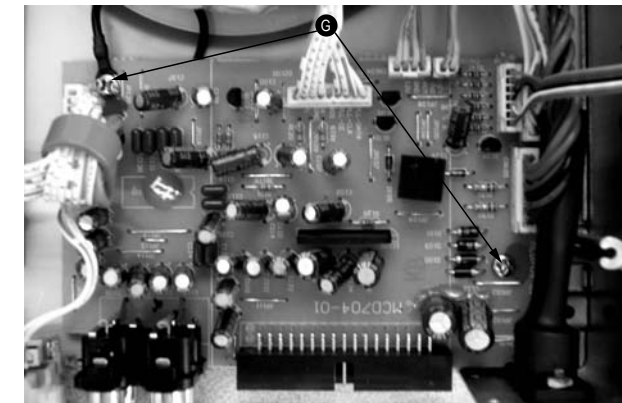

H.Remove AMP Front board assy

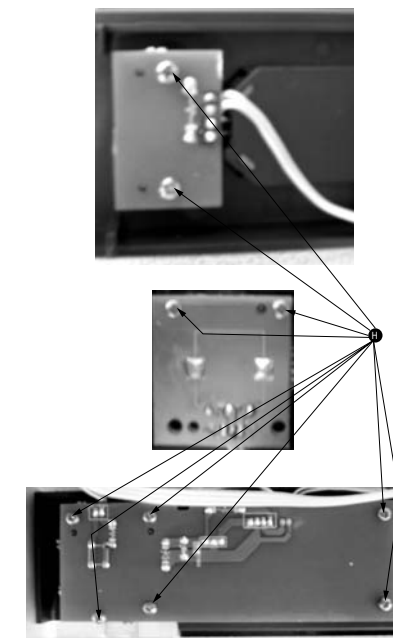

I.Remove Side metal Plate



SOFTWARE VERSION AND UPGRADING

A.MPEG SOFTWARE VERSION CHECK

1.Press SYSTEM key to open setup page,

TV Screen shows:

```

TV Displlay

Osd Lang
Screen Saver
DIVX(R) VOX
  
```

2.Press REMOVAL key to the original setup page,

TV Screen shows:

```

TV Type
Audio
Subtitle
Disc Menu
Parental
Default
  
```

3.Enter the password "811502"

TV Screen shows:

```

Ver      MCD708/xxxx
Date     mm dd yyyy
Time     hh:mm:ss
Region code  x
  
```

B.CPU VERSION CHECK

Keep PLAY/PAUSE and STOP buttons (on the set) depressed while pressing POWER on.

TV screen shows

```

MCD708 V xx
  
```

C. MPEG SOFTWARE UPGRADING

1. download the firmware from Philips support website
<http://www.philips.com/support>

2. Prepare a uploading CD

3. Put the CD in the CD tray

4. TV Screen shows

```

Upgade file deteced
Upgade?
Press PLAY to start
upgrading
  
```

SET BLOCK DIAGRAM

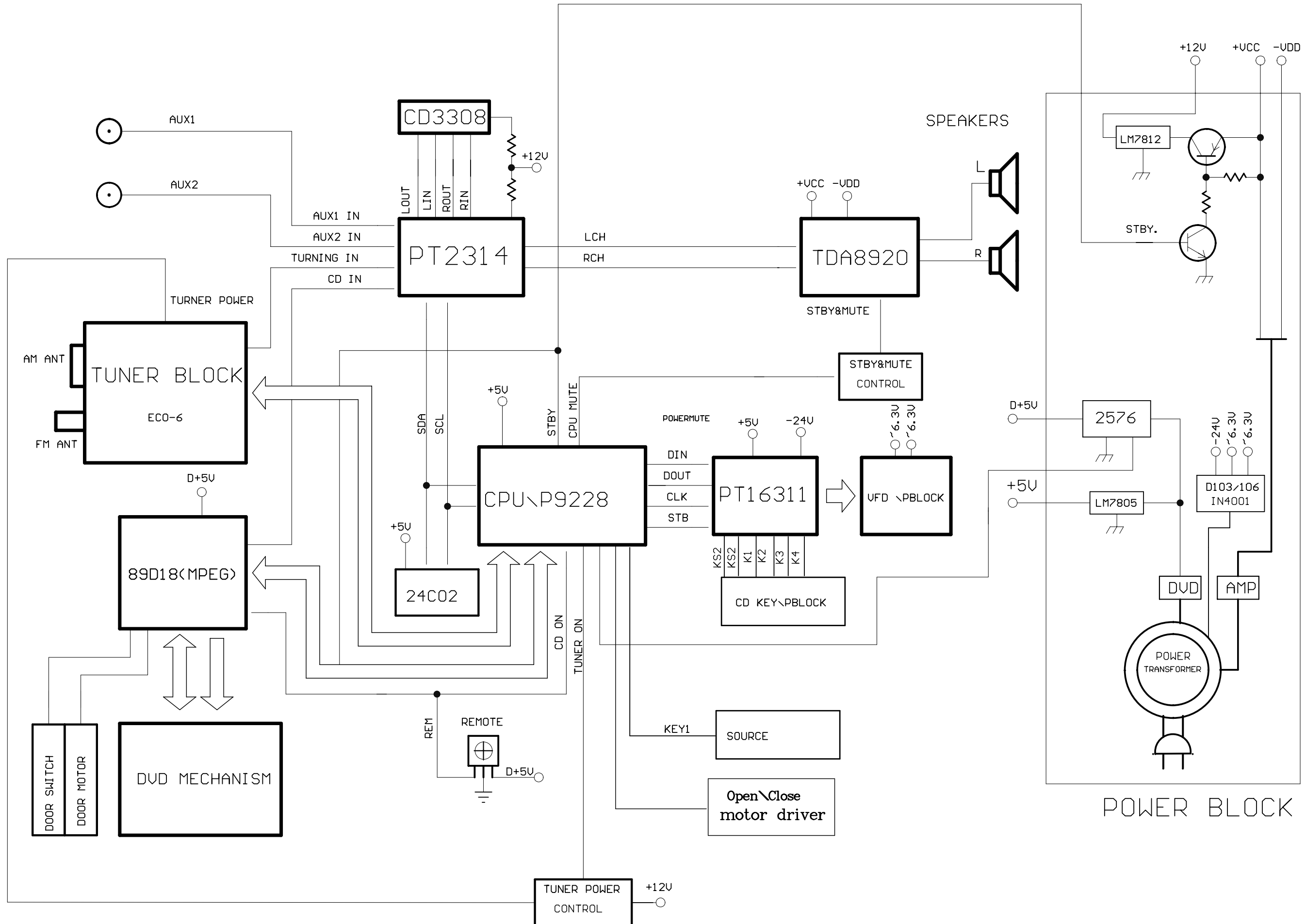

SET WIRING DIAGRAM

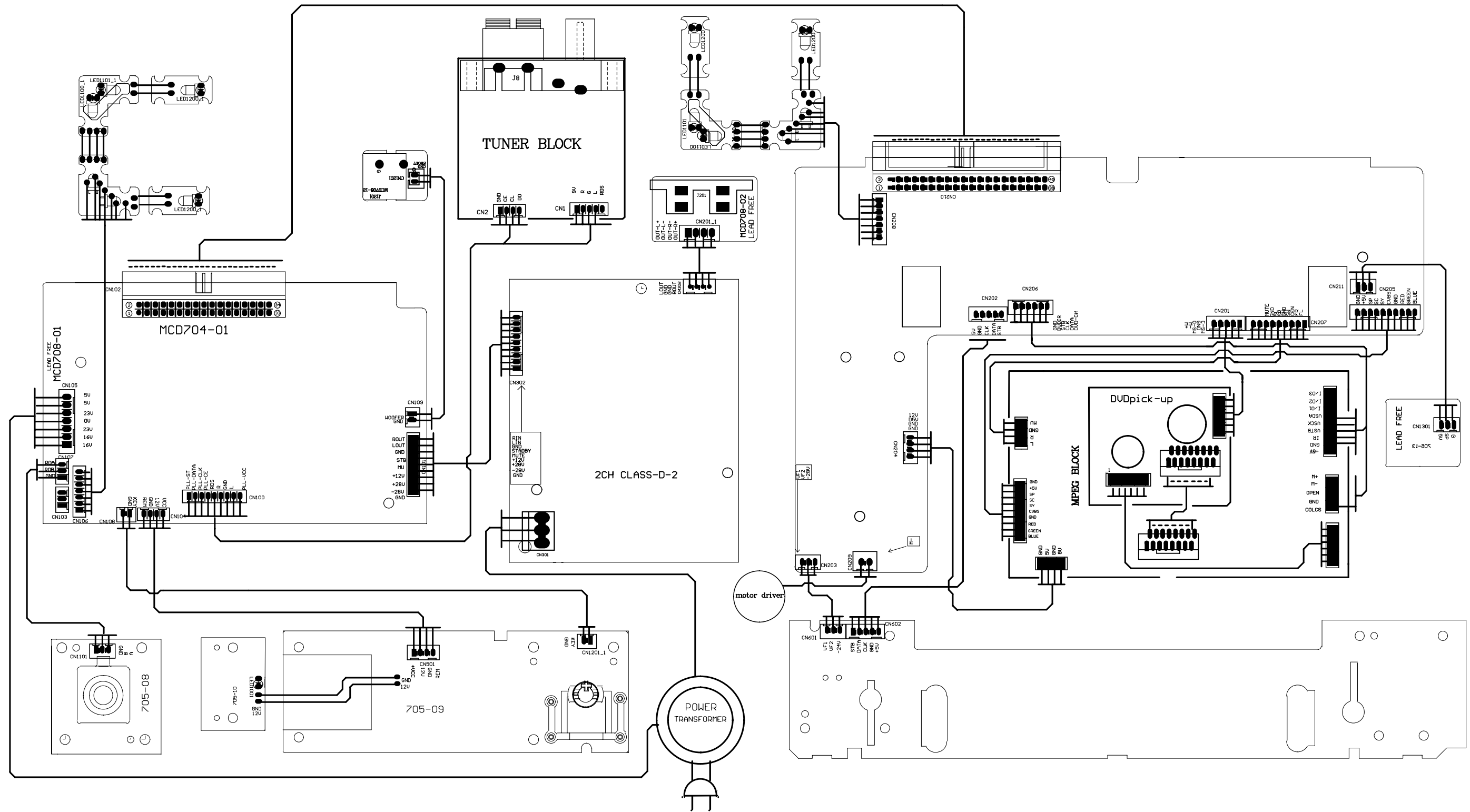

CIRCUIT DIAGRAM - VFD BOARD

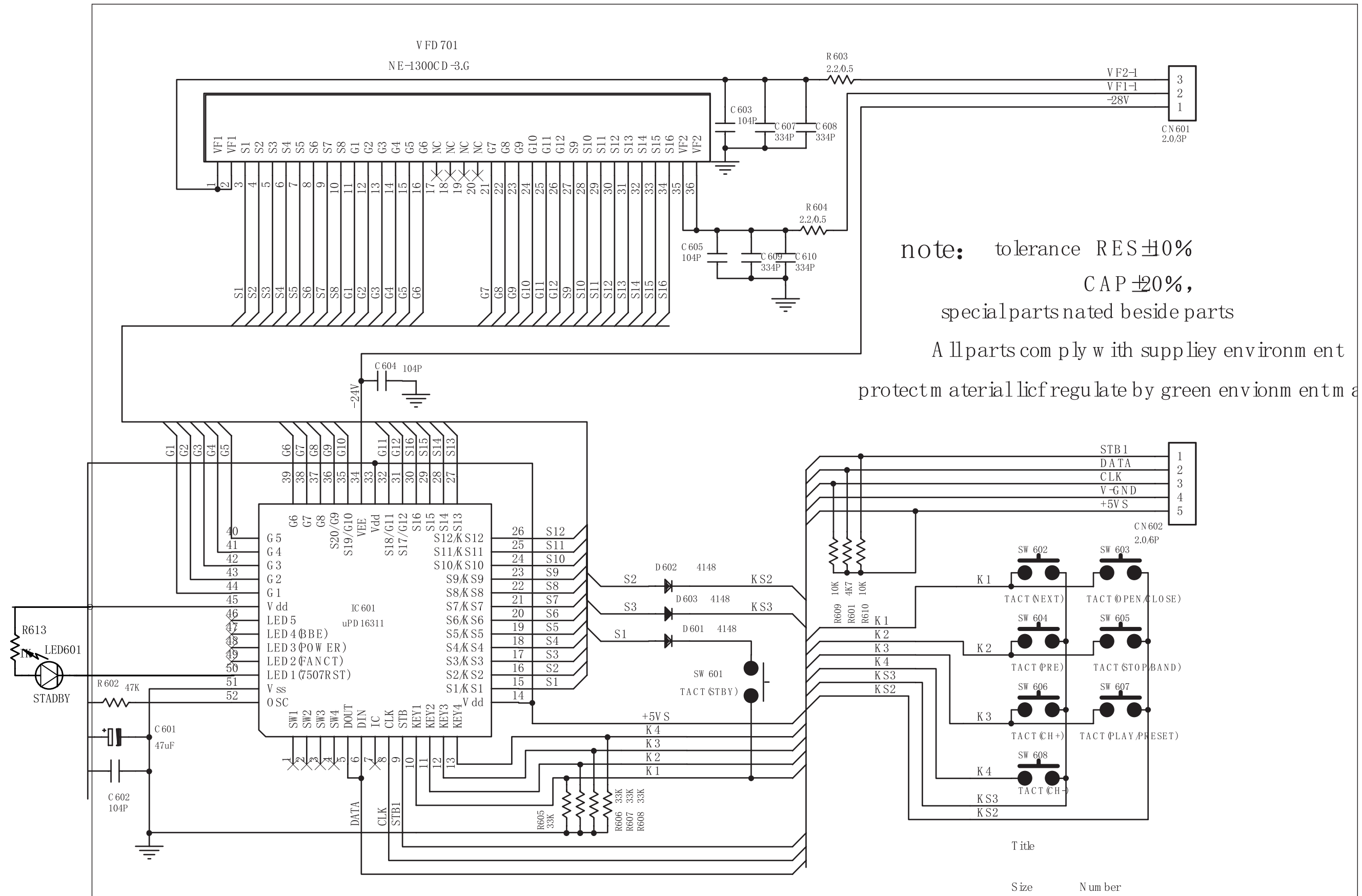

note: tolerance RES $\pm 0\%$
 CAP $\pm 20\%$,
 special parts nated beside parts
 All parts comply with supply environment
 protect material licf regulate by green envionm ent m a

Title
 Size Num ber

LAYOUT DIAGRAM - VFD BOARD

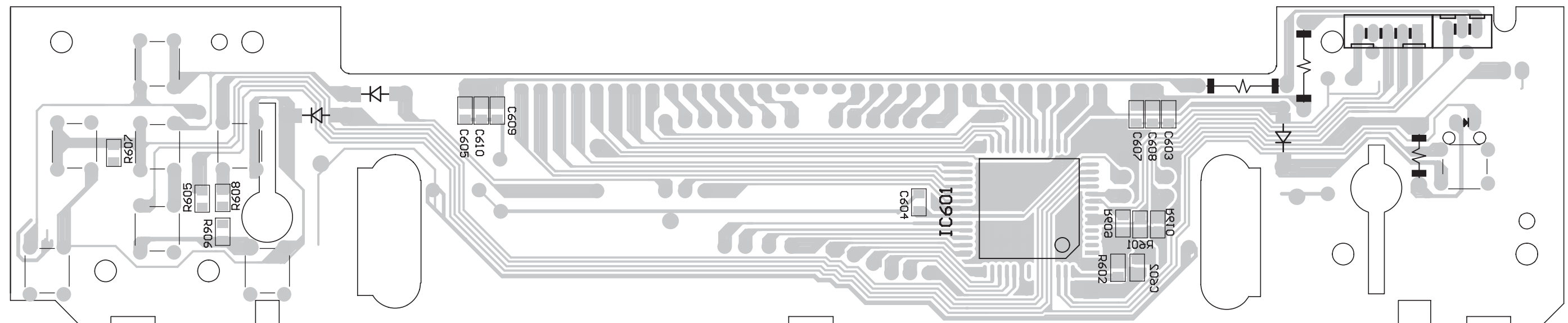
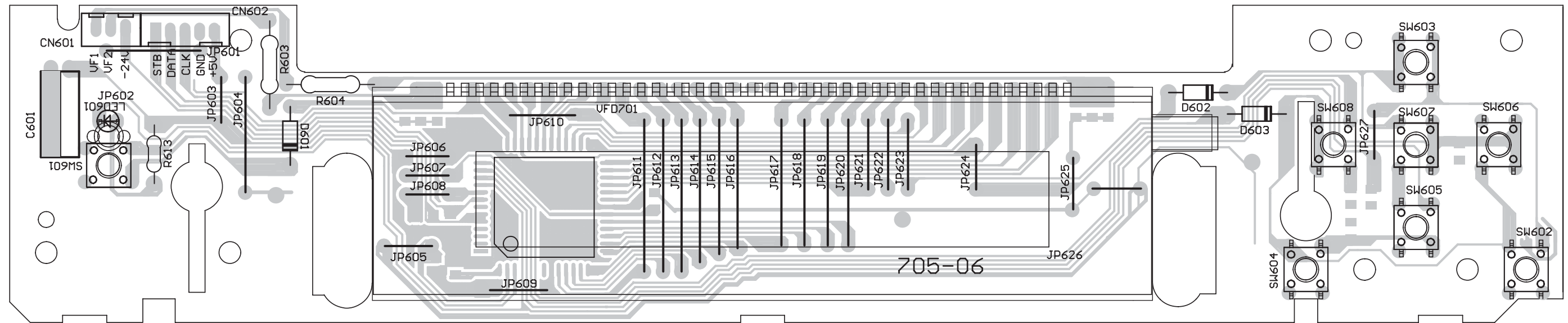

CIRCUIT DIAGRAM - TUNER BOARD

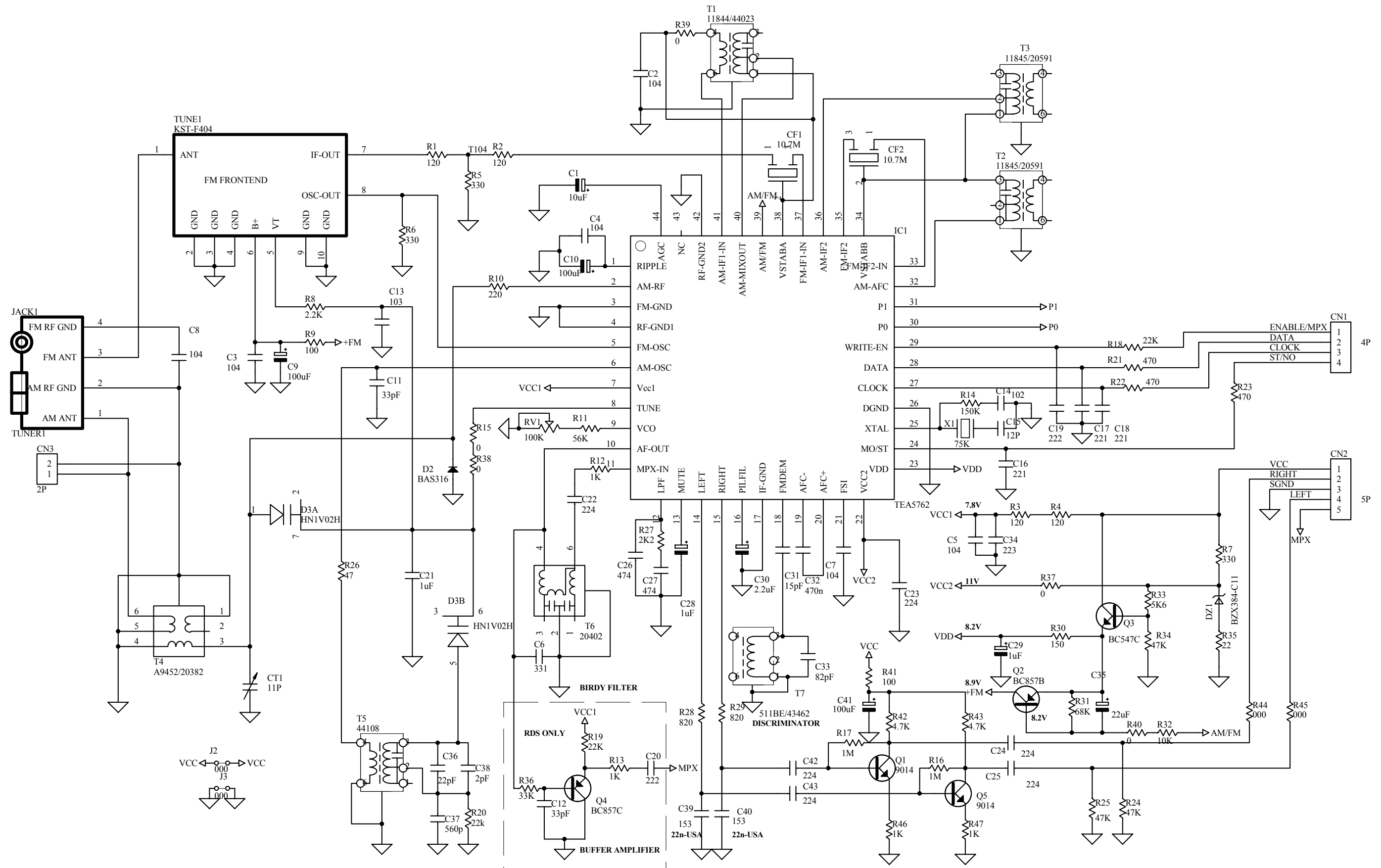

LAYOUT DIAGRAM - TUNER BOARD

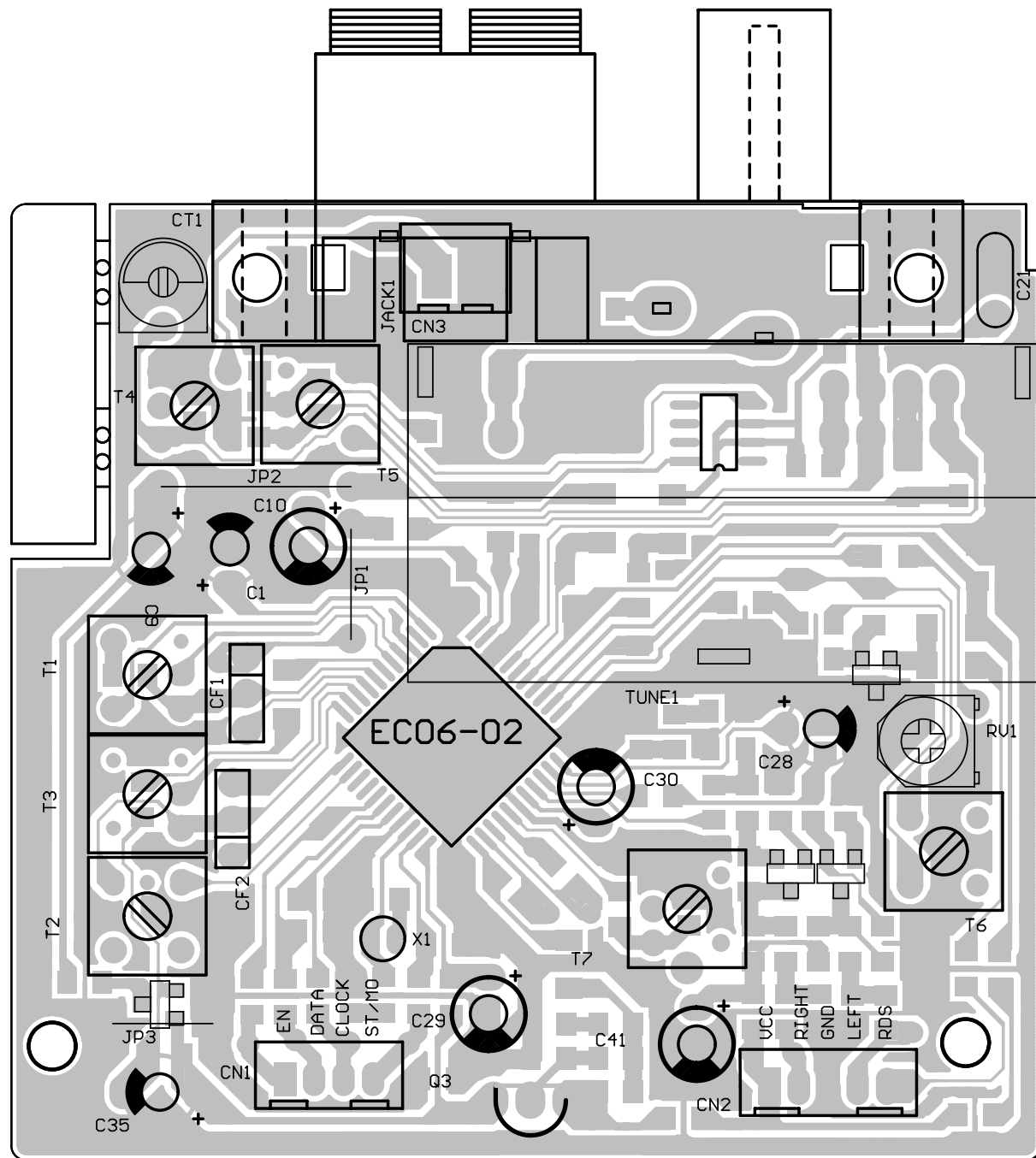

LAYOUT DIAGRAM -AMP BOX PCB ASSY

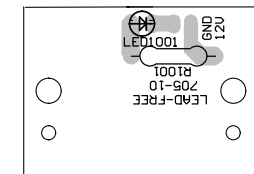
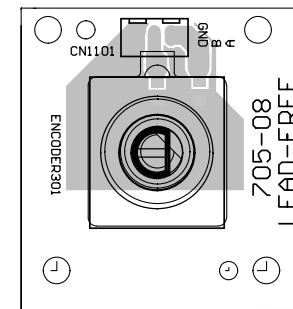
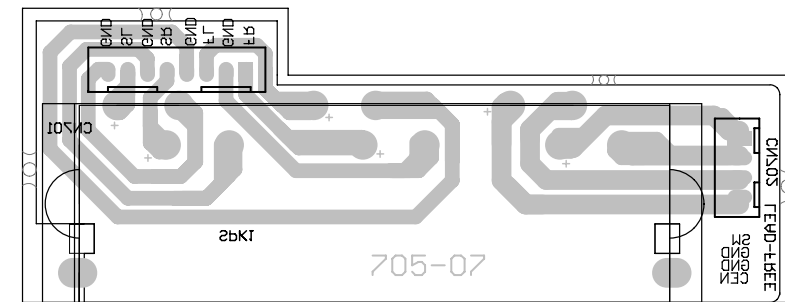
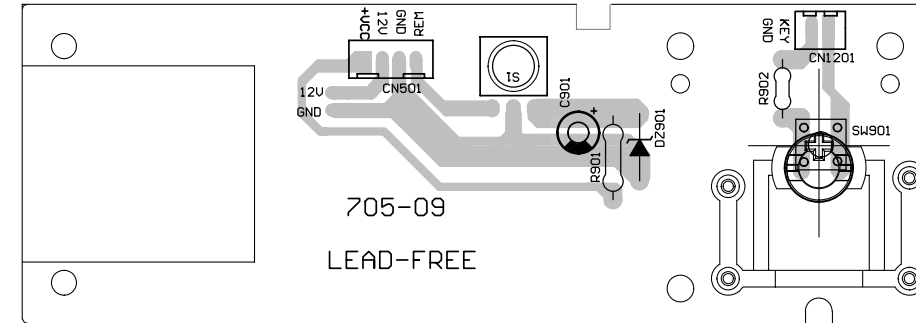

ONLY FOR -/12

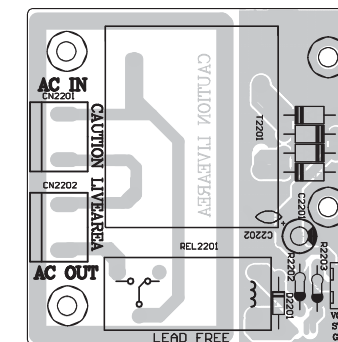

CIRCUIT DIAGRAM - CPU BOARD

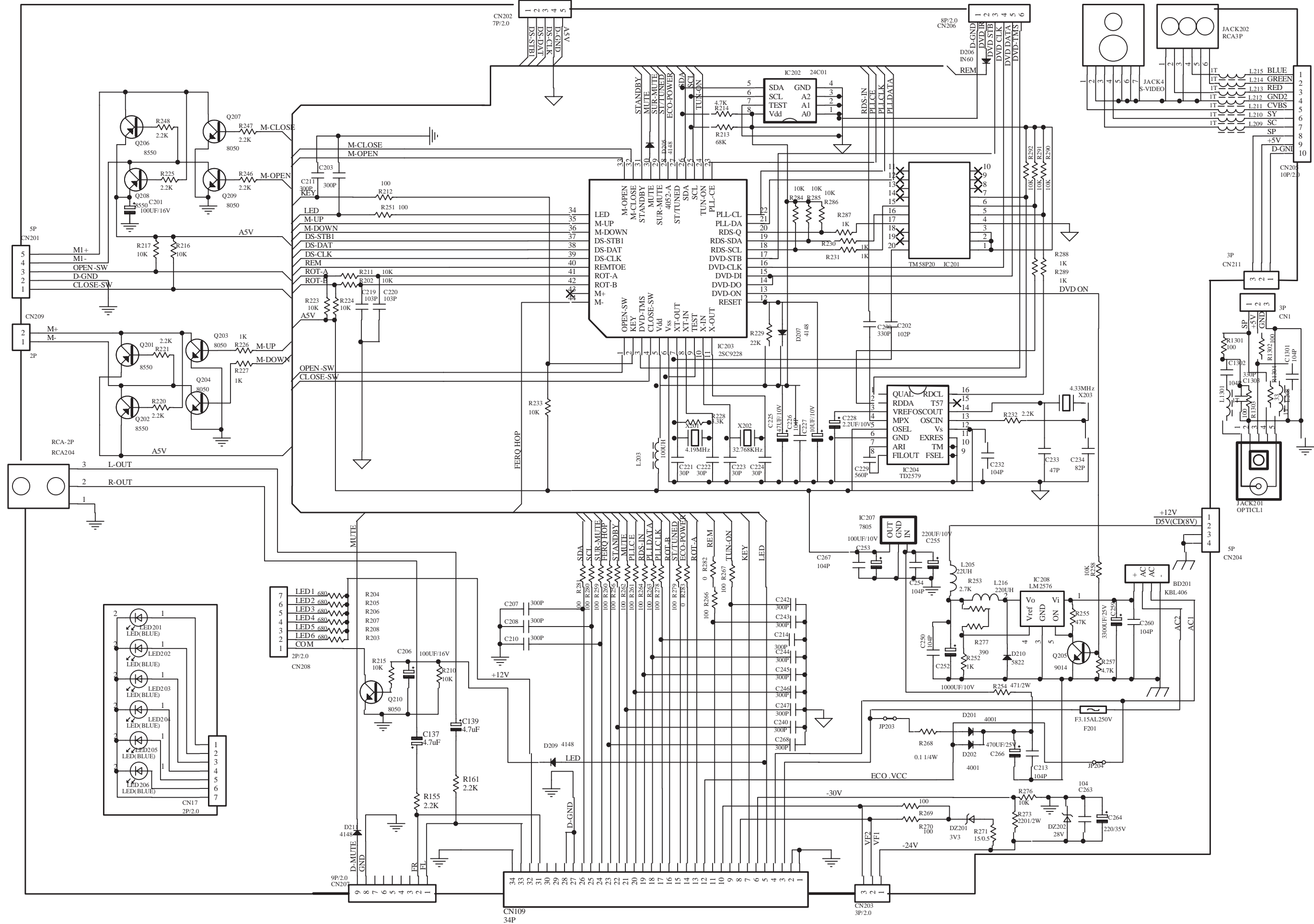

CIRCUIT DIAGRAM - ALC VOLUME BOARD

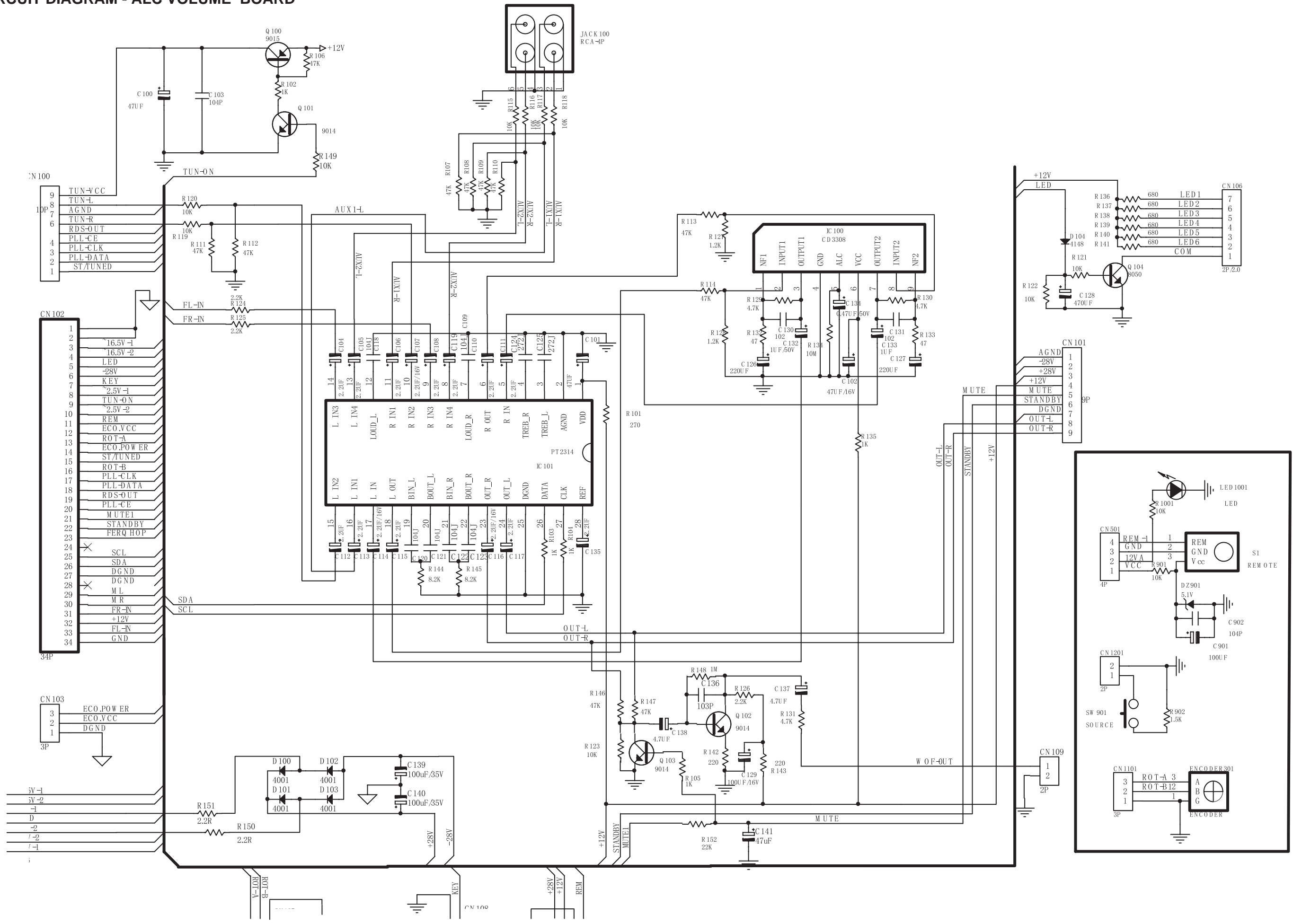

LAYOUT DIAGRAM - ALC VOLUME BOARD

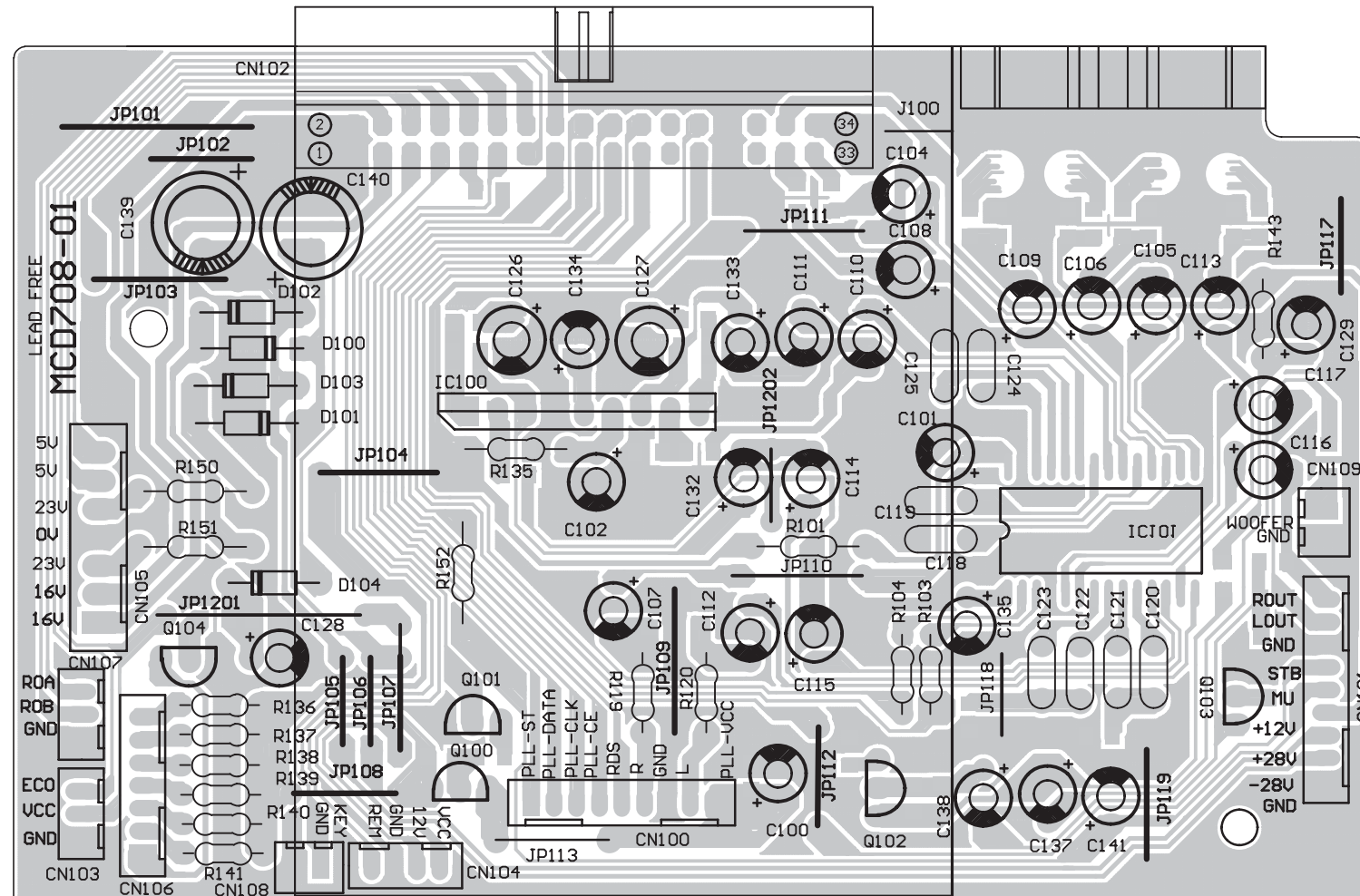
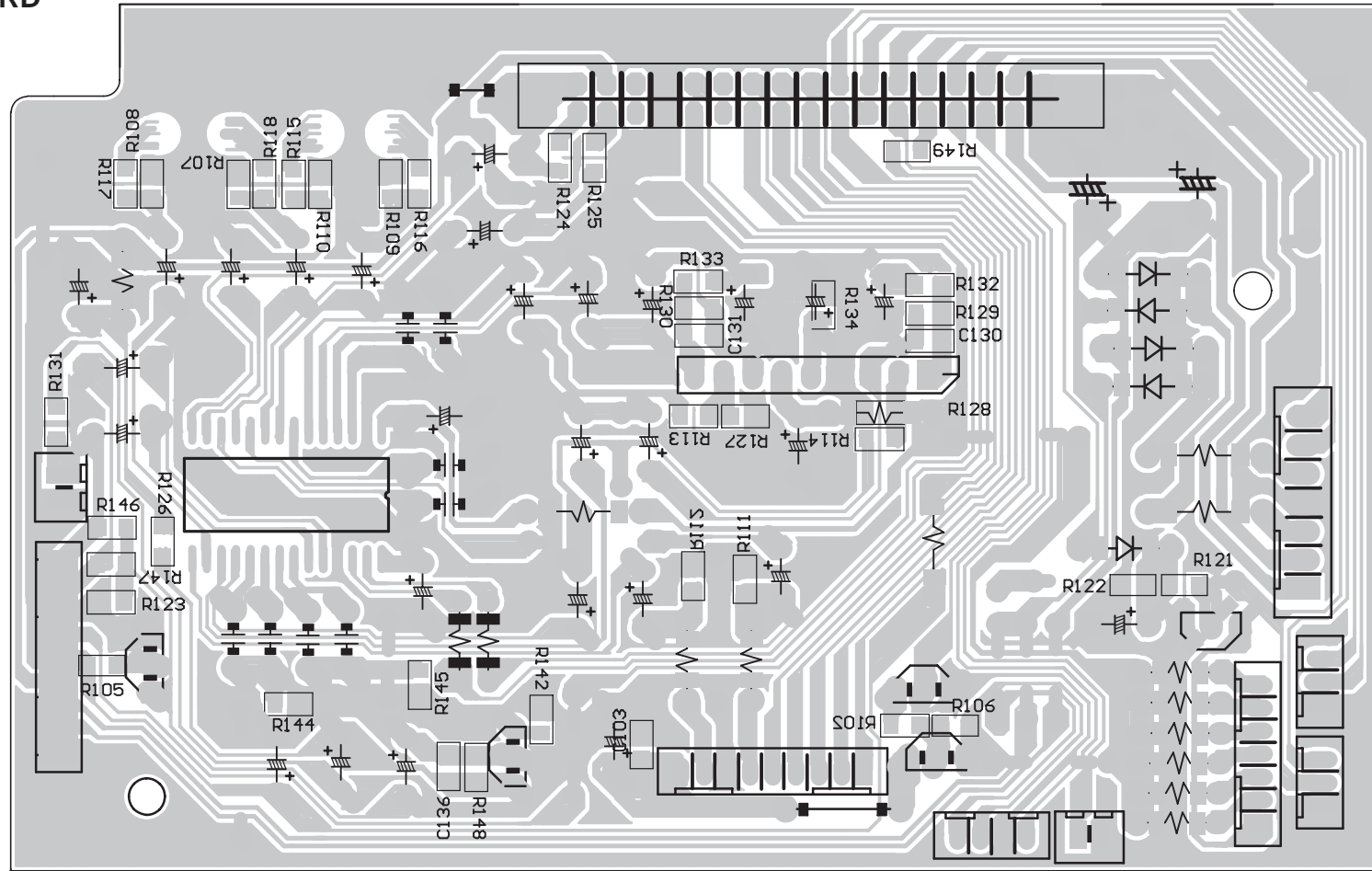

CIRCUIT DIAGRAM - DVD MPEG BOARD

MPEG board is not repaired, program for reference only.

- [1] +12V >> +12V
- [1] -12V >> -12V
- [1] +12V1 >> +12V1
- [1] DV33 >> DV33
- [1] VCC >> VCC
- [1] VCC_AUDIO >> VCC_AUDIO
- [1,2,3,5] GND >> GND
- [1] MIC1 >> MIC1
- [1,2] MIC_EN >> MIC_EN
- [2] ASPDIF >> ASPDIF
- [2] ASDAT0_2 >> ASDAT0_2
- [2] ACLK >> ACLK
- [2] ABCK >> ABCK
- [2] ALRCK >> ALRCK
- [2] MUTE_DAC >> MUTE_DAC
- [2] RESET# >> RESET#
- [4] ML >> ML
- [4] MR >> MR
- [2] DEMP >> DEMP
- [2] AMDAT >> AMDAT
- [2] REST_CS >> REST_CS
- [2] SCL >> SCL
- [2,3] SDA >> SDA
- [2] VSCK >> VSCK
- [2] VSDA >> VSDA
- [2] FAN >> FAN

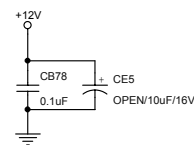
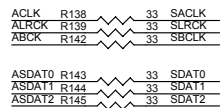
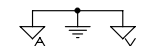
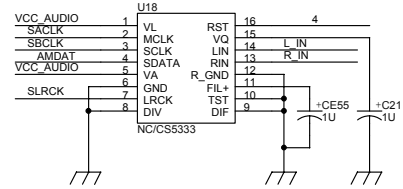

U10: WM8746 (U24)
 R126, R210, R145, R142, R204, R205, R206, R207, R208, CE71, CE46 (OPEN) R209=0, R129=10, R198=R199=33, CE40=100uF/10V
 R2: D/A DA1196/MM8746 (U24)
 R209, R142, R198, R199, R129, R207, R208, CE71, CE46 (OPEN), R128=10 R210=R145=R204=R205=R206=0, CE40=100uF/10V

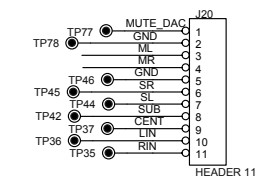
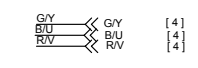
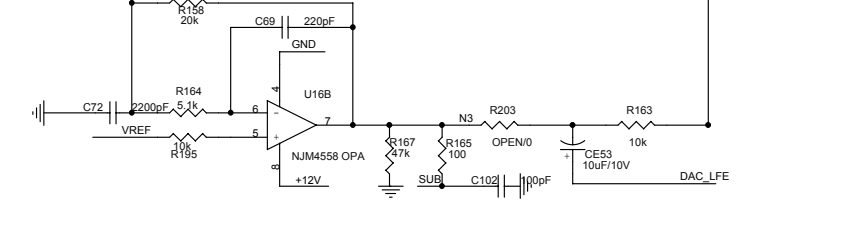
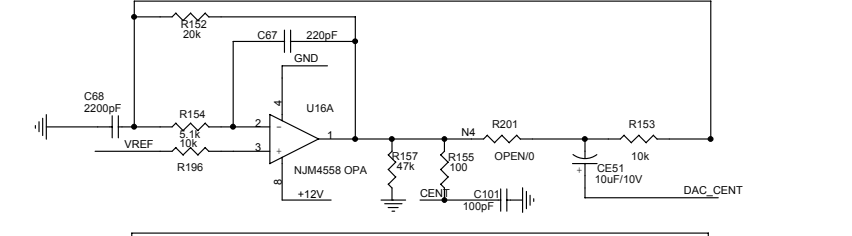
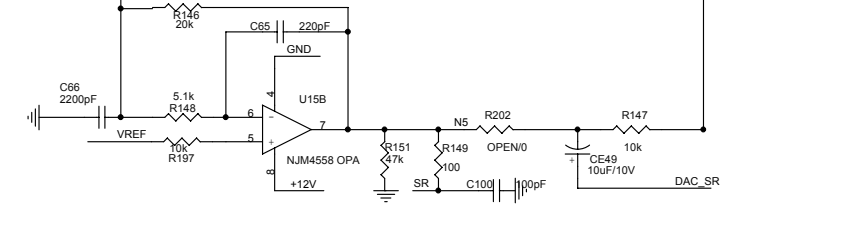
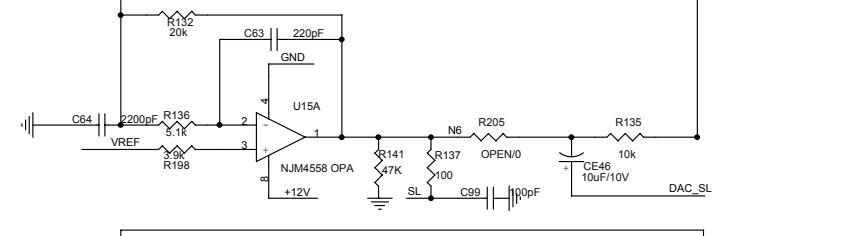
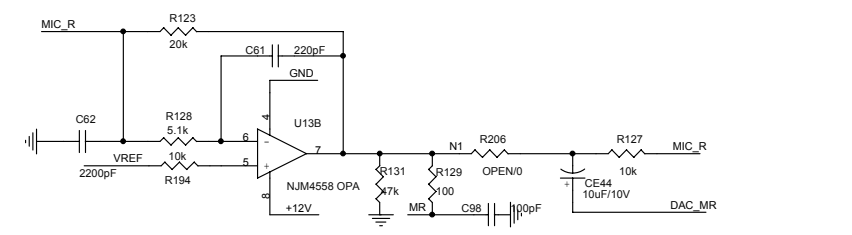
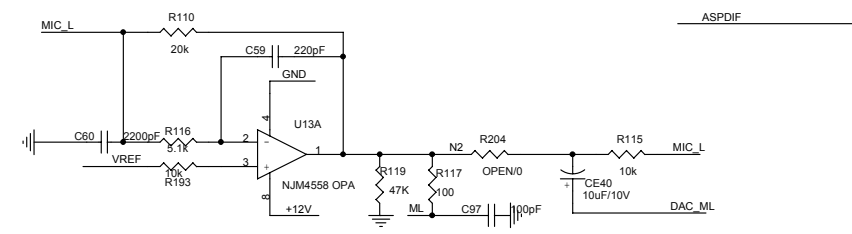
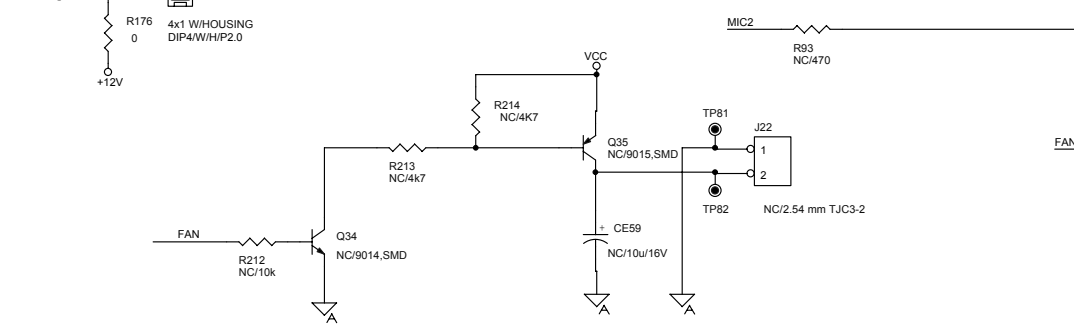
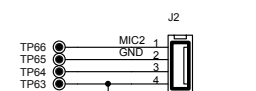
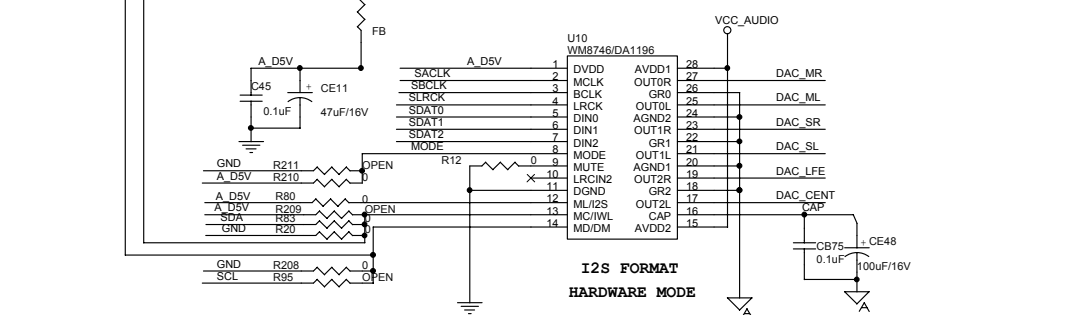
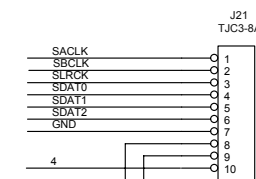

CIRCUIT DIAGRAM - DVD MPEG BOARD

MPEG board is not repaired, program for reference only.

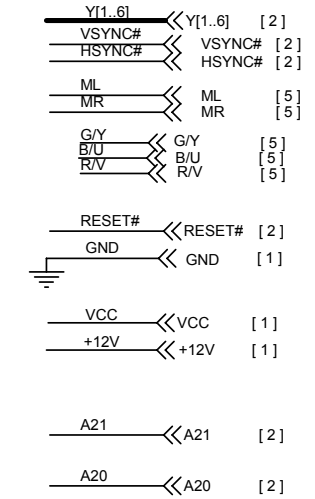
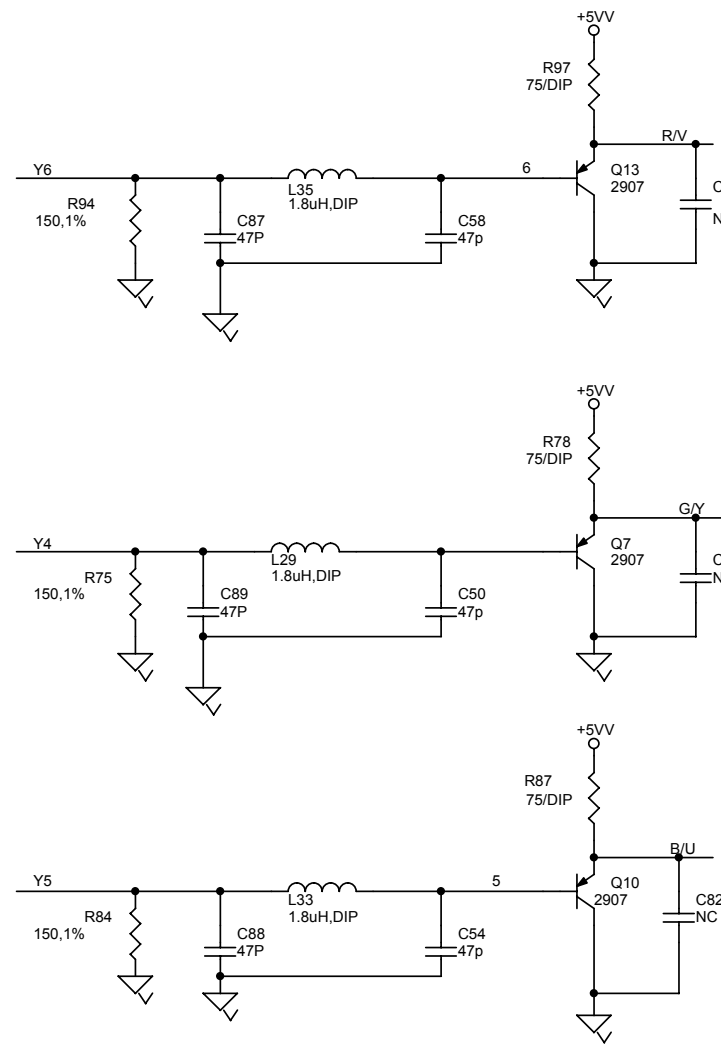
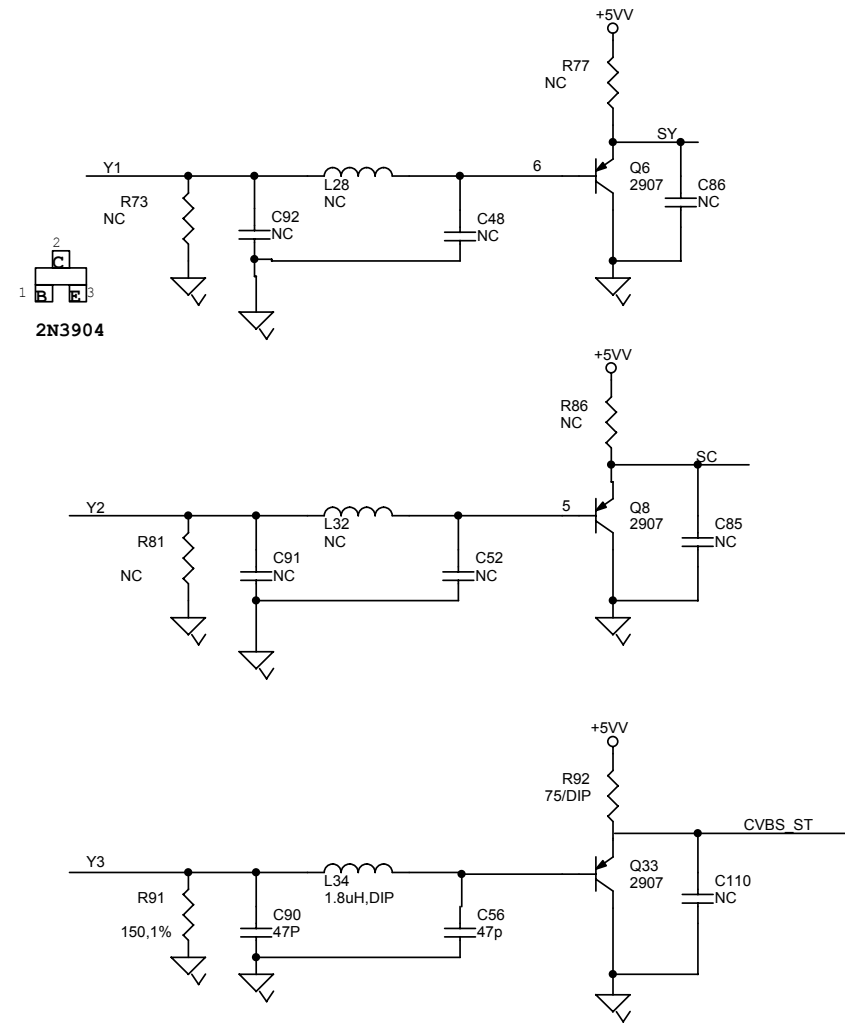

SCART CONNECTOR

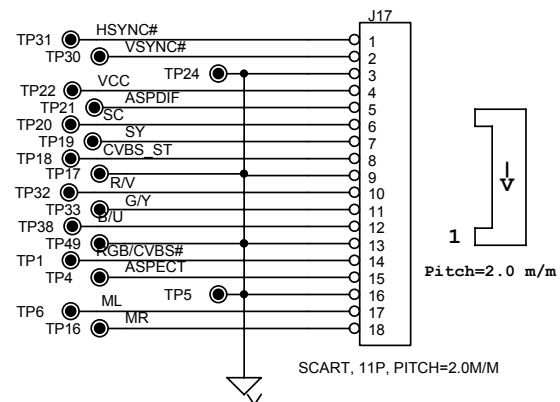

SCART CONTROL

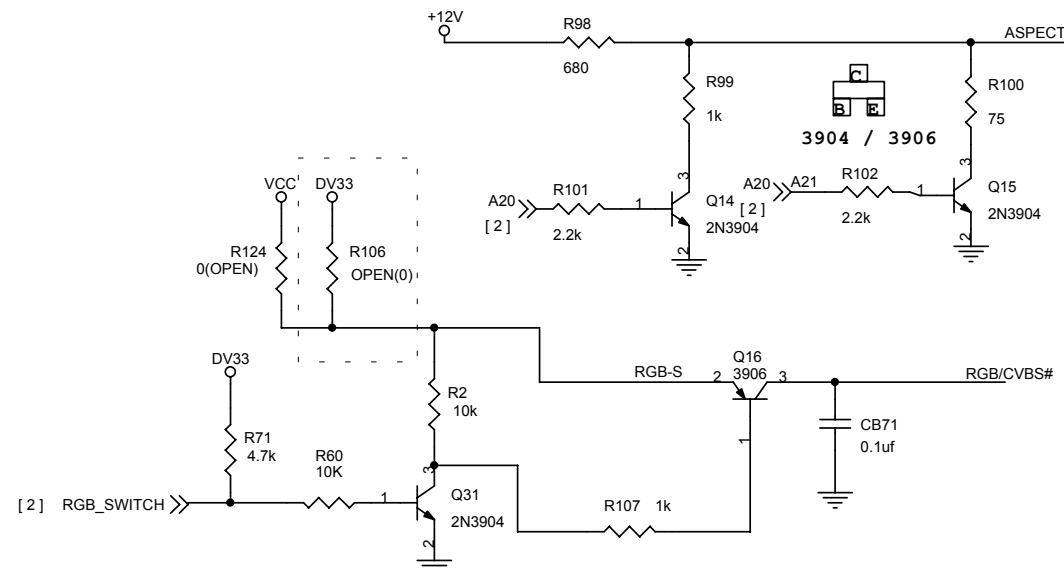

CIRCUIT DIAGRAM - DVD MPEG BOARD

MPEG board is not repaired, program for reference only.

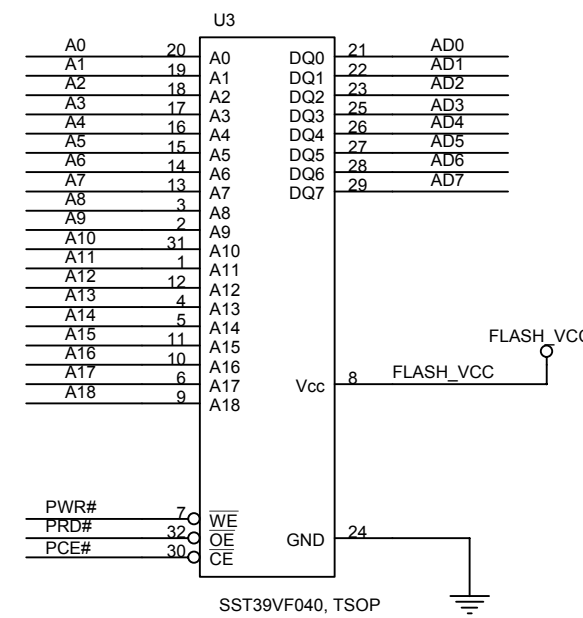
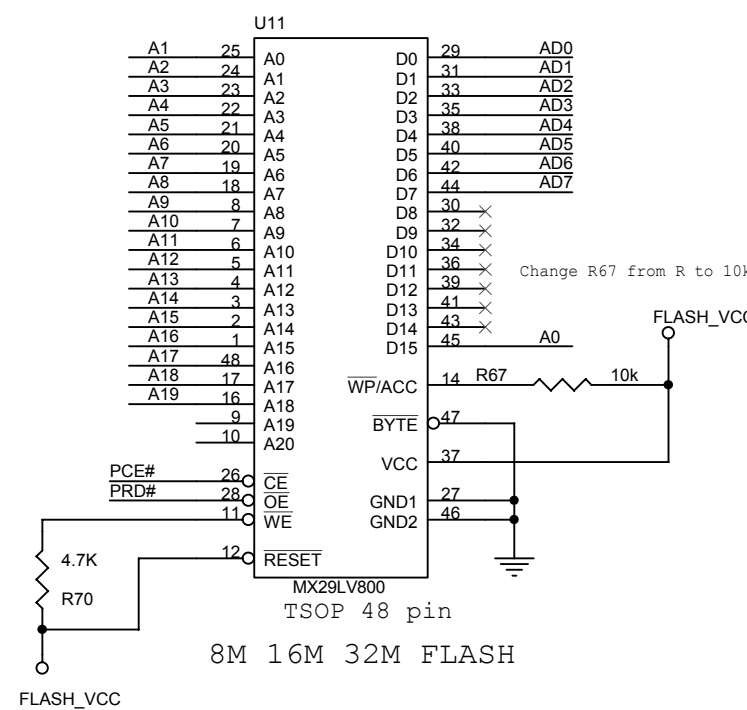
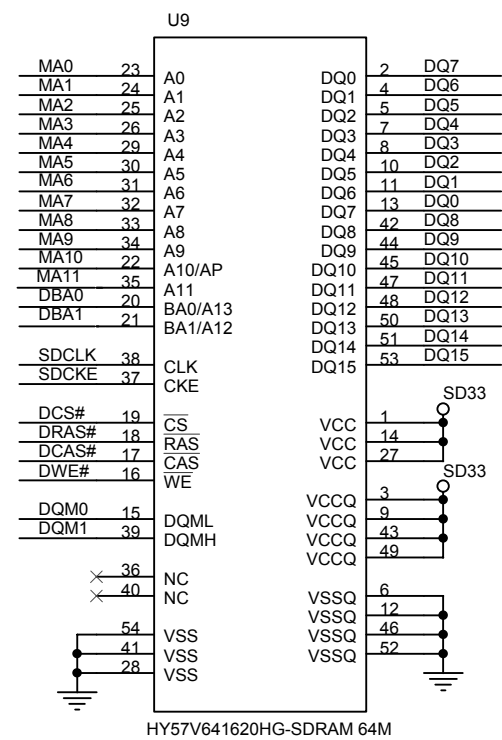
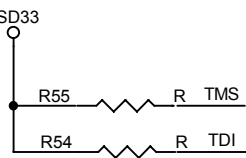
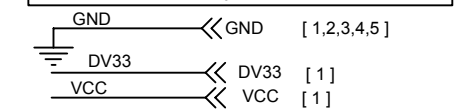
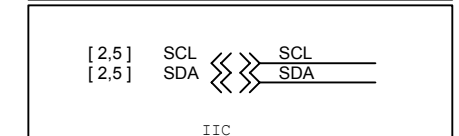
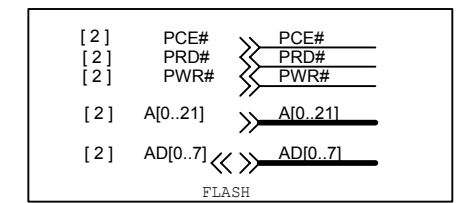
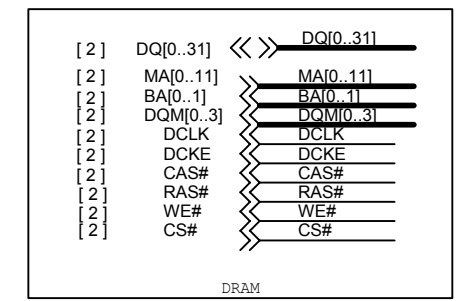
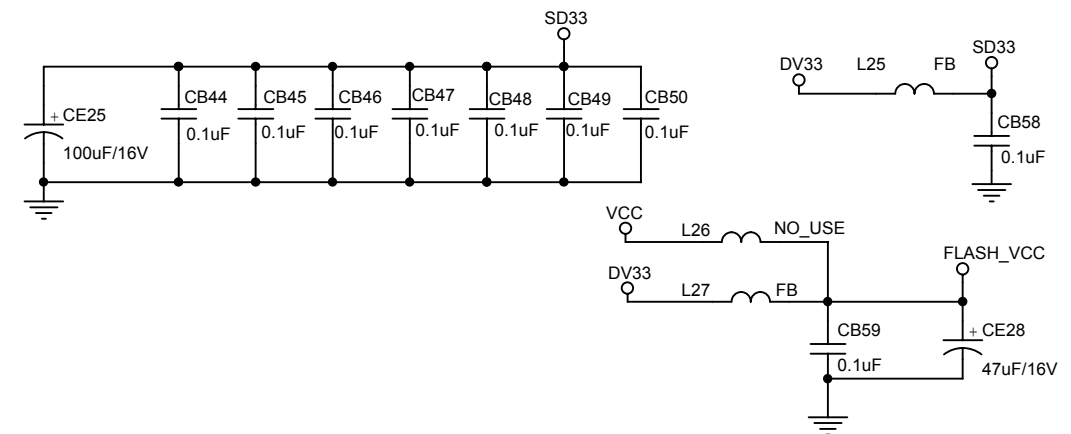
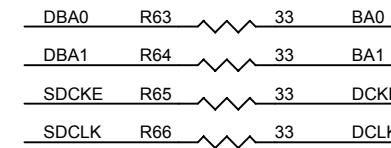
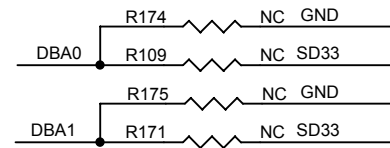
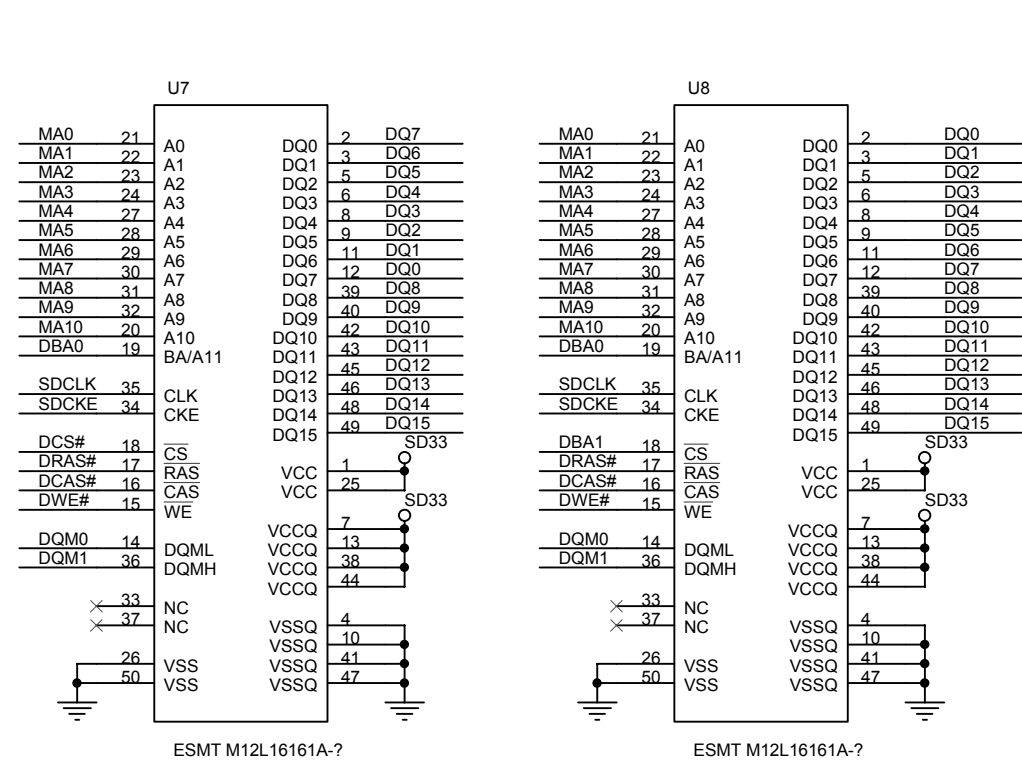

CIRCUIT DIAGRAM - DVD MPEG BOARD

MPEG board is not repaired, program for reference only.

- | | |
|---|---|
| 1 | INDEX & POWER, RESET |
| 2 | RF, SERVO & MPEG - MT1389E |
| 3 | MEMORY - SDRAM, FLASH/EEPROM |
| 4 | VIDEO OUT |
| 5 | AUDIO DAC WMA8746&WMA8720 AND AUDIO OUT |

NAME	TYPE	DEVICE
VCC	Digital 5V	SUPPLY
DV33	Digital 3.3V	MT1389E
RFV33	Servo 3.3V	MT1389E
LDO_AV33	Laser Diode 3.3V	
AVCC	RF 5V	PICKUP HEADER
V18	Digital 1.8V	MT1389E
SD33	Digital 3.3V	SDRAM
+12V	Audio +12V	OP AMP.
-12V	Audio -12V	OP AMP.
AVDD	Audio 5V	Audio DAC
DVDD	Audio 5V	Audio DAC

Rev	History	P#	Date
V1	The original released.		2003.6.15
V2	Change CE11 from 10uF to 100uF Change C3 from C to 2200pF Change C2 from 0.1uF to C Change R10, R15 from 750k to 680k Change R17, R19 from 390k to 150k Add C74 2200pF Change R37 from 0 to R Change R38 from 0 to R Change C32 from 15nF to C Change PIN 47 from LIMIT to ADIN Add CE1 10uF Change R15 from 1.5k to 1.8k Remove 74H04 Change the LIMIT signal from PIN 46 to PIN136 Change R4, R5, R6, R8, R12 from 1k to R Change the TRIN4TROUT pullhigh power from 5V to 3V3 Add LC circuit Change R67 from R to 0k Add the low resistance output circuit Change spdif output port Add the Audio DAC power to reference filtering	1	2003.7.17

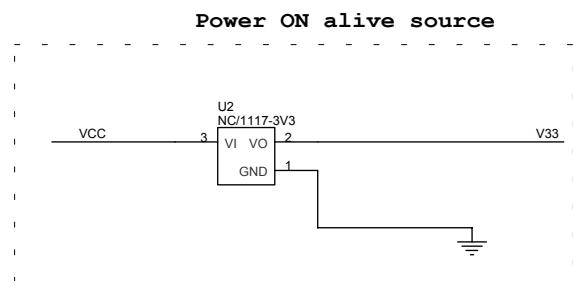
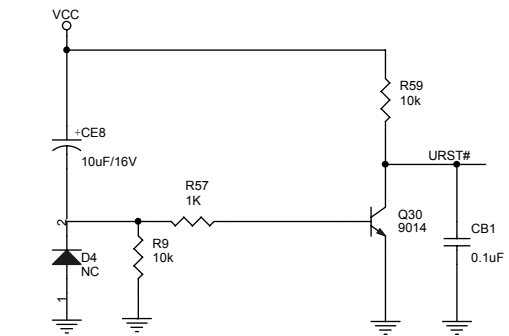
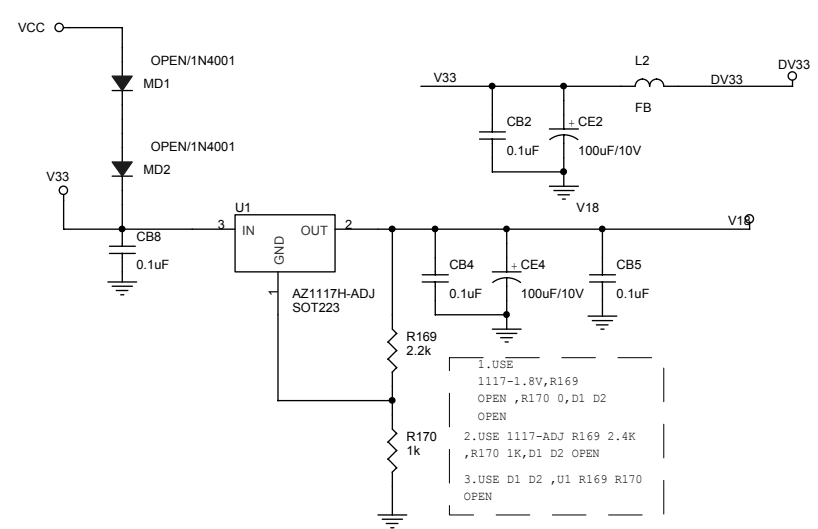
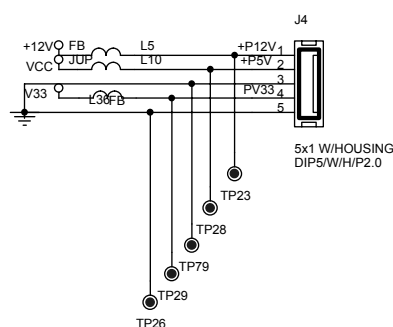

- URST# >>> URST# [2]
- V18 >>> V18 [2]
- RFVCC >>> RFVCC [2]
- LDO_AV33 >>> LDO_AV33 [2]
- DV33 >>> DV33 [2,3,4,5]
- VCC >>> VCC [2,3,4,5]
- AVCC >>> AVCC [2]
- VCC_AUDIO >>> VCC_AUDIO [5]
- +12V >>> +12V [4,5]
- 12V >>> -12V [4,5]
- +12V1 >>> +12V1 [5]
- GND >>> GND [2,3,4,5]
- POWER_STB >>> POWER_STB [2]
- MIC2 >>> MIC2 [5]
- MIC_EN >>> MIC_EN [2,5]

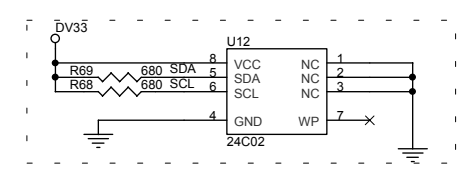
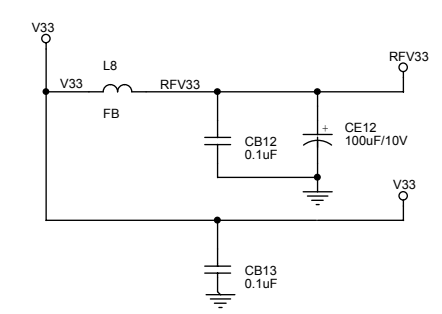
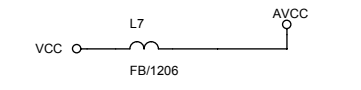
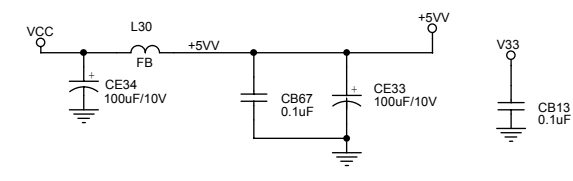
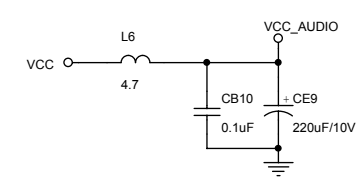

CIRCUIT DIAGRAM - DVD MPEG BOARD

MPEG board is not repaired, program for reference only.

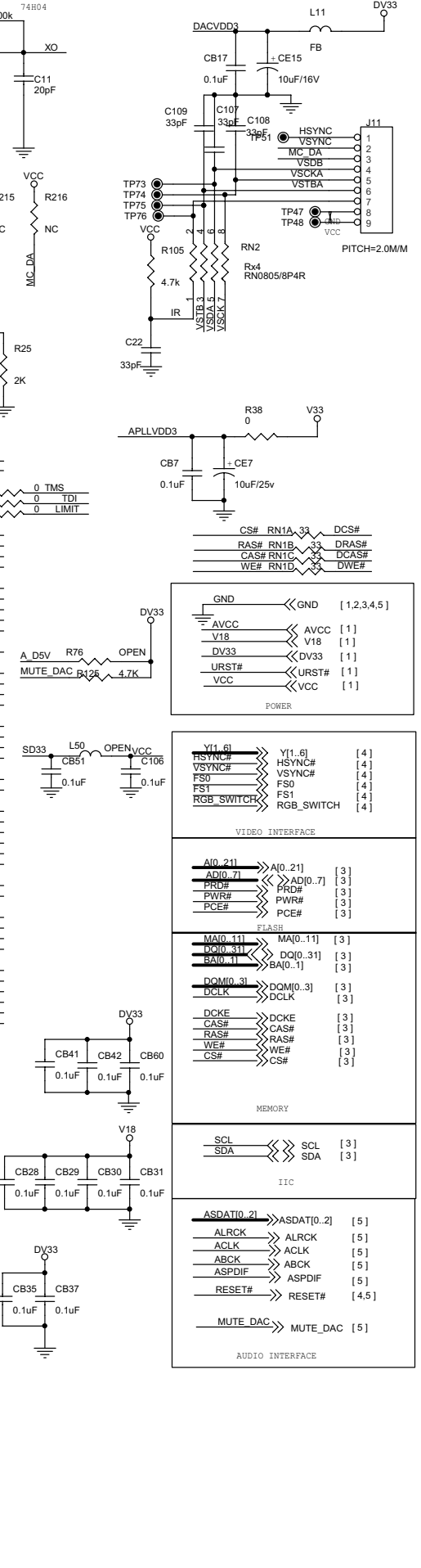
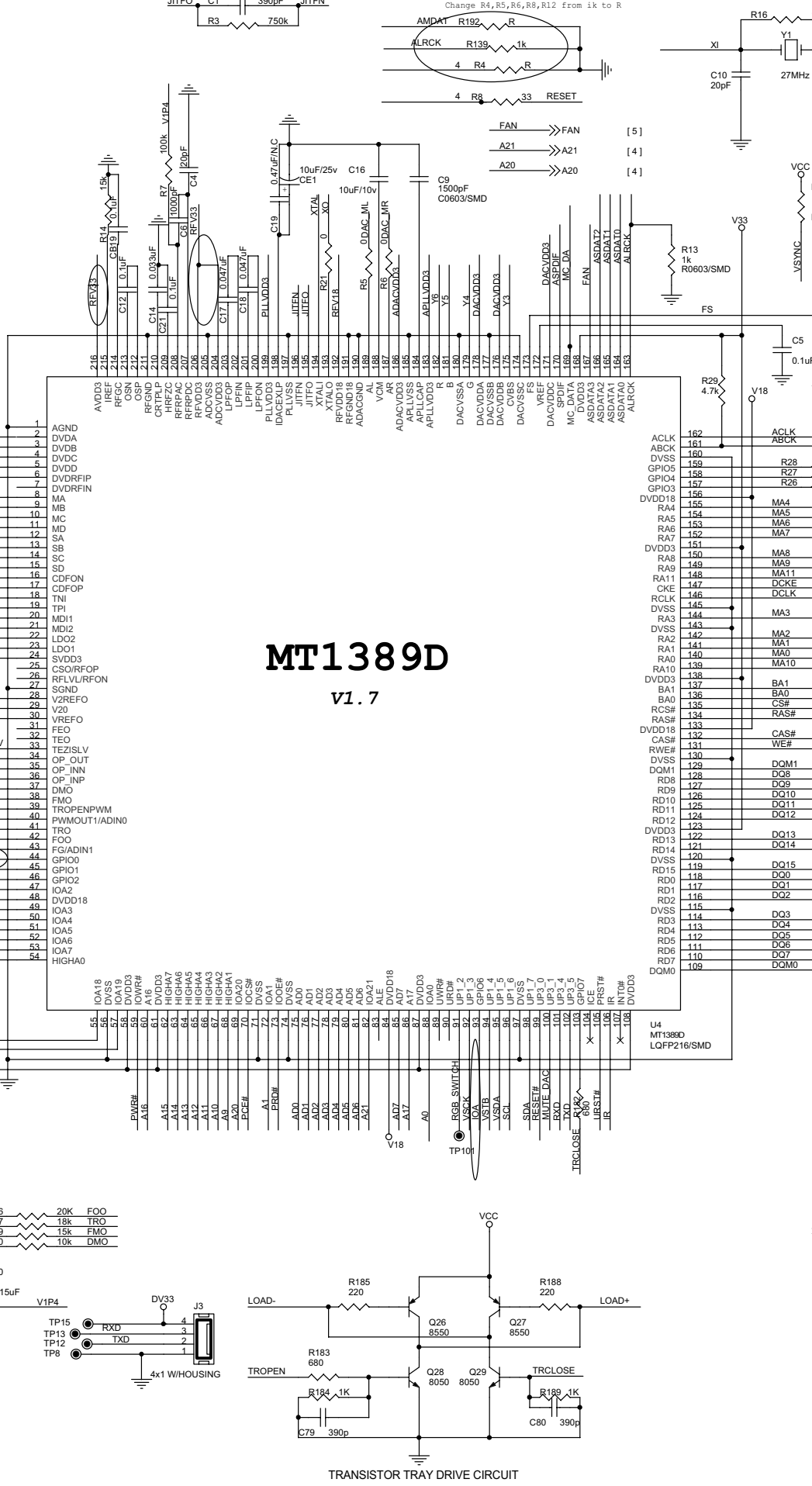
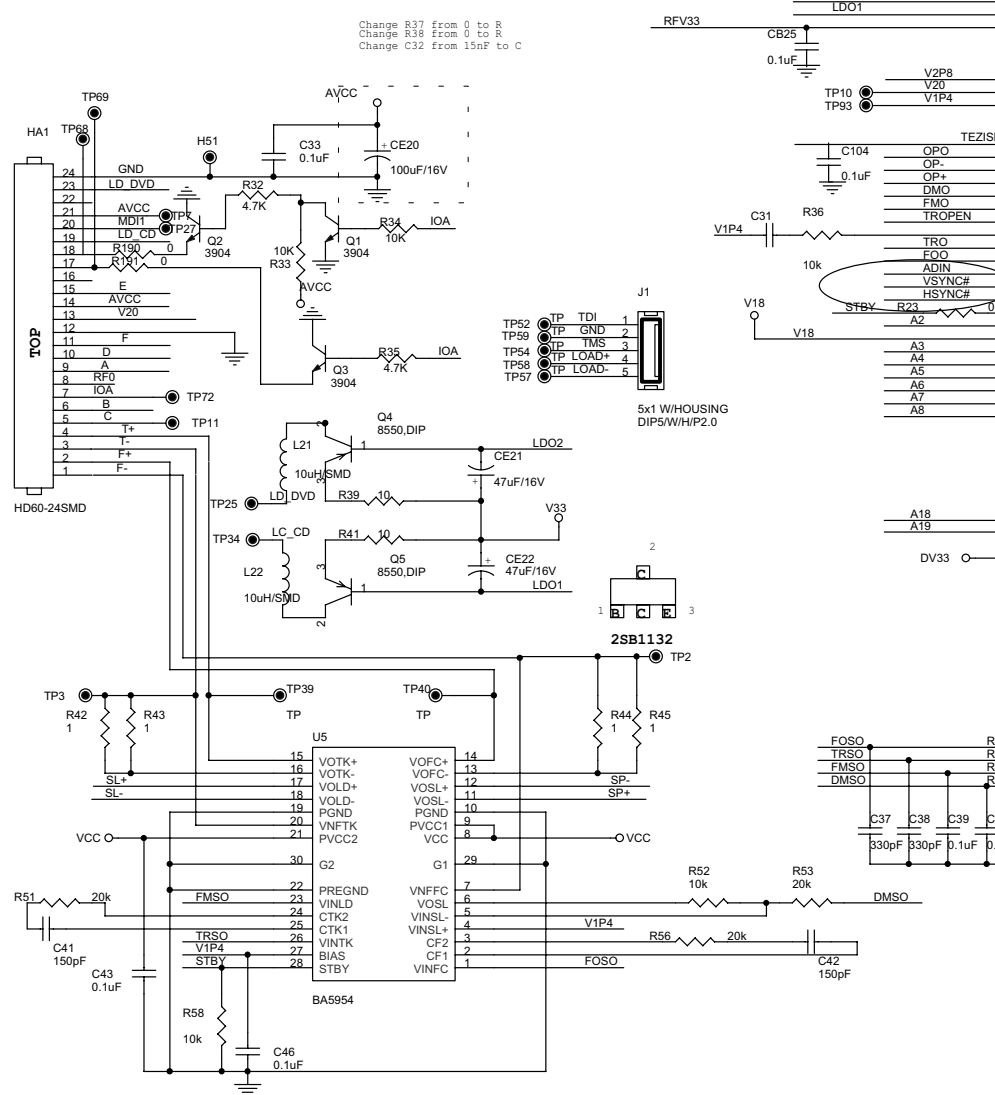
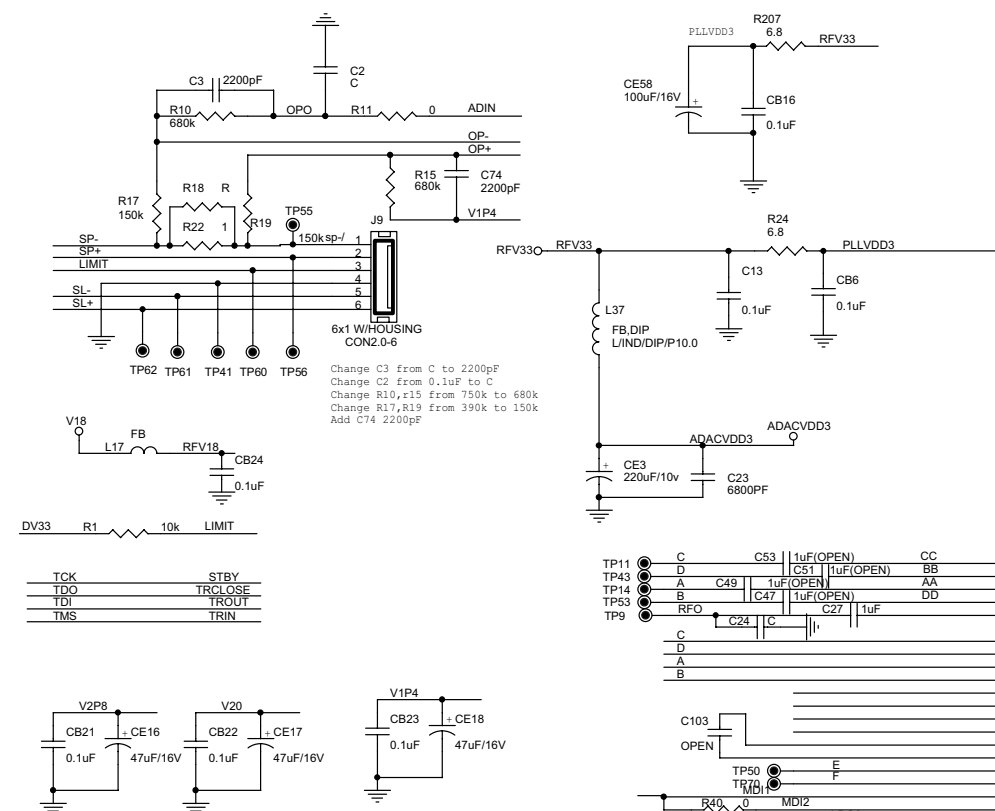

MT1389D V1.7

TRANSISTOR TRAY DRIVE CIRCUIT

LAYOUT DIAGRAM - DVD MPEG BOARD

MPEG board is not repaired, program for reference only.

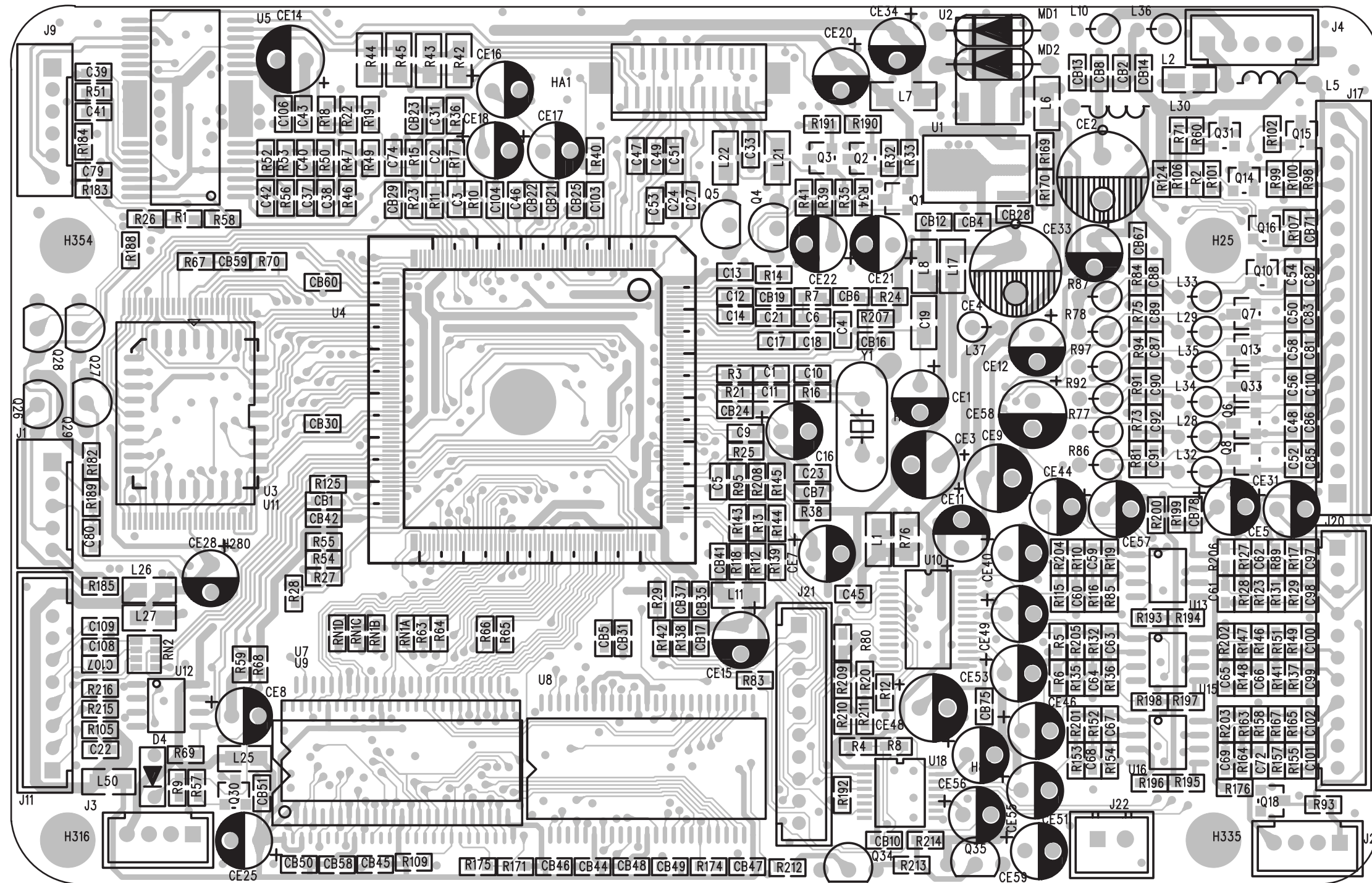

EXPLODED VIEW DIAGRAM

SCREW LIST

①	M2.5x5
②	M2.5x8
③	M2.5x10
④	M3x8
⑤	M3x10
⑥	TP2.5x4
⑦	TP2.5x10
⑧	T3 x4
⑨	T3 x8
⑩	T3 x10

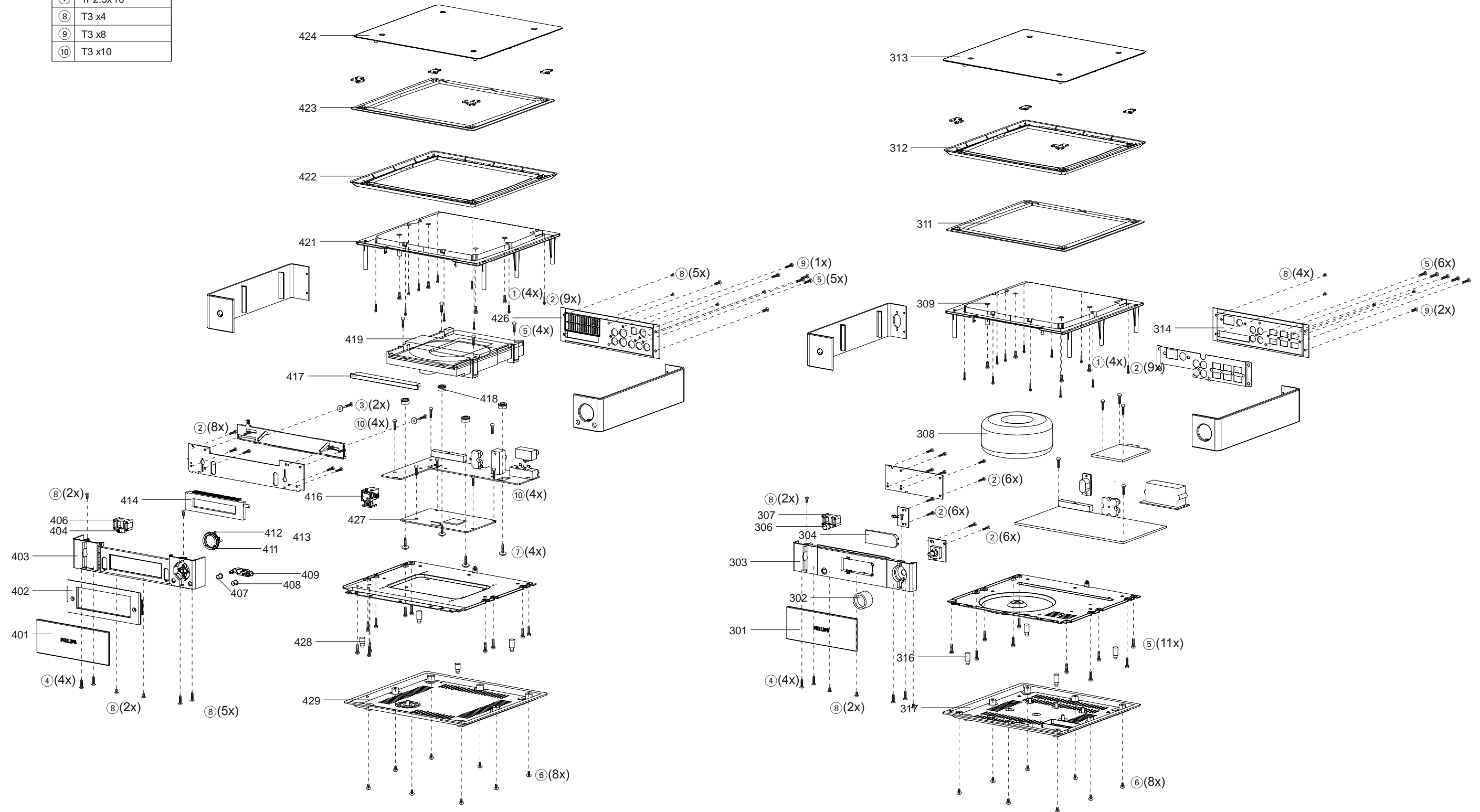

MECHANICAL PARTSLIST - AMP PART**ACCESSORIES**

9940 000 03504	SPEAKER BOX ASS'Y
9940 000 03497	REMOTE HANDSET
9940 000 03506	SPEAKER CONNECTION WIRE (not for-/79)
9940 000 03584	SPEAKER CONNECTION WIRE (only for-/79)
9940 000 03507	AV CABLE (not for -/79)
9940 000 03585	AV CABLE (only for -/79)
9940 000 03508	AC LINE CORD (-/98)
9940 000 03514	AC LINE CORD (-/12)
9940 000 03456	AC LINE CORD (-/93/79)
9940 000 02562	AM ANTENNA HOLDER
9940 000 03516	1P WIRE 26# 1.5M
9940 000 03517	SINGLE JUMPER WIRE 26#
9940 000 03409	PHILIPS BRACKET ASS'Y

MECHANICAL PARTSLIST

301	9940 000 03478	AMP LENS
302	9940 000 03487	AMP VOLUME KNOB
303	9940 000 03465	AMP FRONT CABINET
304	9940 000 03481	LOGO LIGHT GUIDE
306	9940 000 03482	AMP SOURCE BUTTON
307	9940 000 03492	AMP SOURCE BUTTON-BRACKET
308	9940 000 03583	POWER TRANSFORMER 240V/50Hz (-/79)
308	9940 000 03503	POWER TRANSFORMER 230V/50HZ (-/93)
308	9940 000 03513	POWER TRANSFORMER 230V/50HZ (-/12)
308	9940 000 03515	POWER TRANSFORMER 120/230V (-/98)
309	9940 000 03467	TOP COVER1
312	9940 000 03468	TOP COVER2
313	9940 000 03469	AMP TOP COVER
314	9940 000 03472	AMP BEAR CABINET
316	9940 000 03491	RUBBER FOOT(B)
317	9940 000 03474	AMP BOTTOM

Note: Only these parts mentioned in the list are normal service parts.

MECHANICAL PARTSLIST - DVD PART

401	9940 000 03479	DVD LENS
402	9940 000 03495	DVD DOOR BRACKET
403	9940 000 03466	DVD FRONT CABINET
404	9940 000 03488	DVD STANDBY BUTTON
406	9940 000 03496	DVD STANDBY BUTTON-BRACKET
407	9940 000 03484	DVD CONTROL BUTTON-1
408	9940 000 03485	DVD CONTROL BUTTON-2
409	9940 000 03493	DVD CONTROL BUTTON BRACKET
411	9940 000 03483	DVD SKIP BUTTON
412	9940 000 03494	DVD SKIP BUTTON BRACKET
413	9940 000 03486	DVD CONTROL BUTTON CENTRE
414	9940 000 03413	VFD DISPLAY
416	9940 000 03459	MOTOR RF-360C-13450
417	9940 000 03476	DVD DOOR
418	9940 000 03455	DVD MECHANISM RUBBER CUSHION(not for -/12)
418	9940 000 03185	DVD MECH. RUBBER CUSHION (-/12)
419	9940 000 03461	DVD MECHANIS MKENWOOD 510
421	9940 000 03467	TOP COVER1
422	9940 000 03477	TOP LIGHT LENS
423	9940 000 03468	TOP COVER2
424	9940 000 03471	DVD TOP COVER
426	9940 000 03473	DVD BERA CABINET
427	9940 000 03505	DVD MPEG DECODER CARD ASS'Y
428	9940 000 03489	RUBBER FOOT(A)
429	9940 000 03475	DVD BOTTOM
	9940 000 03457	AC SOCKET 1A/250V
	9940 000 03499	FLAT FLEX CABLE 24P

Note: Only these parts mentioned in the list are normal service parts.

ELETRICAL PARTSLIST - AMP PART**- DIODES -**

DZ901	9940 000 02516	ZENER DIODE 5V1
ZD304	9940 000 03417	ZENER DIODE 5.6V
ZD301	9940 000 03417	ZENER DIODE 5.6V
DB1	9940 000 03418	THYRISTOR RS1010G(10A)
DZ303	9940 000 03419	ZENER DIODE BZX-79-B22V
DZ302	9940 000 03419	ZENER DIODE BZX-79-B22V
DZ302	9940 000 03501	ZENER DIODE BZX-79-B24V
DZ303	9940 000 03501	ZENER DIODE BZX-79-B24V
DB1	9940 000 03502	THYRISTOR RS808
LED1001	9940 000 03436	WHITE LED DIODE
LED1100	9940 000 03437	LED 3B4SCB01
LED1101	9940 000 03437	LED 3B4SCB01
LED1103	9940 000 03437	LED 3B4SCB01
LED1104	9940 000 03437	LED 3B4SCB01
LED1200	9940 000 03437	LED 3B4SCB01
LED1201	9940 000 03437	LED 3B4SCB01

- TRANSISTORS -

Q302	9940 000 02517	TRANSISTOR 2SB772
Q1	9940 000 03156	CHIP TRANSISTOR 9014
Q2	9940 000 03156	CHIP TRANSISTOR 9014
Q2	9940 000 02545	TRRANSISTOR 9014C
Q3	9940 000 02518	TRANSISTOR 8050C
Q3	9940 000 03438	TRANSISTOR BC547B
Q301	9940 000 03439	CHIP RESISTOR BC817-25
Q304	9940 000 03439	CHIP RESISTOR BC817-25
Q308	9940 000 03439	CHIP RESISTOR BC817-25
Q309	9940 000 03439	CHIP RESISTOR BC817-25
Q1	9940 000 03441	TRRANSISTOR 9015C
Q303	9940 000 03442	CHIP TRANSISTOR BC857C
Q305	9940 000 03442	CHIP TRANSISTOR BC857C
Q311	9940 000 03442	CHIP TRANSISTOR BC857C
Q306	9940 000 03443	MOSFET BUK7535-55A
Q307	9940 000 03443	MOSFET BUK7535-55A
Q310	9940 000 03444	CHIP TRANSISTOR BC847C
Q312	9940 000 03444	CHIP TRANSISTOR BC847C
Q4	9940 000 03445	CHIP TRANSISTOR BC857C

- IC -

IC302	9940 000 02526	IC 7812
IC1	9940 000 03421	IC TEA5757H
IC301	9940 000 03422	IC TDA8920BTH
IC303	9940 000 03423	IC TDA8922BTH
IC304	9940 000 03423	IC TDA8922BTH
IC305	9940 000 03424	IC 74HCU04D



ELETRICAL PARTSLIST - AMP PART

IC306	9940 000 03425	IC HEF4013T
IC4	9940 000 03426	IC PT2323
IC5	9940 000 03427	IC NE008
IC6	9940 000 03427	IC NE008
IC11	9940 000 03427	IC NE008
IC7	9940 000 03428	IC PT2322
IC8	9940 000 03429	IC 4558

- COILS & FILTERS -

XT301	9940 000 03453	CERAMIC FILTER CRB 700KHz
XT302	9940 000 03454	CERMIC FILTER FREQUENCY 600KHz
CF2	9940 000 03153	CERMIC FILTER FREQUENCY 10.7MHz
CF1	9940 000 03153	CERMIC FILTER FREQUENCY 10.7MHz
T1	9940 000 03446	I.F.T. COIL 44023
T2	9940 000 03447	I.F.T. COIL 20591
T3	9940 000 03447	I.F.T. COIL 20591
T4	9940 000 03448	I.F.T. COIL 20382
T5	9940 000 03449	I.F.T. COIL 44108
T7	9940 000 03451	I.F.T. COIL 43462

- MISCELLANEOUS -

X1	9940 000 03452	QUARTZ CRYSTAL 75KHz
JACK1	9940 000 02528	4PINS RCA SOCKET
ENCODER801	9940 000 02535	VOLUME CODER ED-1612-00-F15
S1	9940 000 02542	IR SENSOR
SPK1	9940 000 03431	5.1 SPEAKER JACK 6PZ-1
SW901	9940 000 03432	LIGHT TOUCH SWITCH
F301	 9940 000 03433	FUSE F6.3AL250V
F302	 9940 000 03433	FUSE F6.3AL250V
CN10	9940 000 03434	PIN CONNECTOR 40PINS
JACK1	9940 000 03435	ANT. LEADING-OUT JACK
	9940 000 05328	ECO6-02 TUNER BOARD ASSY (only for -/12)

Note: Only these parts mentioned in the list are normal service parts.

ELETRICAL PARTSLIST - DVD PART**- DIODES -**

BD201	9940 000 02521	THYRISTOR RS406
D210	9940 000 02544	RECTIFIER DIODE IN5822
DZ201	9940 000 03407	ZENER DIODE 3.3V
DZ202	9940 000 03408	ZENER DIODE 27V
LED601	9940 000 02537	LED LAMP 3R4CB71D-2B-208 -/12



- TRANSISTORS -

Q201	9940 000 02519	TRANSISTOR 8550C
Q202	9940 000 02519	TRANSISTOR 8550C
Q206	9940 000 02519	TRANSISTOR 8550C
Q208	9940 000 02519	TRANSISTOR 8550C
Q203	9940 000 02518	TRANSISTOR 8050C
Q204	9940 000 02518	TRANSISTOR 8050C
Q207	9940 000 02518	TRANSISTOR 8050C
Q209	9940 000 02518	TRANSISTOR 8050C
Q210	9940 000 02518	TRANSISTOR 8050C
Q205	9940 000 02545	TRRANSISTOR 9014C
Q2201	9940 000 02518	TRANSISTOR 8050C -/12

- IC -

IC202	9940 000 02547	IC AT24C02-PC27
IC203	9940 000 03162	CPU U252
IC205	9940 000 03411	IC D4558/RC4558
IC207	9940 000 02548	IC LM7805/LM340T5 7805
IC208	9940 000 02546	IC YD2576-ADJ
IC601	9940 000 02539	IC PT6311 / SC16311 / CD16311
IC201	9940 000 03512	CHIP IC AC6811-/12

- MISCELLANEOUS -

X201	9940 000 03152	CERMIC FILTER FREQUENCY 4.19MHZ
X202	9940 000 02551	CRYSTAL OSC FREQ.32.768 KHz
F201	 9940 000 02529	FUSE F2AL250V
F209	 9940 000 03412	FUSE F1.5A/125V
VFD701	9940 000 03413	VFD DISPLAY
RCA204	9940 000 03414	RCA SOCKET
SW601	9940 000 02543	LIGHT TOUCH SWITCH
SW602	9940 000 02543	LIGHT TOUCH SWITCH
SW603	9940 000 02543	LIGHT TOUCH SWITCH
SW604	9940 000 02543	LIGHT TOUCH SWITCH
SW605	9940 000 02543	LIGHT TOUCH SWITCH
SW606	9940 000 02543	LIGHT TOUCH SWITCH
SW607	9940 000 02543	LIGHT TOUCH SWITCH
SW608	9940 000 02543	LIGHT TOUCH SWITCH
JACK1301	9940 000 02556	OPTICAL & COAXIAL TERMINAL SOCKET

ELETRICAL PARTSLIST - DVD PART

JACK202	9940 000 02553	3PINS RCA SOCKET(R/B/G)
CN210	9940 000 03415	PIN CONNOCOTR 34PINS
JACK4	9940 000 03416	RCA SOCKET+SVIDEO
J1201	9940 000 02558	SINGLE RCA SOCKET
J104	9940 000 02527	4PINS SPEAKER SOCKET
	9940 000 02566	110/220V AC CHANGE SWITCH -/98
REL1201	9940 000 03509	RELAY 10A 240VAC/30VDC -/12
J1501	9940 000 03511	SCART 21P SOCKET -/12
	9940 000 04649	ECO POWER TRANSFORMER (-/12)

Note: Only these parts mentioned in the list are normal service parts.

REVISION LIST

Version 1.0 (3141 785 30730)

* Initial Release MCD708/93/12/98/79

Version 1.1 (3141 785 30731)

* Page 13-4 : Electrical partslist - Update
- Add ECO Power Transformer (only for -/12)

Version 1.2 (3141 785 30732)

* Page 9-1 : Circuit diagram - CPU Board - Update
* Page 13-2 : Electrical partslist - Update
- Add ECO6-02 Tuner Board Assy (only for -/12)