

Service Manual

**74 CD72/21B/22B/25B/52B/55B
/21G/22G
Compact disc player**



**COMPACT
disc
DIGITAL AUDIO**

CONTENTS

SECTION	PAGE
1. TECHNICAL SPECIFICATIONS	1
2. LASER RADIATION SAFETY	2
3. MEASUREMENTS AND ADJUSTMENTS	3
4. SERVICE HINTS	6
5. EXPLODED VIEW AND MECHANICAL PARTS LIST	8
6. BLOCK DIAGRAM	11
7. SCHEMATIC DIAGRAM AND PARTS LOCATIONS (PATTERN SIDE)	13
8. ELECTRICAL PARTS LIST	31

**CLASS 1
LASER PRODUCT**

3122 110 03420

marantz®

model CD-72MKII/CD-72MKIISE

First issue: 1993

4822 725 51032

PCS 70 945

MARANTZ DESIGN AND SERVICE

Using superior design and selected high grade components, MARANTZ company has created the ultimate in stereo sound. Only **original MARANTZ parts** can insure that your MARANTZ product will continue to perform to the specifications for which it is famous.

Parts for your MARANTZ equipment are generally available at our National Marantz Subsidiary or Agent.

MARANTZ EUROPE B.V.
P.O. Box 80002
Building SFF 2
5600 JB Eindhoven
The Netherlands
Phone : +31-40-732241
Fax : +31-40-735578

ORDERING PARTS

Parts can be ordered either by mail or by telex. In both cases, the correct part number has to be specified. The following information must be supplied to eliminate delays in processing your order:

1. Complete address
2. Complete part numbers and quantities required
3. Description of parts
4. Model number for which the part is required
5. Way of shipment
6. Signature: any order form or telex must be signed, otherwise such part order will be considered as null and void.

ADDRESSES

AUSTRALIA
MARANTZ AUSTRALIA
Figtree Drive
Australia Centre
Homebush, NSW 2140
AUSTRALIA

FINLAND
MARANTZ
Kuortanegatan 1
00520
Helsingfors 52
Finland

ITALY
MARANTZ ITALIANA SPA
Piazza IV Novembre 3
20124 Milano
Italy

NORWAY
MARANTZ
Postboks 7034
Assiden
3007 Drammen
Norway

SPAIN
MARANTZ SPAIN
Martinez Villergas 2
Apartado 2065
Madrid 28027
Spain

AUSTRIA
MARANTZ
Hietzinger Kai 137a
1130 Wien
Austria

FRANCE
MARANTZ FRANCE
4 Rue Bernard Palissy
92600 Asnières
France

JAPAN
MARANTZ JAPAN INC.
35-1, 7-chome, Sagamiono
Sagamihara-shi, Kanagawa
Japan

PORTUGAL
COREL
Av. da Liberdade
211-2 Esq.
1200 Lisboa
Portugal

SWEDEN
MARANTZ
Box 1324
17125 Solna
Sweden

BELGIUM
MARANTZ EUROPE B.V.
Div. Benelux
P.O.Box 80002
Building SFF 2
5600 JB Eindhoven
The Netherlands

GERMANY
MARANTZ GERMANY GmbH
Kleine Heide 12
Postfach 4802
Halle-Westfalen
Germany

KUWAIT
AL ALAMIAH ELECTRONICS
P.O.Box 8196
Salmiah
22052 Kuwait

SAUDI ARABIA
AL ALAMIAH ELECTRONICS
P.O.Box 5954
University Street
Riyadh 11432
Saudi Arabia

SWITZERLAND
MARANTZ SWITZERLAND
Postfach
8010 Zürich-Müllingen
Switzerland

CHILE
MARANTZ DIVISION OF
PHILIPS S.A.
Av.Santa Maria 0760
Casilla 2687
Santiago
Chile

GREAT BRITAIN
MARANTZ HiFi UK Ltd.
Kingsbridge House
Padbury Oaks
575-583 Bath Road
Longford Middlesex UB7 OEH,
U.K.

NETHERLANDS
MARANTZ EUROPE B.V.
Div. Benelux
P.O.Box 80002
Building SFF 2
5600 JB Eindhoven
The Netherlands

SOUTH AFRICA
MARANTZ S.A.
10 Bond Street
Randburg 2194
P.O. Box 7703
Johannesburg 2000
South Africa

TRADING
MARANTZ TRADING
P.O.Box 20008
Building SFF 2
5600 JB Eindhoven
The Netherlands

DENMARK
MARANTZ
Horsvinget 5
2630 Tastrup
Denmark

GREECE
ADAMCO ELECTR. SA
P.O.Box 21025
Hippocrates Str. 188
Athens 11471
Greece

All of the above locations are fully equipped to take care of your total service needs or can advise you. Because various countries have differing configuration requirements, it is necessary that you contact the service facility in your particular country. In the event that there is no service location listed for your country, please contact the nearest facility for the necessary assistance.

In case of difficulties, do not hesitate to contact the Technical Department at above mentioned address.

LASER RADIATION SAFETY

Protection of eyes from laser beam during servicing.
This set employs a laser. Therefore, be sure to carefully follow the instructions below when servicing.

1. Laser Diode Properties

- Material: Al Ga As
- Wave Length: 0.78 μ m
- Emission Duration: Continuous
- Laser Output: Max. 0.11 mW

This output is the value measures at the objective lens surface on the light pen assembly.

2. During service, do not take the subchassis block apart and do not adjust the H F amp circuit. If there is a breakdown in the H F circuit (including laser diode), replace the entire subchassis block (including H F amp circuit board).

WARNING!!

When servicing, do not approach the laser exit with the eye too closely.

In case it is necessary to confirm laser beam emission, be sure to observe from a distance of more than 30 cm from the surface of the objective lens on the light pen assembly.

LASER WARNING LABELS

The labels shown below are affixed.

- 1) DHHS Protective housing label
"DANGER – INVISIBLE LASER RADIATION WHEN OPEN. AVOID DIRECT EXPOSURE TO BEAM."
- 2) DNHWS Protective housing label and laser radiation sign label
"CAUTION _ HAZARDOUS LASER RADIATION WHEN OPEN AND INTERLOCK DEFETED."
"ATTENTION _ RAYONNEMENT LASER DANGFEREUX SI OUVERT AVEC L'ENCLenchement DE SECURITE ANNULE."

TECHNICAL SPECIFICATIONS

Audio Characteristics

Channels	2 channels
D/A conversion	1-bit linear/channel

Frequency Characteristics

Line output jack (FIXED)	2 to 20,000 Hz, ± 0.2 dB
Line output jack (VARIABLE)	2 to 20,000 Hz, ± 0.2 dB
Dynamic range	98 dB
S/N ratio	100 dB
Channel separation	96 dB or more (1 kHz)
THD	0.003 % (1 kHz)
Wow & flutter	Precision of quartz
Analog output jacks	
Line output jacks (FIXED)	Output level 2 V RMS Output impedance 200 ohms
Matching load impedance	10 kohms or more
Line output jack (VARIABLE)	Output level 4 V RMS Output impedance 200 ohms
Matching load impedance	10 kohms or more
Digital output	Pin jack, 0.5 Vp-p/75 ohms (Rectangular optical connector) optical output -19 dBm

Optical Readout System

Laser	AlGAs semiconductor
Wavelength	780 nm

Signal System

Sampling frequency	44.1 kHz
Quantization	16 -bit linear/channel
Error correction	Cross-interleave reed solomon code (CIRC), Class A D/A conversion

Power Supply

/22/52 version	230 V AC 50/60 Hz
/25/55 version	240 V AC 50/60 Hz
/21 version	110–120/220–240 V AC 50/60 Hz
Power Consumption	12 W

Cabinet, etc.

Dimensions (Black)	
Width	420 mm
Height	119 mm
Depth	297 mm
Net weight	5 kg
Operating temperatures	+ 5 °C ~ + 35 °C
Operating humidity	5 % ~ 9 % (without Dew)

Accessories

Remote control unit (RC-72CD)	1
Dimensions (W x H x D)	60 x 15 x 175 mm
Weight (without batteries)	85 g
R03 Batteries	2
Stereo audio cable with RCA pins	1

MEASUREMENTS AND ADJUSTMENTS

TROUBLE SHOOTING (FAULT FINDING TREE)

Follow the path of the faultfinding tree beginning at the top left. Perform the actions you come across in the various blocks. Look at the various side branches to find out if the information you see there applies to your problem. If, for instance, you find the indication **display**, this means that no picture appears on the display.

If you establish this fault, follow the branch and perform the recommended actions. Check the signals mentioned. In a number of branches further reference is made to measurements you could carry out. These measurements are explained in several tables further on in this manual.

START-UP PROCEDURE

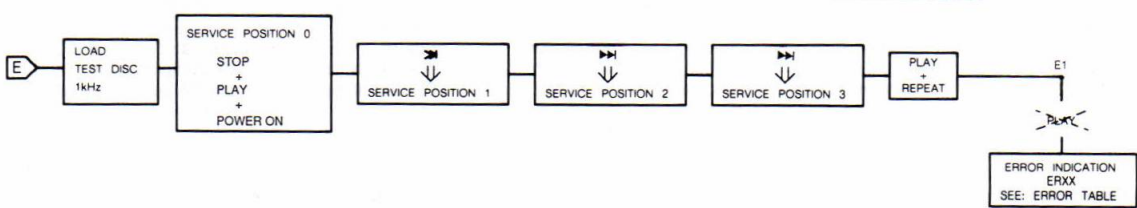
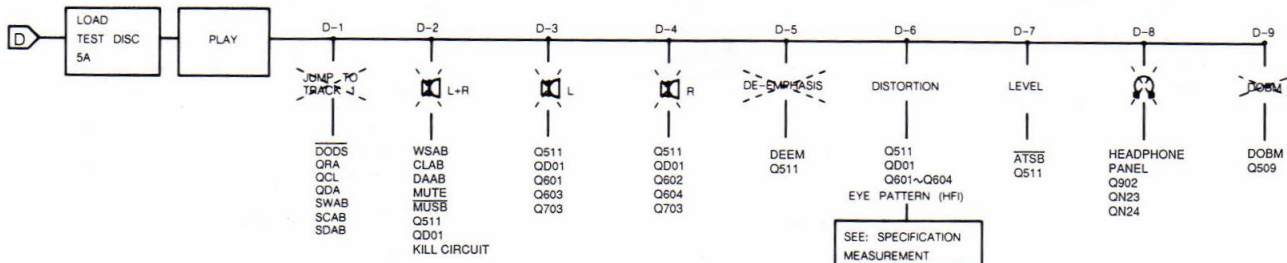
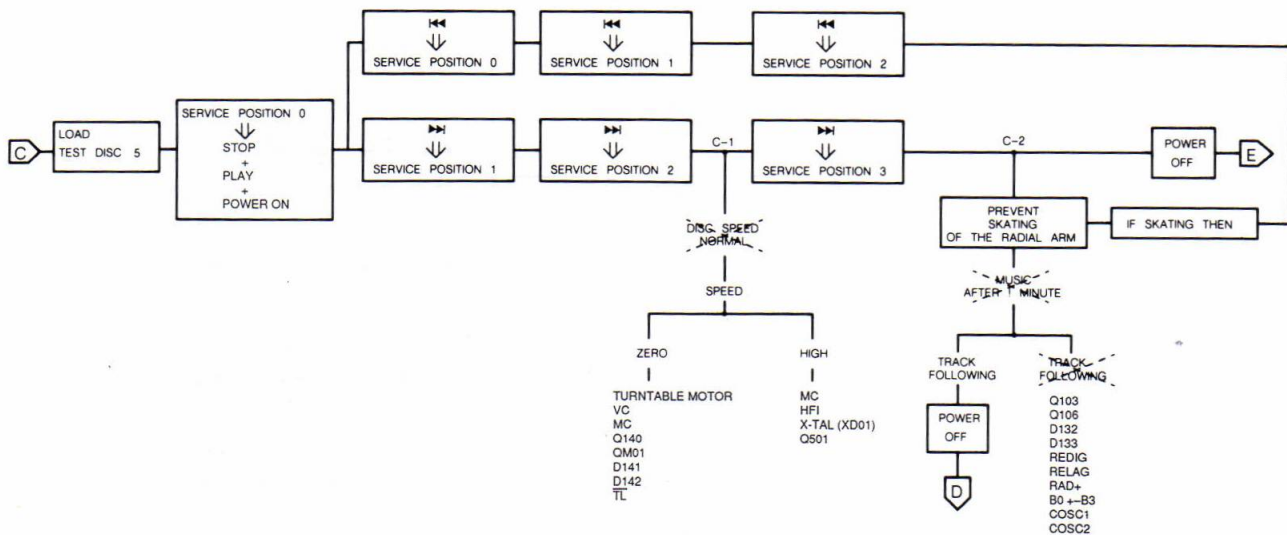
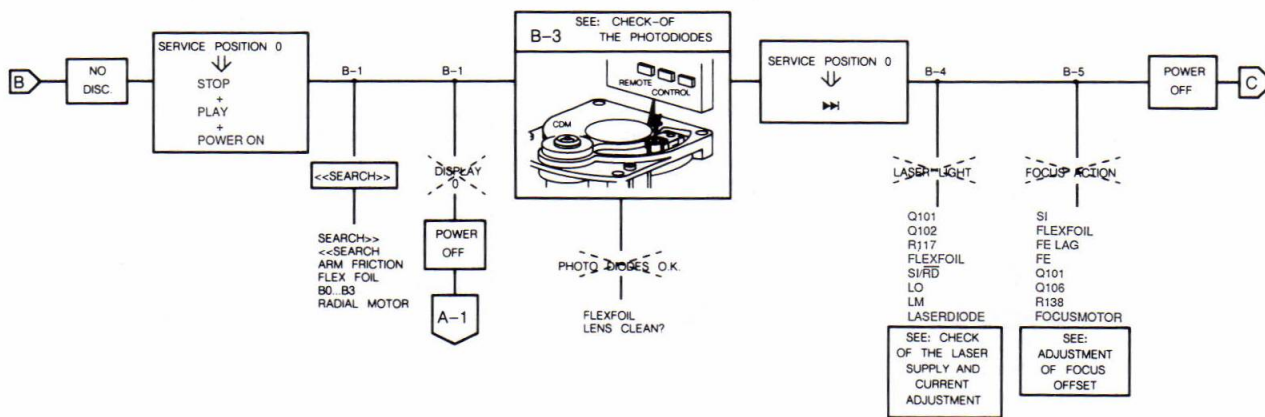
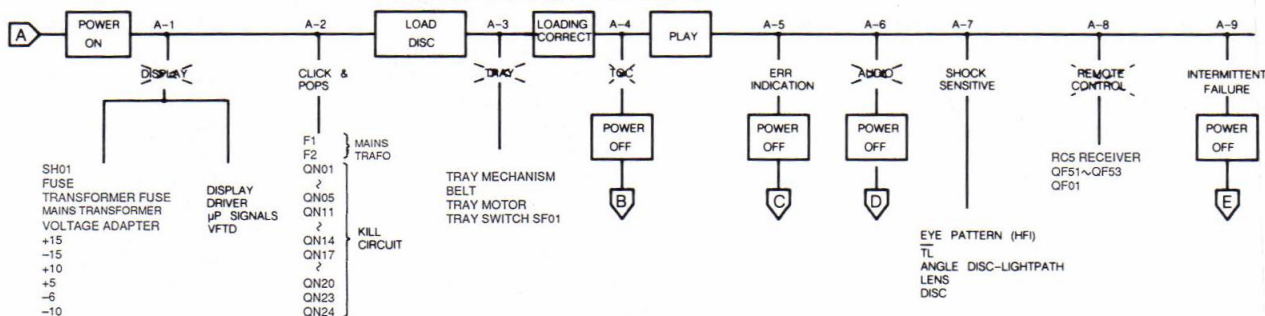

B-3 CHECK OF THE PHOTODIODES

Step	Signal	Mode					Remarks
1	D2 D1 D3 D4	power on	 	-	-	signal 4=6=7=8	Signal depends on Distance lens ↔ IR LED of remote control

T-22793A

B-4 CHECK OF LASER SUPPLY

The laser, the lasersupply plus the monitor diode form a feedback system.

A defect in the lasersupply may result in the destruction of the laser. If, in that case, the laser is replaced, (= complete C.D.M.-unit) the new laser will also become defective. However, it is impossible to check and repair a feedback system if a link is missing. For this reason the laser supply can be checked with the replacement circuit for laser assembly.

Step	Signal	Mode			Remarks
1	LO	serv. pos. 2 SK		1.8 < V < 2.3	
	LM			170 < mV < 220	
2	LO	serv. pos. 2 SK		1.8 < V < 2.3	
	LM			170 < mV < 220	
3	LO	Power on		0V ± 0.2V	No light

After opening SK the LED will emit a little more light for a short moment.

T-22793B

B-4 LASER CURRENT ADJUSTMENT

STEP	SIGNAL	MODE					REMARKS	
1	--	POWER OFF	--	--	--	--	CHECK IF FLEX-FOIL IS PROPERLY CONNECTED	
2	--	POWER OFF		R134	1kΩ +10% -0	--	PRE ADJUSTMENT OHMIC VALUE	
3	--	POWER OFF	--	R136	--	--	SET TO MID-POSITION	
4	LASER CURRENT VOLTAGE ACROSS R114	TEST DISC 5A PLAY			mV DC	--	IF < 15mV THEN GO TO STEP 3 AND SET R136 TO 1/4 OR 3/4. TRY AGAIN	
5	LASER CURRENT VOLTAGE ACROSS R114	TEST DISC 5A PLAY			mV DC	R134	50mV	--
6	FE-LAG	TEST DISC 5A TRACK 1 PLAY			mV DC	R136	400mV	--

MDA 02673
T28/020**B-5
ADJUSTMENT OF FOCUS-OFFSET**

Step	Signal	Mode					Remarks
1	-	Power on no disc	-	R136	-	-	adjust for optical mid-position of the focus motor
2	FE LAG	Play Test disc 5 Track 1	22	R136	400mV ± 40 mV DC	-	fine adjustment

DISASSEMBLY OF LOADING AND CAM

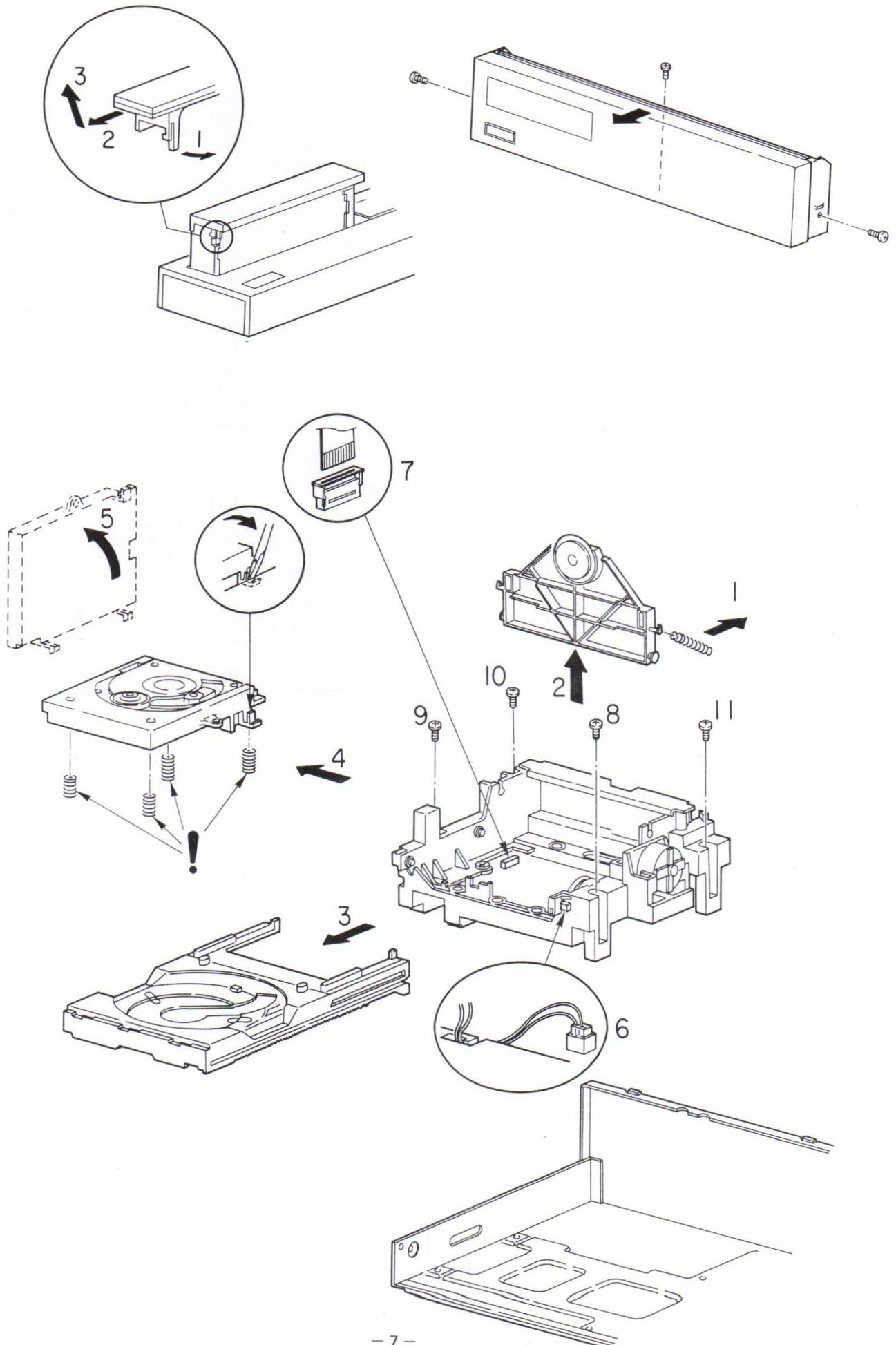

MECHANICAL PARTS LIST

(288K)

REF. DESIG.	PART NO.	DESCRIPTION
001B	4822 444 40482	FRONT PANEL ASSY (BLACK) [21B/22B/25B/52B/55B]
001B	4822 444 40681	FRONT PANEL ASSY (GOLD) [21G/22G]
003B	4822 410 61551	BUTTON,10 KEYS (BLACK) [21B/22B/25B/52B/55B]
003B	4822 410 61557	BUTTON,10 KEYS (GOLD) [21G/22G]
004B	4822 381 11285	LENS,LED PLAY/PAUSE
005B	4822 410 61552	BUTTON,PLAY/PAUSE (BLACK) [21B/22B/25B/52B/55B]
005B	4822 410 61558	BUTTON,PLAY/PAUSE (GOLD) [21G/22G]
006B	4822 444 40479	FRONT PANEL AL UPPER (BLACK) [21B/22B/25B/52B/55B]
006B	4822 444 40485	FRONT PANEL AL UPPER (GOLD) [21G/22G]
011B	4822 444 40481	FRONT PANEL AL LOWER (BLACK) [21B/22B/25B]
011B	4822 444 40486	FRONT PANEL AL LOWER (GOLD) [21G/22G]
011B	4822 444 40575	FRONT AL LOWER (BLACK) [52B/55B]
016B	4822 459 11096	BADGE,SPECIAL EDITION (GOLD) [52B/55B]
020B	4822 450 62099	WINDOW [21B/22B/25B/21G/22G]
020B	4822 450 62119	WINDOW [52B/55B]
021B	4822 459 10943	BADGE,MZ (GOLD/BLACK)
030B	4822 256 91819	HOLDER, F.L. TUBE
031B	4822 459 10942	STICKER ADHESIVE SHEET
041B	4822 502 13315	B.T.SCREW(W/TL)
043B	4822 410 60873	KNOB,HEAD PHONE VOLUME (BLACK) [21B/22B/25B/52B/55B]
043B	4822 413 41642	KNOB,HEAD PHONE VOLUME BROWN (GOLD) [21G/22G]
060B	4822 410 61556	BUTTON,POWER (BLACK) [21B/22B/25B/52B/55B]
060B	4822 410 60741	BUTTON,POWER (GOLD) [21G/22G]
071B	4822 444 40693	ESCUTCHEON,TRAY LID (BLACK) [21B/22B/25B/52B/55B]
071B	4822 444 40694	ESCUTCHEON,TRAY LID (GOLD) [21G/22G]
072B	4822 532 12112	RETAINER, TRAY LID
004D	4822 444 40499	SIDE PANEL (GOLD) [21G/22G]
007D	4822 501 11008	B.T.SCREW(W/W) (BLACK) [21B/22B/25B/52B/55B]
007D	4822 502 30732	SCREW, BIND B-TITE 4x13 (GOLD) [21G/22G]
009D	4822 444 60607	CAP (GOLD) [21G/22G]
004G	4822 462 41947	LEG,GOLD ALUMINUM CAP
030G	4822 402 61394	LINK,POWER SWITCH
911G	4822 325 50202	BUSHING, AC CORD [52B/55B]
SH02	4822 277 21561	SLIDE SWITCH, VOLTAGE SELECTOR (BLACK) [21B/21G]
W001	4822 321 11004	A.C. POWER CORD [21B/21G] 1A 250V
W001	4822 321 10249	A.C. POWER CORD [22B/22G] 2.5A
W001	4822 321 10629	A.C. POWER CORD [25B/55B]
W001	4822 321 10804	A.C. POWER CORD [52B]
001M	4822 464 50872	CHASSIS, LOADING FRAME
002M	4822 402 50276	LEVER, SWITCH BRACKET
003M	4822 492 52123	SPRING, COMPSRING
010M	4822 528 81447	PULLEY,MOTOR

REF. DESIG.	PART NO.	DESCRIPTION
015M	4822 358 10115	BELT,TRAY DRIVE
016M	4822 528 81455	PULLEY,DRIVE
020M	4822 402 61132	GUIDE,FRAME R
025M	4822 402 61252	GUIDE,FRAME L
026M	4822 492 52094	SPRING, COMPRESSION
029M	4822 532 11396	WASHER
030M	4822 492 51902	SPRING
031M	4822 466 61587	BUFFER, SUSPENS. GROMMET
035M	4822 691 30209	MECHANISM, CDM4 MINI
036M	4822 402 61196	CHASSIS, SUPPORT PIECE
040M	4822 466 92251	TRAY, LIFT PLATE ASSY
050M	4822 444 50603	TRAY ASSY
052M	4822 532 51756	BUFFER, DAMPING GROMMET
061M	4822 444 60568	LID,CLAMPER ARM
062M	4822 528 90639	ROLLER,CLAMPER
063M	4822 466 92257	RETAINER, PIVOT PLATE
064M	4822 402 61207	CENTRING RING
065M	4822 530 80503	CLAMPER, PRESSURE RING K
068M	4822 520 40177	SUSTAINER, BEARING BALL
073M	4822 462 42044	BUFFER,060M
075M	4822 492 32883	SPRING, TENSION
M001	4822 361 30368	D.C.MOTOR, TRAY DRIVE
001T	4822 736 21802	PACKING USER MANUAL CD-72MK2 [21B/22B/25B/21G/22G]
001T	4822 736 21827	USER MANUAL CD-72MK2SE [52B/55B]
J082	4822 321 22611	RCA CONNECTIVE CORD (GOLD)
J083	4822 265 10092	JACK, AC ADAPTER [21B/21G]
J909	4822 401 11351	CLAMPER, SNAP PLATE
T100	4822 218 10427	IR COMMANDER

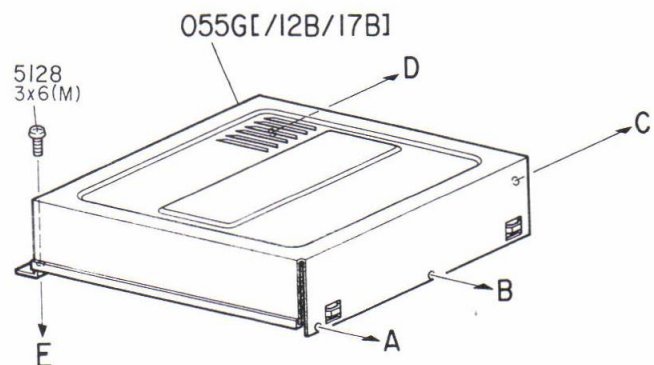
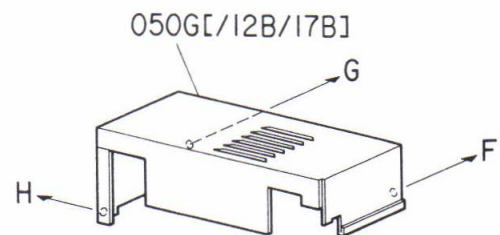

BLOCK DIAGRAM

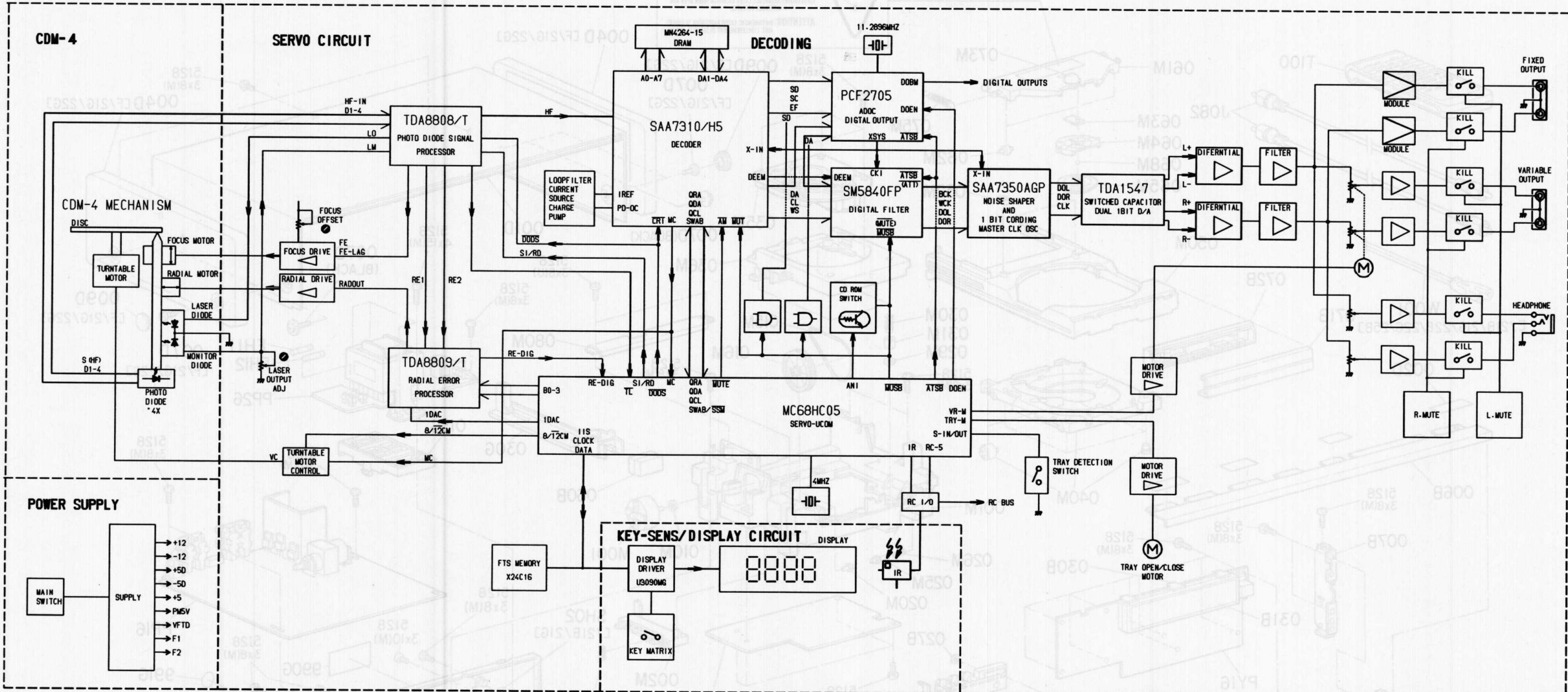

AGC-----AUTOMATIC GAIN CONTROL
 B0-B3-----CONTROL BITS FOR RADIAL CIRCUIT
 BEQ-----EQUALIZER REFERENCE CURRENT INPUT
 BGC-----DC AND LF GAIN CONTROL REFERENCE INPUT
 COSC1-----CAPACITOR WOBBLE OSCILLATOR
 COSC2-----CAPACITOR WOBBLE OSCILLATOR
 DEC-----DECOUPLING INPUT INTERNAL BYPASS
 DET-----HF DETECTOR VOLTAGE INPUT
 DIV4-----DIVIDE BY 4 INPUT
 DODS-----DROP OUT DETECTOR SUPPRESSION
 D1-4-----PHOTODIODE CURRENTS
 FE-----FOCUS ERROR SIGNAL
 FE LAG-----FOCUS ERROR SIGNAL FOR LAG NETWORK
 HF-----HF OUTPUT FOR DEMOD
 HF IN-----HF CURRENT INPUT TO HF AMPLIFIER
 HF OUT-----HF AMPLIFIER AND EQUALIZER VOLTAGE OUTPUT
 LM-----LASER MONITOR DIODE INPUT
 LO-----LASER AMPLIFIER CURRENT OUTPUT

MC-----MONITOR CONTROL SIGNAL
 OFFSET IN--OFFSET CONTROL INPUT
 OFFSET OUT--OFFSET CONTROL OUTPUT
 PLLH-----PLL ON HOLD OUTPUT
 RADOUT-----OUTPUT OF RE2-RE1 INPUT
 ROSC-----RESISTOR WOBBLE OSCILLATOR
 RWOB-----WOBBLE GENERATOR INPUT
 RE1-----RADIAL ERROR SIGNAL 1
 RE2-----RADIAL ERROR SIGNAL 2
 RE DIG-----RADIAL ERROR DIGITAL
 RE LAG-----RADIAL ERROR SIGNAL FOR LAG NETWORK
 SC-----STARTING UP CAPACITOR INPUT
 SI/RD-----ON/OFF CONTROL FOR LASER SUPPLY AND FOCUS
 TL-----TRACK LOSS OUTPUT SIGNAL
 VC-----CONTROL VOLTAGE FOR TURNTABLE MOTOR
 VEXT+ ---SUPPLY CONNECTION
 VEXT- ---SUPPLY CONNECTION

8/12CM---BAND WIDTH SWITCH 8 OR 12CM DISC
 ANI-----DIGITAL DATA INFORMATION ON DISC SIGNAL
 AM-----ADDITIONAL MUTE
 ATSB-----ATTENUATION OF AUDIO LEVEL IN SEARCH POSITION
 CL-----CLOCK SIGNAL DECODER TO FILTER
 BCK-----CLOCK SIGNAL FILTER TO DAC
 CREF-----REFERENCE CURRENT
 CRI-----COUNTER RESET INHIBIT
 1DAC-----ANTI SKATING CONTROL
 DA-----DATA SIGNAL DECODER TO FILTER
 DEEM-----DEEMPHASIS
 DOBM-----DIGITAL AUDIO OUT: BIPHASE MODULATED SIGNAL
 DOEM-----DIGITAL OUTPUT ENABLE
 DOL-----IIS SERIAL DATA (20BIT) L CHANNEL
 DOR-----IIS SERIAL DATA (20BIT) R CHANNEL

EF-----ERROR FLAG DECODER TO ADOC
 MUTE-----MUTE SIGNAL
 MUSB-----SOFT MUTE SIGNAL
 PD/OC-----PHASE DETECTOR-OSCILLATOR CONTROL
 QCL-----Q-CHANNEL CLOCK SIGNAL
 QDA-----Q-CHANNEL DATA SIGNAL
 QRA-----Q-CHANNEL REQUEST ACKNOWLEDGE
 SC-----SUBCODE CLOCK DECODER TO ADOC
 SD-----SUBCODE DATA DECODER TO ADOC
 SWAB/SSM--SUBCODE WORD/START-STOP MOTOR SIGNAL
 TRY-M ---TRAY MOTOR CONTROL
 VR-M-----VOLUME MOTOR CONTROL
 WS-----WORD SELECT DECODER TO FILTER
 WCK-----WORD SELECT FILTER TO DAC
 XIN-----OSCILLATOR SIGNAL IN
 XSYS-----OSCILLATOR SIGNAL OUT

SCHEMATIC DIAGRAM AND PARTS LOCATION (PATTERN SIDE)

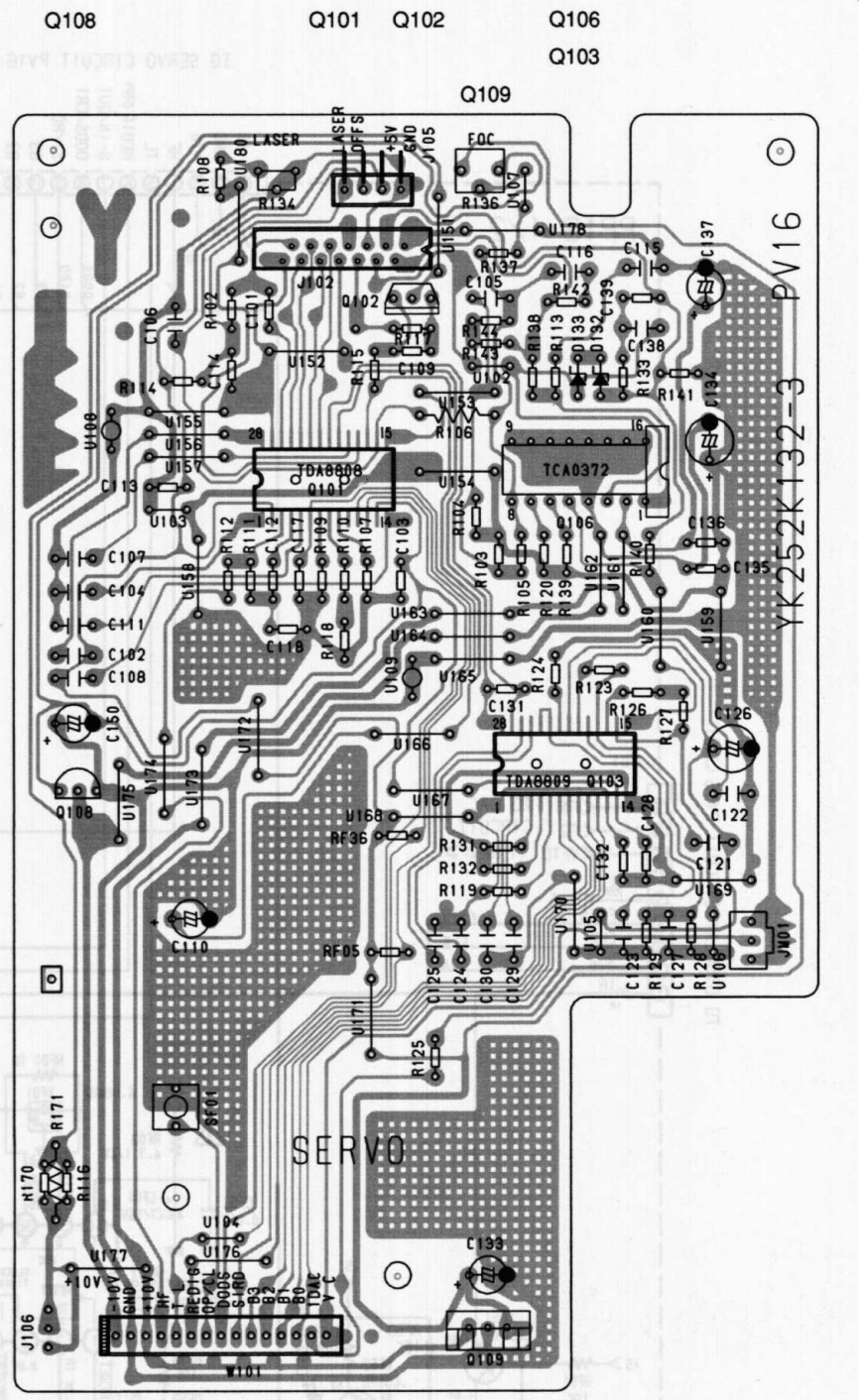
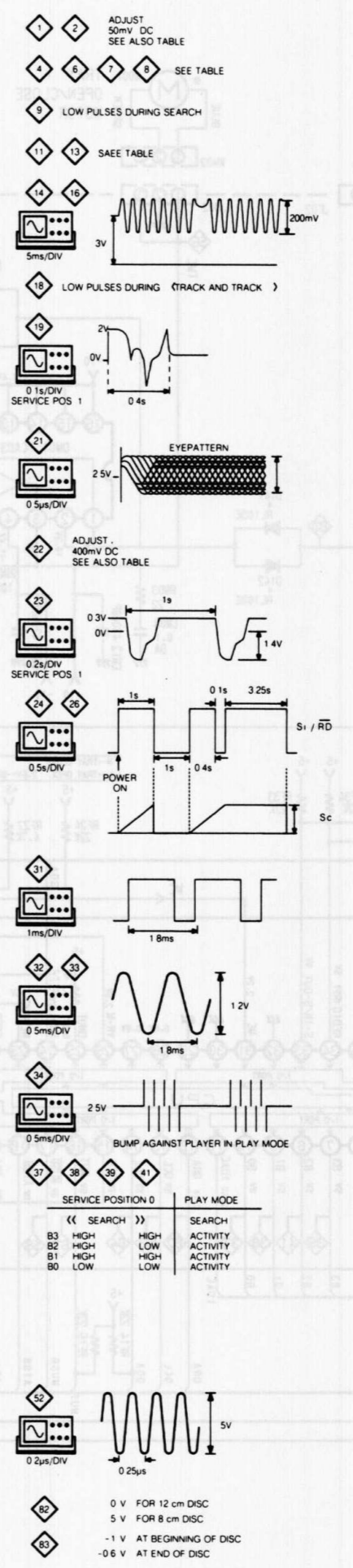
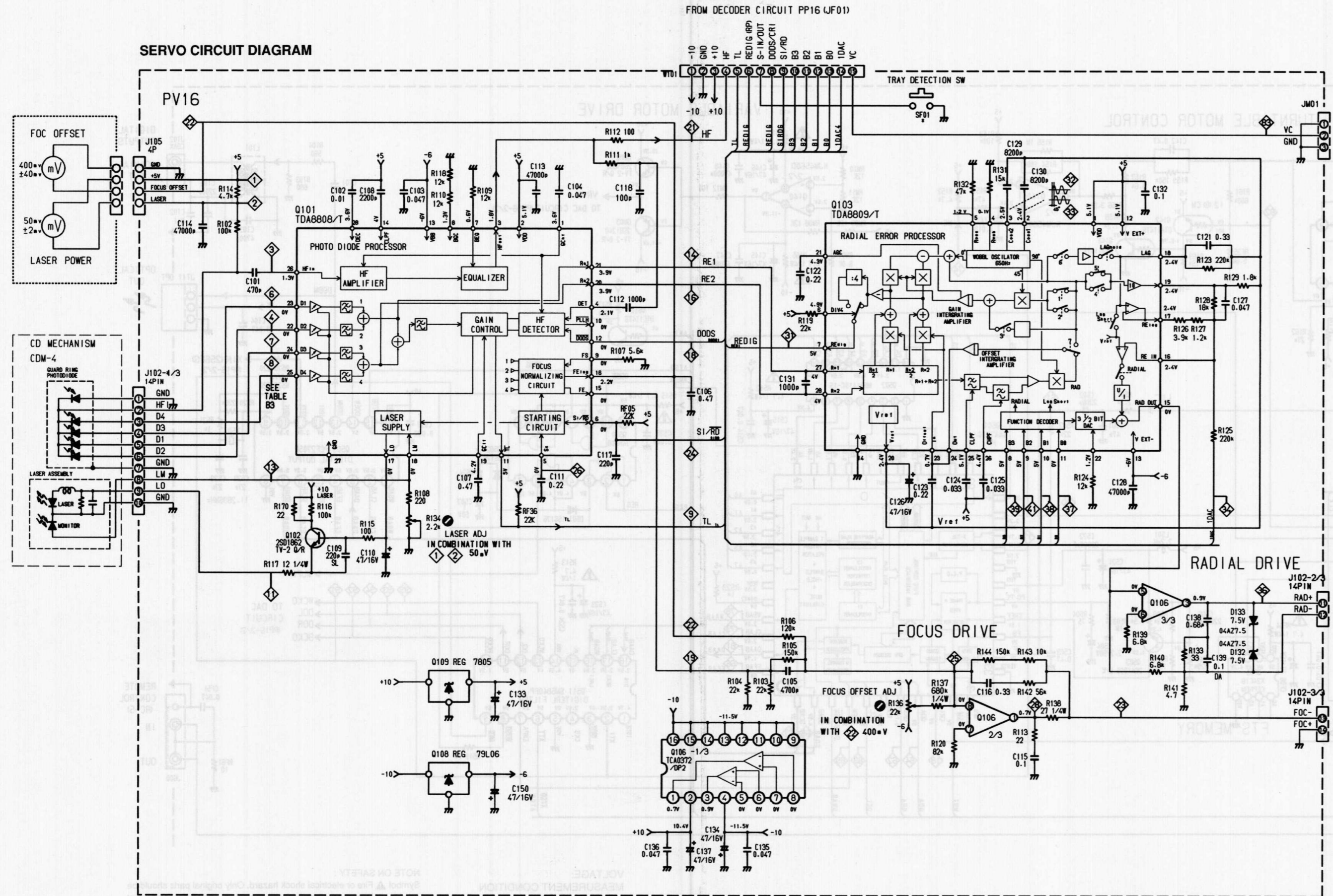

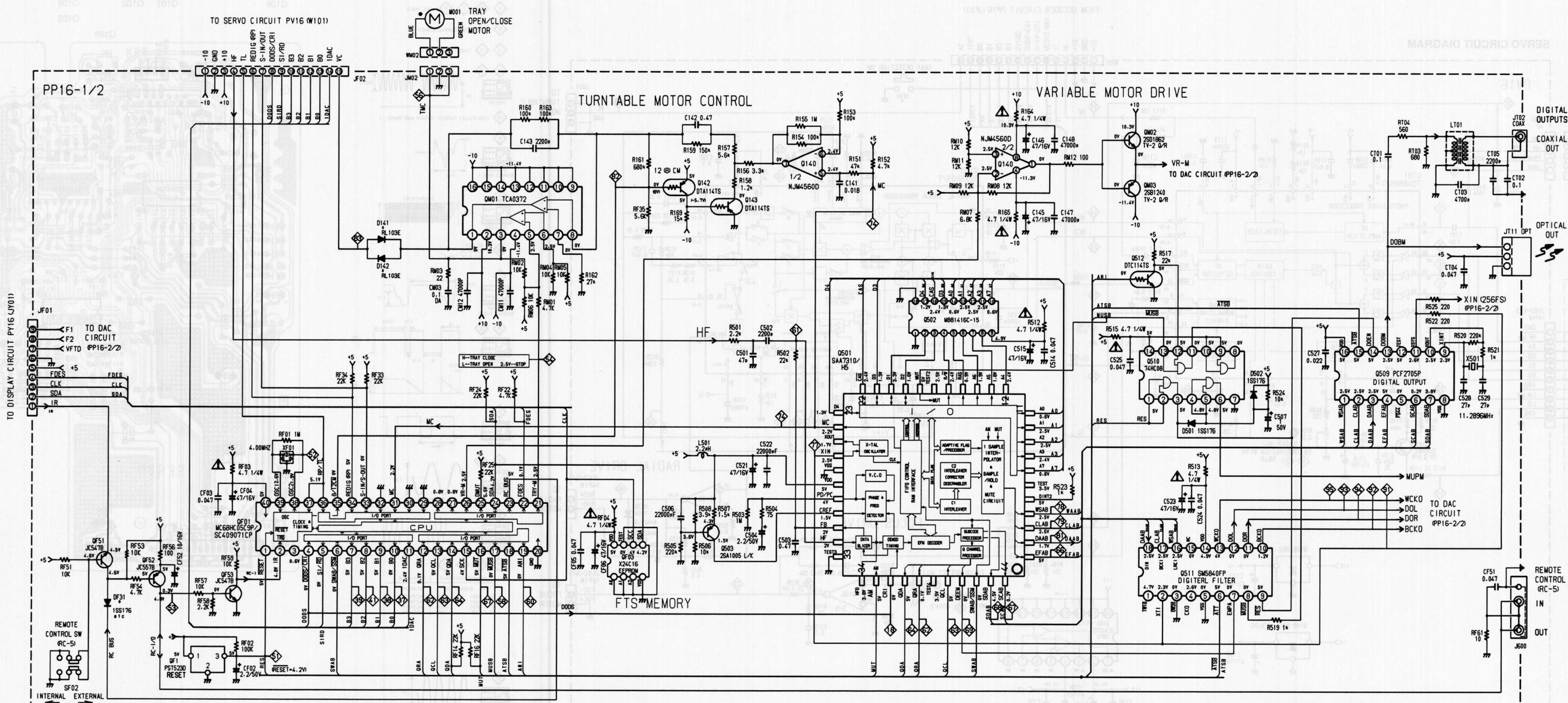

VOLTAGE:
MEASUREMENT CONDITION
DISC : 5A
MODE : STOP (TOC)

NOTE ON SAFETY :
Symbol ⚠ Fire or electrical shock hazard. Only original parts should be used to replace any part marked with symbol ⚠. Any other component substitution (other than original type), may increase risk of fire or electrical shock hazard.

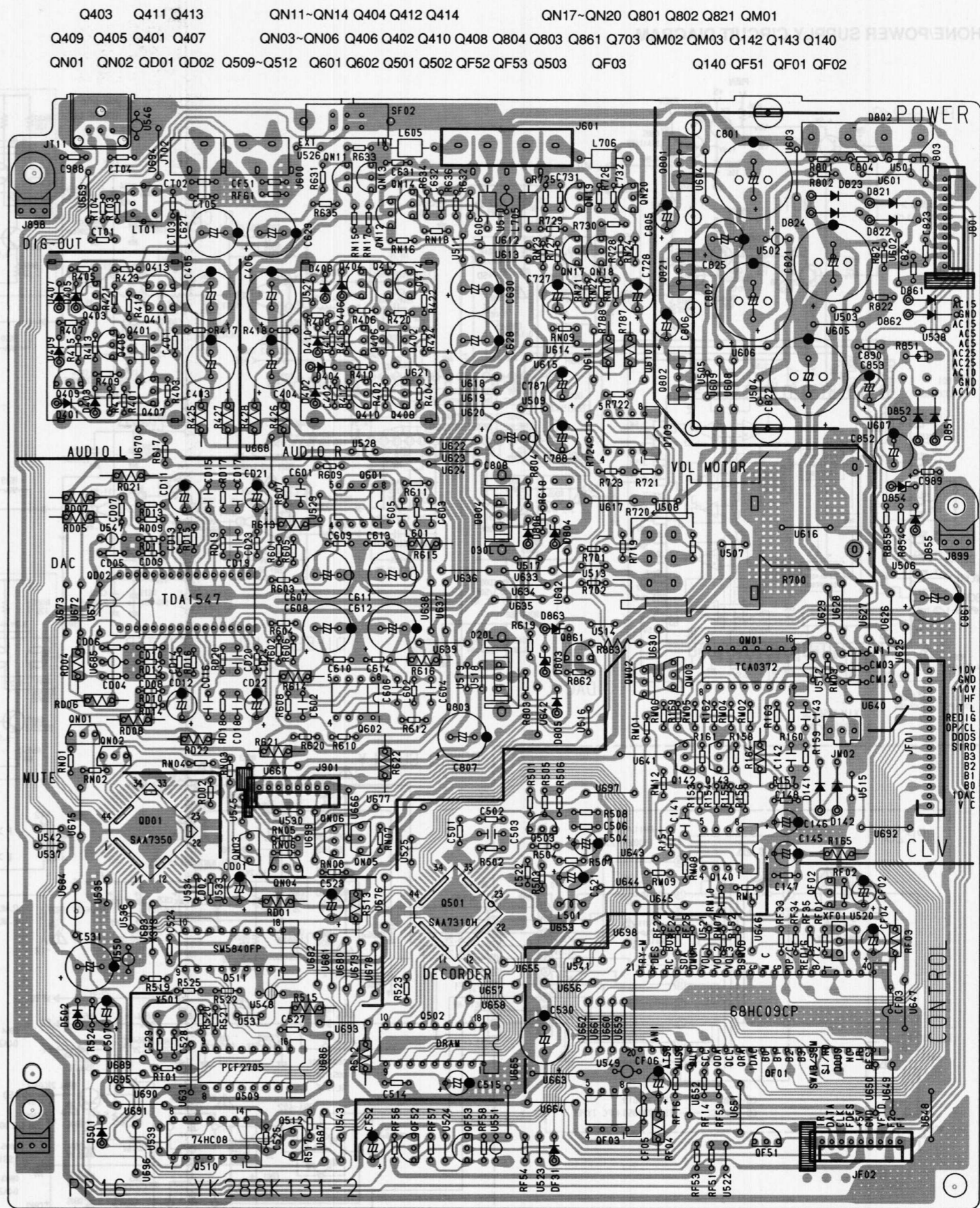
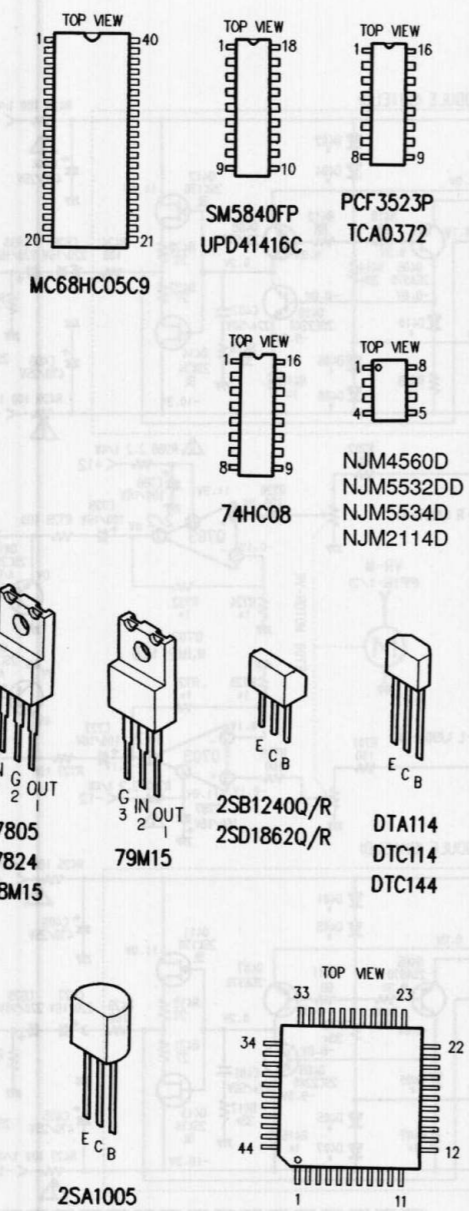
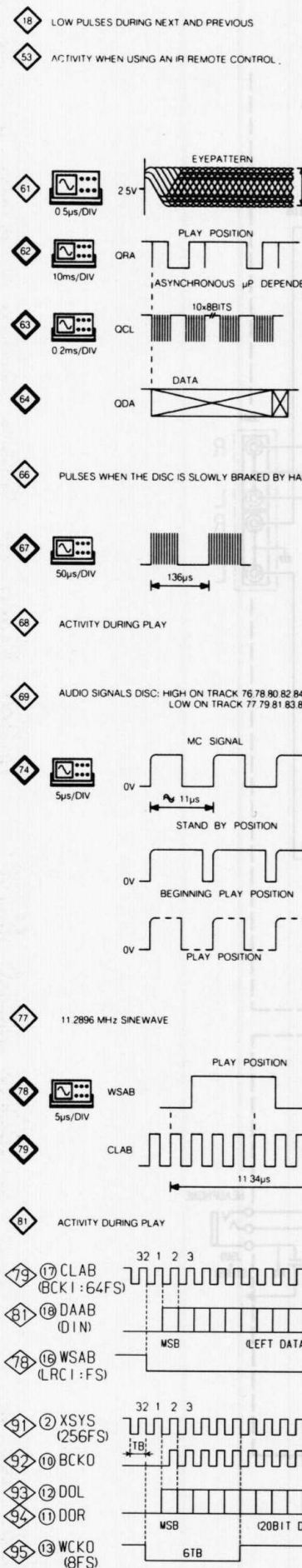

DAC/HEADPHONE/POWER SUPPLY CIRCUIT DIAGRAM

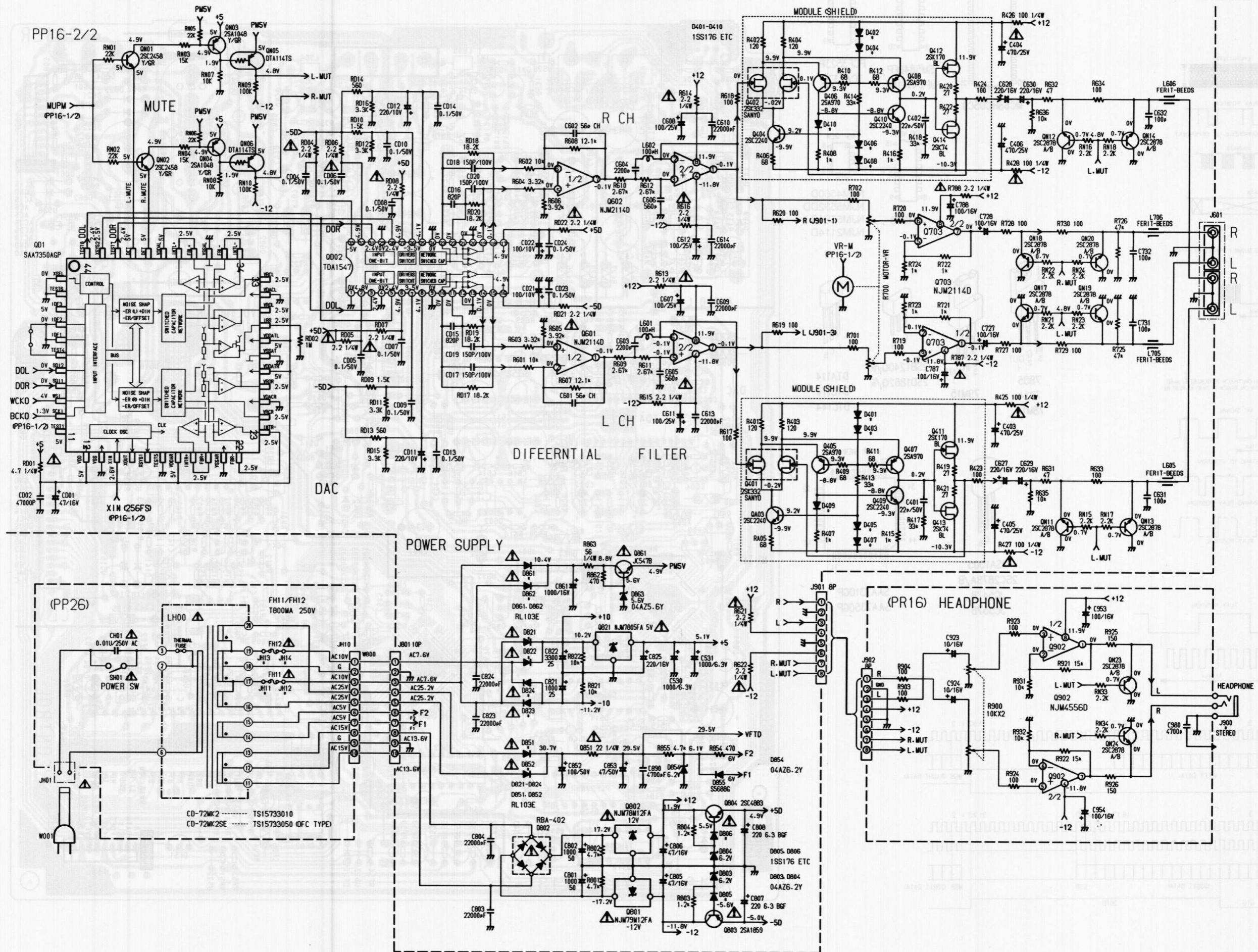

Q403 Q411 Q413 QN11-QN14 Q404 Q412 Q414 QN17-QN20 Q801 Q802 Q821 QM01
 Q409 Q405 Q401 Q407 QN03-QN06 Q406 Q402 Q410 Q408 Q804 Q803 Q861 Q703 QM02 QM03 Q142 Q143 Q140
 QN01 QN02 QD01 QD02 Q509-Q512 Q601 Q602 Q501 Q502 QF52 QF53 Q503 QF03 Q140 QF51 QF01 QF02

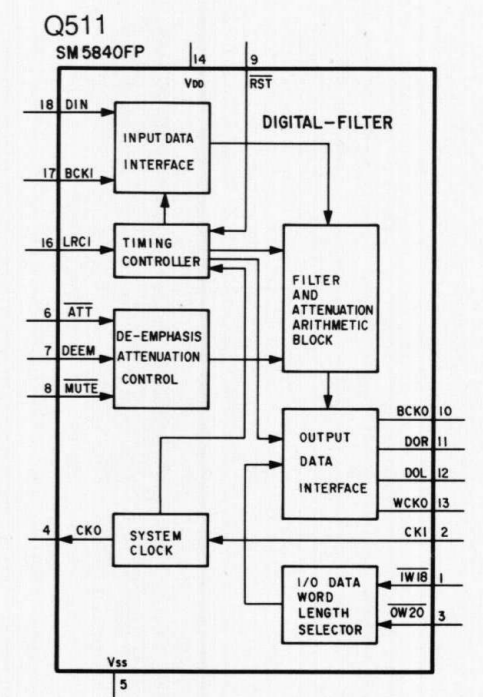
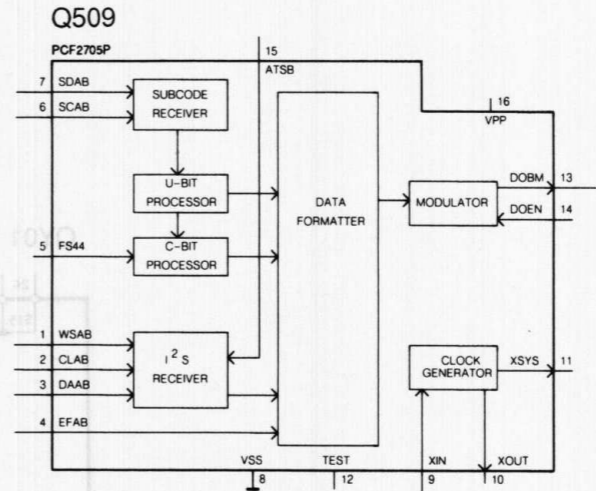
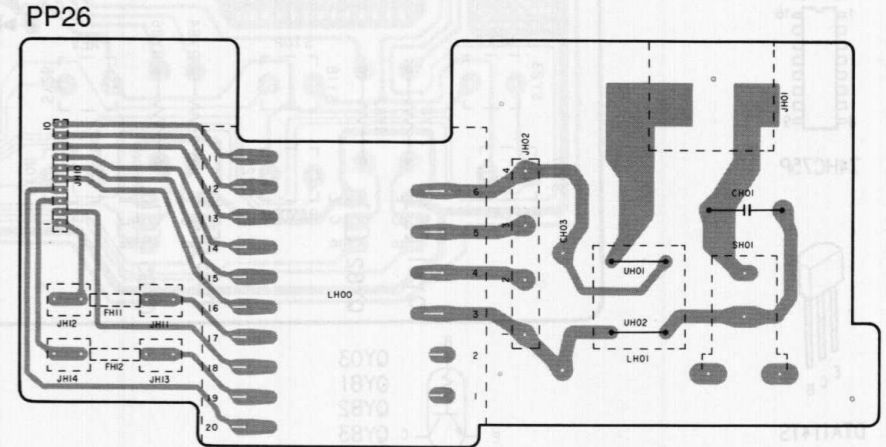
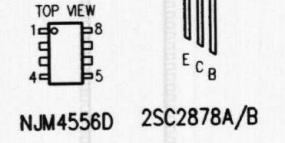
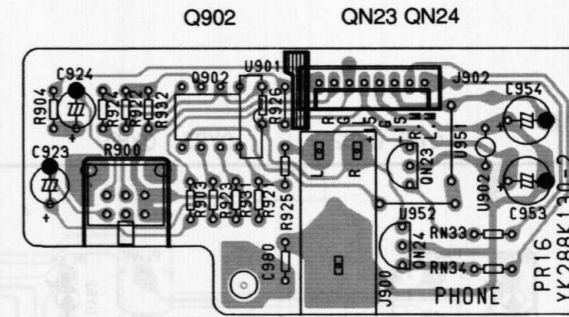
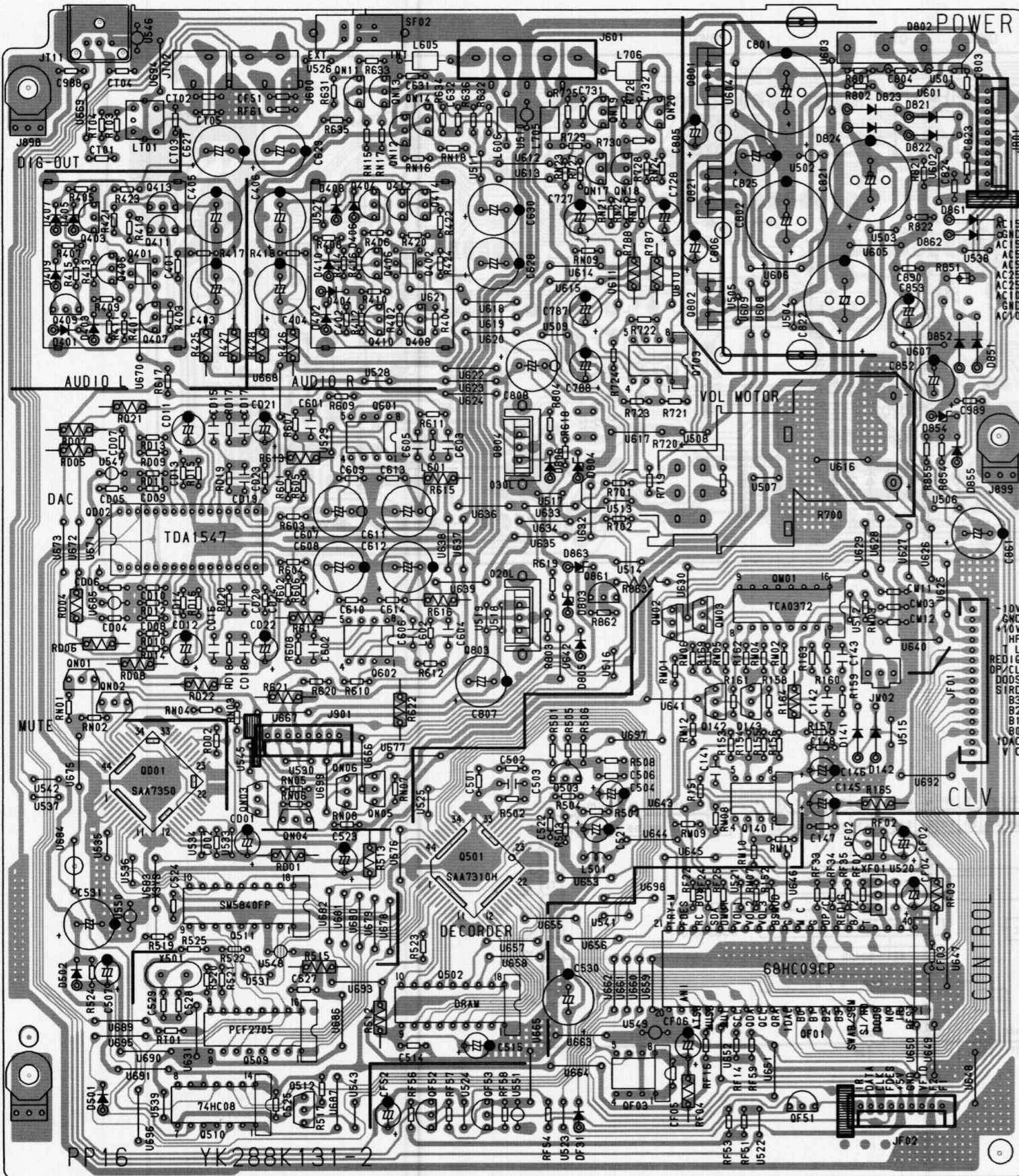

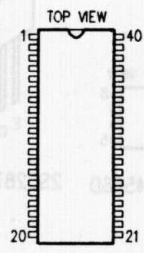

U3090MG

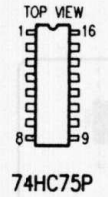

74HC75P



DTA114TS

PY16

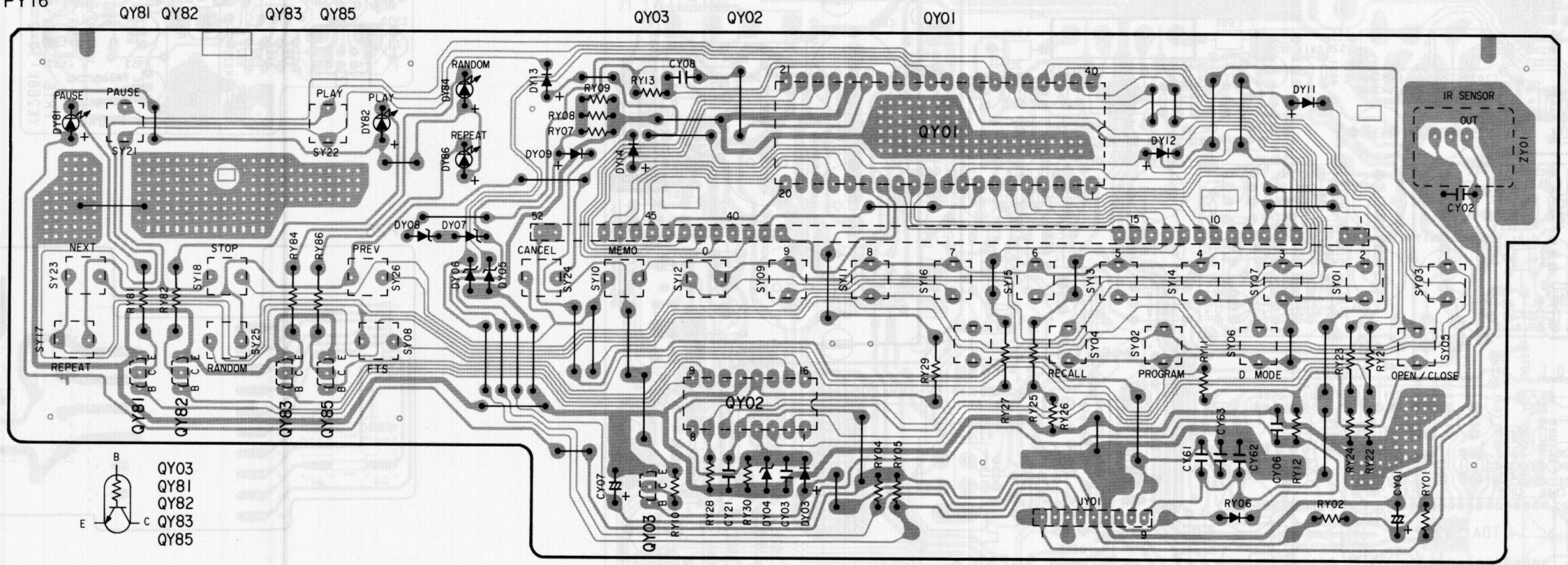

QY01

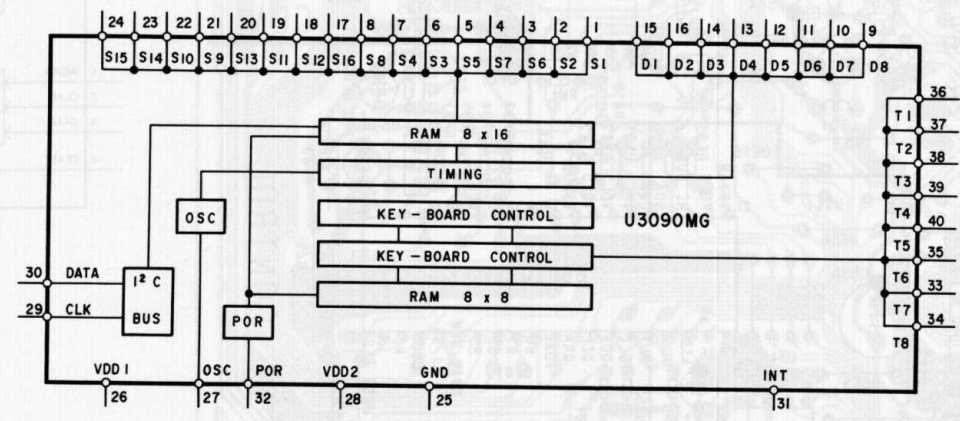

WIRING DIAGRAM

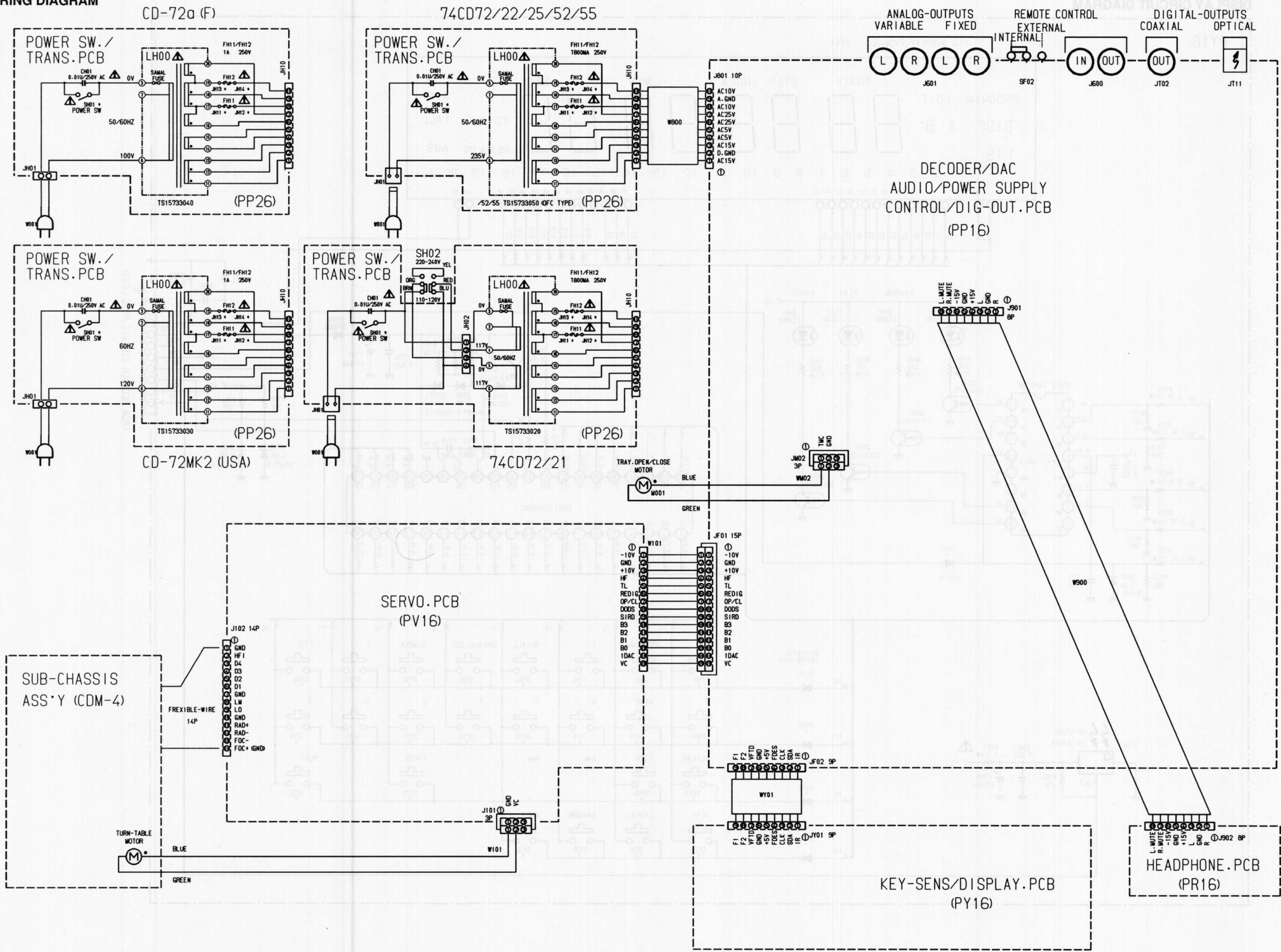

ELECTRICAL PARTS LIST

ASSIGNMENT OF COMMON PARTS CODES.

RESISTOR

R * * * : (1) GD05 xxx 140, Carbon film fixed resistor, $\pm 5\%$ 1/4W
R * * * : (2) GD05 xxx 160, Carbon film fixed resistor, $\pm 5\%$ 1/6W

① — Resistance value

Examples ;

① Resistance value

0.1 Ω001	10 Ω100	1 k Ω102	100 k Ω104
0.5 Ω005	18 Ω180	2.7 k Ω272	680 k Ω684
1 Ω010	100 Ω101	10 k Ω103	1 M Ω105
6.8 Ω068	390 Ω391	22 k Ω223	4.7 M Ω475

(Note) Please distinguish 1/4W from 1/6W by the shape of parts used actually.

C * * * : CERAMIC CAP.

(1) DD1x xxx 370, Ceramic capacitor
 Disc type
 Temp. coeff. P350 ~ N1000, 50V

① ②
 Capacity value
 Tolerance

Examples ;

① Tolerance (Capacity deviation)

$\pm 0.25\text{pF}$ 0
 $\pm 0.5\text{pF}$ 1
 $\pm 5\%$ 5

* Tolerance of COMMON PARTS handled here are as follows :

0.5pF ~ 5pF $\pm 0.25\text{pF}$
 6pF ~ 10pF $\pm 0.5\text{pF}$
 12pF ~ 560pF $\pm 5\%$

② Capacity value

0.5 pF005	3 pF030	100 pF101
1 pF010	10 pF100	220 pF221
1.5 pF015	47 pF470	560 pF561

C * * * : CERAMIC CAP.

(1) DK16 xxx 300, High dielectric constant ceramic capacitor
 Disc type
 Temp. chara. 2B4, 50V

① Capacity value

Examples ;

② Capacity value

100 pF101	1000 pF102	10000 pF103
470 pF471	2200 pF222	

C * * * : ELECTROLY CAP. ($\frac{\text{---}}{\text{---}}$), FILM CAP. ($\frac{\text{---}}{\text{---}}$)

(1) EA xxx xxx 10, Electrolytic capacitor
 One-way lead type,
 Tolerance $\pm 20\%$

① ②
 Working voltage
 Capacity value

Examples ;

① Capacity value

0.1 μF104	4.7 μF475	100 μF107
0.33 μF334	10 μF106	330 μF337
1 μF105	22 μF226	1100 μF118
		2200 μF228

② Working voltage

6.3 V006	25 V025
10 V010	35 V035
16 V016	50 V050

(2) DF15 xxx 350, Plastic film capacitor
 One-way type, Mylar $\pm 5\%$ 50V

① Capacity value

Examples ;

① Capacity value

0.001 μF (1000pF)102	0.1 μF104
0.0018 μF182	0.56 μF564
0.01 μF103	1 μF105
0.015 μF153	

NOTE : The above CODES (**R * * ***, **R * * ***, **C * * ***, **C * * *** and **C * * ***) are omitted on the schematic diagram in some case.

On the occasion, be confirmed common parts on the parts list.

REF. DESIG.	PART NO.	DESCRIPTION
		PP16-AUDIO/POWER CIRCUIT BOAARD
		PP16-CAPACITORS
CD01	4822 124 41539	ELECT 47 μF 16V
CD02	4822 122 40589	CERAMIC 0.047 μF +80%-20% 50V
CD04		
§	4822 126 11558	CERAMIC 0.1 μF +80%-20% 50V
CD10		
CD11	4822 124 90363	ELECT 220 μF 10V
CD12	4822 124 90363	ELECT 220 μF 10V
CD13	4822 126 11558	CERAMIC 0.1 μF +80%-20% 50V
CD14	4822 126 11558	CERAMIC 0.1 μF +80%-20% 50V
CD15	4822 121 70089	FILM 820PF $\pm 5\%$ 50V
CD16	4822 121 70089	FILM 820PF $\pm 5\%$ 50V
CD17		
§	4822 122 10367	CERAMIC 150PF $\pm 5\%$ 50V
CD20		
CD21	4822 124 90353	ELECT 100 μF 10V
CD22	4822 124 90353	ELECT 100 μF 10V
CD23	4822 126 11558	CERAMIC 0.1 μF +80%-20% 50V
CD24	4822 126 11558	CERAMIC 0.1 μF +80%-20% 50V
CF02	4822 124 90357	ELECT 2.2 μF 50V
CF03	4822 122 40589	CERAMIC 0.047 μF +80%-20% 50V
CF04	4822 124 41539	ELECT 47 μF 16V
CF05	4822 122 40589	CERAMIC 0.047 μF +80%-20% 50V
CF06	4822 124 41539	ELECT 47 μF 16V
CF51	4822 122 40589	CERAMIC 0.047 μF +80%-20% 50V
CF52	4822 124 90352	ELECT 10 μF 16V
CM03		CERAMIC 0.1 μF +80%-20% 50V
CM11	4822 122 40589	CERAMIC 0.047 μF +80%-20% 50V
CM12	4822 122 40589	CERAMIC 0.047 μF +80%-20% 50V
CT01	4822 126 11558	CERAMIC 0.1 μF +80%-20% 50V
CT02	4822 126 11558	CERAMIC 0.1 μF +80%-20% 50V
CT03	4822 122 33795	CERAMIC 4700PF +80%-20%
CT04	4822 122 40589	CERAMIC 0.047 μF +80%-20% 50V
CT05	4822 126 11726	CERAMIC 2200PF +80%-20%
C145	4822 124 41539	ELECT 47 μF 16V
C146	4822 124 41539	ELECT 47 μF 16V
C147	4822 122 40589	CERAMIC 0.047 μF +80%-20% 50V
C148	4822 122 40589	CERAMIC 0.047 μF +80%-20% 50V
C401	4822 126 10362	CERAMIC 22PF $\pm 5\%$
C402	4822 126 10362	CERAMIC 22PF $\pm 5\%$
C403		
§	4822 124 23649	ELECT 470 μF 25V
C406		
C501	4822 126 10513	CERAMIC 47PF $\pm 5\%$ 50V
C502	4822 126 11726	CERAMIC 2200PF +80%-20%
C503		FILM 0.47 μF 50V
C504	4822 124 90357	ELECT 2.2 μF 50V
C506	4822 122 40588	CERAMIC 0.022 μF $\pm 20\%$
C507	4822 124 41543	ELECT 1 μF 50V
C514	4822 122 40589	CERAMIC 0.047 μF +80%-20% 50V
C515	4822 124 41539	ELECT 47 μF 16V
C521	4822 124 41539	ELECT 47 μF 16V
C522	4822 122 40588	CERAMIC 0.022 μF $\pm 20\%$
C523	4822 124 41539	ELECT 47 μF 16V
C524	4822 122 40589	CERAMIC 0.047 μF +80%-20% 50V
C525	4822 122 40589	CERAMIC 0.047 μF +80%-20% 50V
C527	4822 122 40588	CERAMIC 0.022 μF $\pm 20\%$
C528	4822 122 33638	CERAMIC 27PF $\pm 5\%$
C529	4822 122 33638	CERAMIC 27PF $\pm 5\%$
C530	4822 124 22694	ELECT 1000 μF 6.3V
C531	4822 124 22694	ELECT 1000 μF 6.3V
C601	4822 122 32027	CERAMIC 56PF $\pm 5\%$ 50V
C602	4822 122 32027	CERAMIC 56PF $\pm 5\%$ 50V
C605	5322 122 32336	FILM 560PF $\pm 5\%$ 50V

REF. DESIG.	PART NO.	DESCRIPTION	REF. DESIG.	PART NO.	DESCRIPTION
C606	5322 122 32336	FILM 560PF \pm 5% 50V	R164	4822 111 90967	4.7 Ω \pm 5% 1/4W FUSE
C607	4822 124 22238	ELECT 100 μ F 25V	R165	4822 111 90967	4.7 Ω \pm 5% 1/4W FUSE
C608	4822 124 22238	ELECT 100 μ F 25V	R425		
C609	4822 122 40588	CERAMIC 0.022 μ F \pm 20%	§	4822 050 21021	100 Ω \pm 5% 1/4W
C610	4822 122 40588	CERAMIC 0.022 μ F \pm 20%	R428		
C611	4822 124 22238	ELECT 100 μ F 25V	R504	4822 111 41355	75 Ω \pm 5% 1/6W
C612	4822 124 22238	ELECT 100 μ F 25V	R512	4822 111 90967	4.7 Ω \pm 5% 1/4W FUSE
C613	4822 122 40588	CERAMIC 0.022 μ F \pm 20%	R513	4822 111 90967	4.7 Ω \pm 5% 1/4W FUSE
C614	4822 122 40588	CERAMIC 0.022 μ F \pm 20%	R515	4822 111 90967	4.7 Ω \pm 5% 1/4W FUSE
C627	4822 124 22039	ELECT 220 μ F 16V [21B/22B/25B/21G/22G]	R601	4822 116 82752	10K Ω \pm 1% 1/6W
C627	4822 124 80123	ELECT 220 μ F 16V [52B/55B]	R602	4822 116 82752	10K Ω \pm 1% 1/6W
C628	4822 124 22039	ELECT 220 μ F 16V [21B/22B/25B/21G/22G]	R603	4822 117 10439	3.32K Ω \pm 1% 1/6W
C628	4822 124 80123	ELECT 220 μ F 16V [52B/55B]	R604	4822 117 10439	3.32K Ω \pm 1% 1/6W
C629	4822 124 22039	ELECT 220 μ F 16V [21B/22B/25B/21G/22G]	R605	4822 117 10441	3.92K Ω \pm 1% 1/6W
C629	4822 124 80123	ELECT 220 μ F 16V [52B/55B]	R606	4822 117 10441	3.92K Ω \pm 1% 1/6W
C630	4822 124 22039	ELECT 220 μ F 16V [21B/22B/25B/21G/22G]	R607	4822 116 82753	12.1K Ω \pm 1% 1/6W
C630	4822 124 80123	ELECT 220 μ F 16V [52B/55B]	R608	4822 116 82753	12.1K Ω \pm 1% 1/6W
C631	4822 126 10364	CERAMIC 100PF \pm 10%	R609		
C632	4822 126 10364	CERAMIC 100PF \pm 10%	§	4822 117 10449	2.67K Ω \pm 1% 1/6W
C727	4822 124 90354	ELECT 100 μ F 16V	R612		
C728	4822 124 90354	ELECT 100 μ F 16V	R613		
C731	4822 126 10364	CERAMIC 100PF \pm 10%	§	4822 116 83963	2.2 Ω \pm 5% 1/4W
C732	4822 126 10364	CERAMIC 100PF \pm 10%	R616		
C787	4822 124 90354	ELECT 100 μ F 16V	R621	4822 116 83963	2.2 Ω \pm 5% 1/4W
C788	4822 124 90354	ELECT 100 μ F 16V	R622	4822 116 83963	2.2 Ω \pm 5% 1/4W
C801	4822 124 23918	ELECT 1000 μ F 50V [21B/22B/25B/21G/22G]	R700	4822 101 30763	10K Ω x 2 B VARIABLE
C801	4822 124 80257	ELECT 1000 μ F 35V [52B/55B]	R787	4822 116 83963	2.2 Ω \pm 5% 1/4W
C802	4822 124 23918	ELECT 1000 μ F 50V [21B/22B/25B/21G/22G]	R788	4822 116 83963	2.2 Ω \pm 5% 1/4W
C802	4822 124 80257	ELECT 1000 μ F 35V [52B/55B]			
C803	4822 122 40588	CERAMIC 0.022 μ F \pm 20%			
C804	4822 122 40588	CERAMIC 0.022 μ F \pm 20%			
C805	4822 124 41539	ELECT 47 μ F 16V			
C806	4822 124 41539	ELECT 47 μ F 16V			
C807	4822 124 23363	ELECT 220 μ F 6.3V			
C808	4822 124 23363	ELECT 220 μ F 6.3V			
C821	4822 124 23918	ELECT 1000 μ F 50V			
C822	4822 124 22239	ELECT 3300 μ F 25V			
C823	4822 122 40588	CERAMIC 0.022 μ F \pm 20%			
C824	4822 122 40588	CERAMIC 0.022 μ F \pm 20%			
C825	4822 124 90364	ELECT 220 μ F 16V			
C852	4822 124 90355	ELECT 100 μ F 50V			
C853	4822 124 22276	ELECT 47 μ F 50V			
C861	4822 124 22722	ELECT 1000 μ F 16V			
C890	4822 122 33795	CERAMIC 4700PF +80%-20%			
C980	4822 122 33795	CERAMIC 4700PF +80%-20%			
C***		PP16-CAPACITORS (COMMON) Plastic film capacitor One-way type, Mylar \pm 5% 50V C141~C143, C503, C603, C604			
Q851	4822 116 60318	PP16-RESISTORS 2.2 Ω \pm 5% 1/4W			
RD01	4822 111 90967	4.7 Ω \pm 5% 1/4W FUSE			
RD04					
§	4822 116 83963	2.2 Ω \pm 5% 1/4W			
RD08					
RD17					
§	4822 117 10448	18.2K Ω \pm 1% 1/6W			
RD20					
RD21	4822 116 83963	2.2 Ω \pm 5% 1/4W			
RD22	4822 116 83963	2.2 Ω \pm 5% 1/4W			
RF03	4822 111 90967	4.7 Ω \pm 5% 1/4W FUSE			
RF04	4822 111 90967	4.7 Ω \pm 5% 1/4W FUSE			
					PP16-RESISTORS (COMMON) CARBON FILM FIXED RESISTOR, \pm 5% 1/4W: U631
					PP16-SEMICONDUCTORS
					DIODE, 1SS176,MA165,1SS254 30V 0.1A
					DIODE, RL103E, DSF10C
					DIODE, RL103E, DSF10C
					DIODE, 1SS176,MA165,1SS254 30V 0.1A
					DIODE, 1SS176,MA165,1SS254 30V 0.1A
					DIODE, 1SS176,MA165,1SS254 30V 0.1A
					DIODE, RBA-402 BRIDGE
					ZENER DIODE, 04AZ6.2-Y 6.2V
					ZENER DIODE, 04AZ6.2-Y 6.2V
					DIODE, 1SS176,MA165,1SS254 30V 0.1A
					DIODE, 1SS176,MA165,1SS254 30V 0.1A
					DIODE, RL103E, DSF10C
					DIODE, RL103E, DSF10C
					ZENER DIODE, 04AZ6.2-Y 6.2V

REF. DESIG.	PART NO.	DESCRIPTION
D854	4822 130 80932	ZENER DIODE, 04AZ6.2-Y 6.2V
D855	4822 130 80839	DIODE, S5688G 1A 400V
D861	4822 130 32508	DIODE, RL103E, DSF10C
D862	4822 130 32508	DIODE, RL103E, DSF10C
D863	4822 130 33948	ZENER DIODE, 04AZ5.6-Y 5.6V
QD01	4822 209 31356	IC, BS DAC SAA7350 AGP
QD02	4822 209 31013	IC, TDA1547
QF01	4822 209 32172	MICROPROCESSOR, MC68HC05C9 MAIN μ -COM
QF02	4822 209 73951	IC, RESET PST523D
QF03	4822 209 52171	IC, EEPROM X24C16
QF51	4822 130 62295	TRANSISTOR, JC547B
QF52	4822 130 62386	TRANSISTOR, JC557B
QF53	4822 130 62295	TRANSISTOR, JC547B
QM01	4822 209 62755	IC, POWER OP AMP TCA0372
QM02	4822 130 61441	TRANSISTOR, 2SD1862 (Q,R)
QM03	4822 130 61417	TRANSISTOR, 2SB1240 (Q,R)
QN01	4822 130 60839	TRANSISTOR, 2SC2458 (Y, GR)
QN02	4822 130 60839	TRANSISTOR, 2SC2458 (Y, GR)
QN03	4822 130 60107	TRANSISTOR, 2SA1048 (Y, GR)
QN04	4822 130 60107	TRANSISTOR, 2SA1048 (Y, GR)
QN05	4822 130 63211	DIGITAL TRANSISTOR, DTA114TS
QN06	4822 130 63211	DIGITAL TRANSISTOR, DTA114TS
QN11		
Q	4822 130 43819	TRANSISTOR, 2SC2878 (A, BRANK)
QN14		
Q	4822 130 43819	TRANSISTOR, 2SC2878 (A, BRANK)
QN17		
Q	4822 130 43819	TRANSISTOR, 2SC2878 (A, BRANK)
QN20		
Q140	4822 209 83627	IC, NJM4560D
Q142	4822 130 63211	DIGITAL TRANSISTOR, DTA114TS
Q143	4822 130 63211	DIGITAL TRANSISTOR, DTA114TS
Q401	4822 130 63382	F.E.T. 2SK332 D
Q402	4822 130 63382	F.E.T. 2SK332 D
Q403	4822 130 43233	TRANSISTOR, 2SC2240 (GR, BL)
Q404	4822 130 43233	TRANSISTOR, 2SC2240 (GR, BL)
Q405		
Q	4822 130 42951	TRANSISTOR, 2SA970 (GR, BL)
Q408		
Q409	4822 130 43233	TRANSISTOR, 2SC2240 (GR, BL)
Q410	4822 130 43233	TRANSISTOR, 2SC2240 (GR, BL)
Q411	5322 130 41844	F.E.T. 2SK170 BL
Q412	5322 130 41844	F.E.T. 2SK170 BL
Q413	4822 130 62649	F.E.T. 2SJ74 BL
Q414	4822 130 62649	F.E.T. 2SJ74 BL
Q501	4822 209 63453	IC, DEM/ERCO SAA7310 QFP
Q502	4822 209 73952	IC, D-RAM MB81416C-15 MN4264P-15
Q503	4822 130 61438	TRANSISTOR, 2SA1005 (L, K)
Q509	4822 209 62588	IC, PCF2705P
Q510	4822 209 63471	IC, AND GATE 74HC08
Q511	4822 209 30435	IC, DIGITAL FILTER SM5840FP
Q512	4822 130 61189	DIGITAL TRANSISTOR, DTC114TS
Q601	4822 209 31153	IC, NJM2114D
Q602	4822 209 31153	IC, NJM2114D
Q703	4822 209 31153	IC, NJM2114D
Q801	4822 209 63641	IC, NJM79M12FA
Q802	4822 209 31712	IC, NJM78M12FA
Q803	4822 130 63308	TRANSISTOR, 2SA1859 (O, Y)
Q804	4822 130 63312	TRANSISTOR, 2SC4883 (O, Y)
Q821	4822 209 31631	IC, NJM7805FA
Q861	4822 130 62295	TRANSISTOR, JC547B
		PP16-MISCELLANEOUS
JT02	4822 265 20354	TERMINAL, 1P RCA (GOLD) DIGITAL
JT11	4822 267 31369	JACK, GP1F32T OPTICAL OUTPUT
J600	4822 266 30274	TERMINAL, 2P RCA

REF. DESIG.	PART NO.	DESCRIPTION
J601	4822 266 30369	TERMINAL, 4P (GOLD) RCA AUDIO
LT01	4822 142 60388	PULSE TRANSFORMER
L501	4822 152 20647	CHOKE COIL, 2.2 μ H
L601	4822 157 62919	CHOKE COIL, 100 μ H
L602	4822 157 62919	CHOKE COIL, 100 μ H
L605	4822 158 60605	FERRITE CORE, BEADS
L606	4822 158 60605	FERRITE CORE, BEADS
L705	4822 158 60605	FERRITE CORE, BEADS
L706	4822 158 60605	FERRITE CORE, BEADS
SF02	4822 277 21559	SLIDE SWITCH, INT/EXT RC-5
XF01	4822 242 72223	CERAMIC VIBRATOR 4.00MHz CST4.00MGW
X501	4822 242 72395	CRYSTAL, 11.2896MHz
		PP26-POWER SW CIRCUIT BOARD
		PP26-CAPACITORS
CH01	4822 121 43732	FILM 0.01 μ F \pm 20% 250V [21B/22B/52B/21G/22G]
CH01	4822 122 33276	CERAMIC 0.01 μ F \pm 20% 400V [25B/55B]
		PP26-MISCELLANEOUS
FH11	4822 253 30402	FUSE, 800 MA 250V BS LISTED
FH12	4822 253 30402	FUSE, 800 MA 250V BS LISTED
JH01	4822 267 31416	JACK, AC INLET [21B/22B/25B/55B/21G/22G]
JH01	4822 267 31521	PLUG, AC INLET [52B]
JH11	4822 256 30329	JACK, FUSE HOLDER
JH12	4822 267 30978	JACK, FUSE HOLDER
JH13	4822 256 30329	JACK, FUSE HOLDER
JH14	4822 267 30978	JACK, FUSE HOLDER
LH00	4822 146 21742	POWER TRANSFORMER 230V [21B/22B/25B/21G/22G]
LH00	4822 146 21745	POWER TRANSFORMER 230V OFC [52B/55B]
SH01	4822 276 12925	PUSH SWITCH, POWER
		PR16-HEAD AMP CIRCUIT BOARD
		PR16-CAPACITORS
C923	4822 124 90352	ELECT 10 μ F 16V
C924	4822 124 90352	ELECT 10 μ F 16V
C953	4822 124 90354	ELECT 100 μ F 16V
C954	4822 124 90354	ELECT 100 μ F 16V
		PR16-RESISTORS
R900	4822 100 20421	10K Ω X2 (B) VARIABLE
		PR16-RESISTORS (COMMON)
		CARBON FILM FIXED RESISTOR, \pm 5% 1/6W: RN33, RN34, R903, R904, R921~R926, R931, R932
		PR16-SEMICONDUCTORS
QN23	4822 130 43819	TRANSISTOR, 2SC2878 (A, BRANK)
QN24	4822 130 43819	TRANSISTOR, 2SC2878 (A, BRANK)
Q902	4822 209 83654	IC, NJM4556D

REF. DESIG.	PART NO.	DESCRIPTION
		PV16-SERVO CIRCUIT BOARD
		PV16-CAPACITORS
C101	4822 126 11127	CERAMIC 470PF ± 10%
C103	4822 122 40589	CERAMIC 0.047µF +80%-20% 50V
C109	4822 126 10408	CERAMIC 220PF ± 10%
C110	4822 124 41539	ELECT 47µF 16V
C112	4822 122 33639	CERAMIC 1000PF ± 10%
C113	4822 122 40589	CERAMIC 0.047µF +80%-20% 50V
C114	4822 122 40589	CERAMIC 0.047µF +80%-20% 50V
C117	4822 126 10408	CERAMIC 220PF ± 10%
C118	4822 126 10364	CERAMIC 100PF ± 10%
C126	4822 124 23056	ELECT 47µF 16V
C128	4822 122 40589	CERAMIC 0.047µF +80%-20% 50V
C131	4822 122 33639	CERAMIC 1000PF ± 10%
C132		CERAMIC 0.1µF +80%-20% 50V
C133	4822 124 41539	ELECT 47µF 16V
C134	4822 124 23056	ELECT 47µF 16V
C135	4822 122 40589	CERAMIC 0.047µF +80%-20% 50V
C136	4822 122 40589	CERAMIC 0.047µF +80%-20% 50V
C137	4822 124 41539	ELECT 47µF 16V
C139		CERAMIC 0.1µF +80%-20% 50V
C150	4822 124 41539	ELECT 47µF 16V
		PV16-CAPACITORS (COMMON)
C***		Plastic film capacitor One-way type, Mylar ± 5% 50V C102, C104~C108, C111, C115, C116, C121~C125, C127, C129, C130, C138
		PV16-RESISTORS
R134	4822 101 30707	2.2K Ω TRIMMING LASER
R136	4822 100 20539	22K Ω TRIMMING FOC
		PV16-RESISTORS (COMMON)
R***		CARBON FILM FIXED RESISTOR, ± 5% 1/6W: R102~R120, R123~R129, R131~R133, R137~R144, R170, RF05, RF36
		PV16-SEMICONDUCTORS
D132	4822 130 80272	ZENER DIODE, 04AZ7.5-Z 7.5V
D133	4822 130 80272	ZENER DIODE, 04AZ7.5-Z 7.5V
Q101	4822 209 30436	IC,HF & FOC TDA8808 QFP
Q102	4822 130 61441	TRANSISTOR, 2SD1862 (Q,R)
Q103	4822 209 30437	IC, TDA8809 (RAD) QFP
Q106	4822 209 62755	IC, POWER OP AMP TCA0372
Q108	4822 209 30442	IC, NJM79L06A
Q109	4822 209 31631	IC, NJM7805FA
		PV16-MISCELLANEOUS
JM01	4822 265 30777	PLUG, 3P
J102	4822 267 50676	JACK, SUB CHASSIS CONNECTOR
SF01	4822 276 13296	PUSH SWITCH,, TRAY DETECTOR
		PY16-FRONT CIRCUIT BOARD
		PY16-CAPACITORS
CY01	4822 124 41539	ELECT 47µF 16V
CY02	4822 122 40588	CERAMIC 0.022µF ± 20%
CY03	4822 126 10408	CERAMIC 220PF ± 10%
CY06	4822 122 40588	CERAMIC 0.022µF ± 20%
CY07	4822 124 22276	ELECT 47µF 50V
CY08	4822 126 11127	CERAMIC 470PF ± 10%
CY21	4822 122 40588	CERAMIC 0.022µF ± 20%
CY61	4822 122 40588	CERAMIC 0.022µF ± 20%
CY62	4822 122 40589	CERAMIC 0.047µF +80%-20% 50V
CY63	4822 122 40589	CERAMIC 0.047µF +80%-20% 50V
		PY16-RESISTORS
RY02	4822 111 90967	4.7 Ω ± 5% 1/4W FUSE

REF. DESIG.	PART NO.	DESCRIPTION
		PY16-RESISTORS (COMMON)
R***		CARBON FILM FIXED RESISTOR, ± 5% 1/4W: RY21, RY23, RY25, RY27, RY29, RY81, RY82, RY84, RY86
R***		CARBON FILM FIXED RESISTOR, ± 5% 1/6W: RY01, RY04, RY05, RY07~RY13, RY22, RY24, RY26, RY28, RY30
		PY16-SEMICONDUCTORS
RY06	4822 130 80839	DIODE, S5688G VRM400V IO=1A
DY03	4822 130 33305	DIODE, 1SS176,MA165,1SS254 30V 0.1A
DY04	4822 130 33948	ZENER DIODE, 04AZ5.6-Y 5.6V
DY05	4822 130 33948	ZENER DIODE, 04AZ5.6-Y 5.6V
DY06	4822 130 33948	ZENER DIODE, 04AZ5.6-Y 5.6V
DY07	4822 130 80272	ZENER DIODE, 04AZ7.5-Z 7.5V
DY08	4822 130 80272	ZENER DIODE, 04AZ7.5-Z 7.5V
DY09	4822 130 33305	DIODE, 1SS176,MA165,1SS254 30V 0.1A
DY11		
§		
DY14	4822 130 33305	DIODE, 1SS176,MA165,1SS254 30V 0.1A
DY81	4822 130 80325	L.E.D. LT3H8B (YELLOW)
DY82	4822 130 82964	L.E.D. LT3G8B (GREEN)
DY84	4822 130 82964	L.E.D. LT3G8B (GREEN)
DY86	4822 130 82964	L.E.D. LT3G8B (GREEN)
QY01	4822 209 30434	IC, DISPLAY DRIVER U3090MG
QY02	4822 209 30443	IC, 4BIT D TYPE LATCH 74HC75AP
QY03	4822 130 61189	DIGITAL TRANSISTOR, DTC114TS
QY81		
§		
QY83	4822 130 61189	DIGITAL TRANSISTOR, DTC114TS
QY85	4822 130 61189	DIGITAL TRANSISTOR, DTC114TS
		PY16-MISCELLANEOUS
SY01		
§		
SY18	4822 276 20508	PUSH SWITCH
SY21		
§		
SY26	4822 276 20508	PUSH SWITCH
VY01	4822 130 91032	DISPLAY UNIT FV364G
ZY01	4822 130 82393	PHOTO UNIT IR-RECEIVER GP1U720R 36KHZ

NOTE ON SAFETY

Symbol ▲ Fire or electrical shock hazard. Only original parts should be used to replace any part marked with symbol ▲. Any other component substitution (other than original type), may increase risk of fire or electrical shock hazard.